



# 产品规格书

## PRODUCT SPECIFICATION

客户名称Buyer Name	
客户料号Buyer Part No.	
客户承认签章 Buyers Approval & Signatures	

文件编号Spec No.	HG2230-70S	版本	A/1
品名描述 Product Description	LRA 扁平振动马达 LRA Coin Vibration Motor		
型号Part No.	VG2230001H		
送样日期Date			
设计Designed by	审核Checked by	批准Approved by	
2022.04.22	2022.04.22	2022.04.22	

www.vybronic.com

sales@vybronic.com

**REVISED RECORD 修订记录**

Rev. No	Rev. Date	Page No.	Revised Item	Reason
A/0	2022.02.24	/	Preliminary Spec/初始规格	
A/1	2022.04.22	/	Update voltage operating parameters /更新电压工作参数	

**TABLE OF CONTENTS****目录表**

NO.	CONTE (内容)	PAGE (页码)	NOTE (备注)
1	Operating scope 适用范围	4	
2	Storage/Operating / Measure environmental conditions 使用和储存条件	4	
3	Measuring Conditions 测试条件	4	
4	Product performance 制品性能	5	
5	External performance 外观性能	6	
6	Reliability test 可靠性试验	7	
7	Outline drawing 外形图	8	
8	Encoding rules 编码规则	9	
9	Packaging requirements 包装要求	9	
10	Caution for Use 使用注意事项	9	

**1. Operating scope 适用范围**

This specifications apply to linear vibrator model VG2230001H.

本规格书适用于 VG2230001H 线性振动器。

**2. Storage, Operating temperature / Humidity conditions (储存、使用温度/湿度条件)**

No	Items (项目)	Conditions (条件)
2-5	Operating Environmental 使用环境	Temperature / 温度: $-30^{\circ}\text{C} \sim 70^{\circ}\text{C}$ Humidity / 湿度: $5 \sim 95\%RH$
2-6	Storage Environmental 储存环境	Temperature / 温度: $-40^{\circ}\text{C} \sim 85^{\circ}\text{C}$ Humidity / 湿度: $5 \sim 95\%RH$

**3. Standard measurement conditions (标准测试条件)**

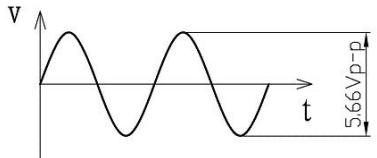
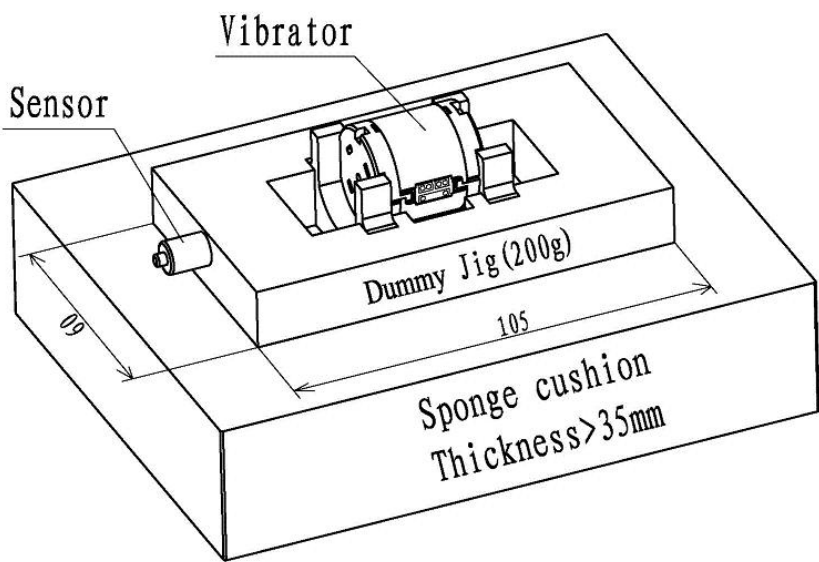
NO	ITEMS/项目	SPECIFICATION/规定	
3-1	Temperature/温度	$20 \pm 5^{\circ}\text{C}$	
3-2	Humidity/湿度	$(65 \pm 20\%)RH$	
3-3	Rated voltage 额定电压	AC Mode AC 模式	$2.0 \pm 0.05V_{rms}$ $(V_{p-p} = 5.66V)$ 
3-4	Operating Frequency 工作频率	@F0 ( $F0 \in 70 \pm 5Hz$ )	
3-5	Measuring method 测量方法	<p>Place Vibrator horizontally (Lock the Vibrator on a 200g dummy jig)                      振动器水平放置 (固定在 200 克的测试夹具上)</p> <p>The direction of the sensor as same as the direction of Vibrator vibration (As item 4-2)                      传感器检测方向和振动器振动方向保持一致。(参见项目 4-2)</p> 	

**4. Product performance (制品性能)**

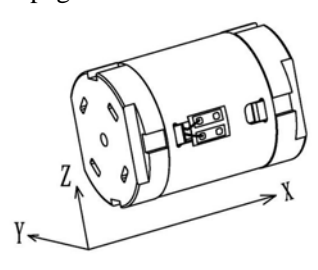
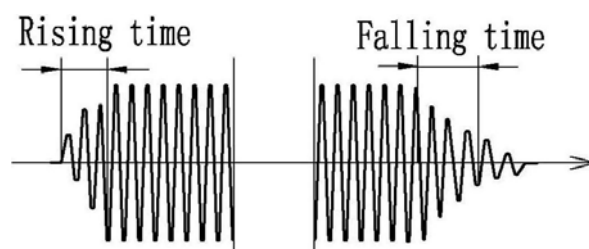
NO	Items(项目)	Requirements (要求)	Conditions Or Remark (条件/备注)
4-1	Shape size 外形尺寸	$\phi 22*30$ ( mm) not included Welding lead position 不包含引线焊接部位	Details refer to page 8 
4-2	Vibration direction 振动方向	X axis	
4-3	Weight/重量	36±2g	/
4-4	Resonant Frequency 谐振频率	70±5Hz	/
4-5	Operating voltage 工作电压	Maximum 3.0Vrms Sine wave/正弦波	采用较高电压工作时，请将工作频率请设置在 f0 或附近，否则可能因电流过大造成温升过高。 When working with high voltage, please set the working frequency at or near F0, otherwise the temperature rise may be too high due to excessive current.
4-7	Acceleration 振动加速度	≥ 1.3G(2.6Gpp)@F0	Sine wave 1.2Vrms (3.40Vp_p)
		≥ 2.5G(5.0Gpp)@F0	Sine wave 2.0Vrms (5.66Vp_p)
		≥ 3.5G(7.0Gpp)@F0	Sine wave 2.5Vrms(7.07Vp_p)
4-8	Rise time 启动时间	≤60ms	Rise to 90% of the nominal acceleration 加速度上升到典型值的 90% 
4-9	Falling time 断开时间	≤100ms	Down to 10% of the nominal acceleration 加速度下降到典型值的 10%
4-10	Rated current 额定电流	≤60mArms	@f0 Sine 1.2Vrms
		≤200mArms	@other frequency Sine 1.2Vrms
		≤100mArms	@f0 Sine 2.0Vrms
		≤300mArms	@other frequency Sine 2.0Vrms

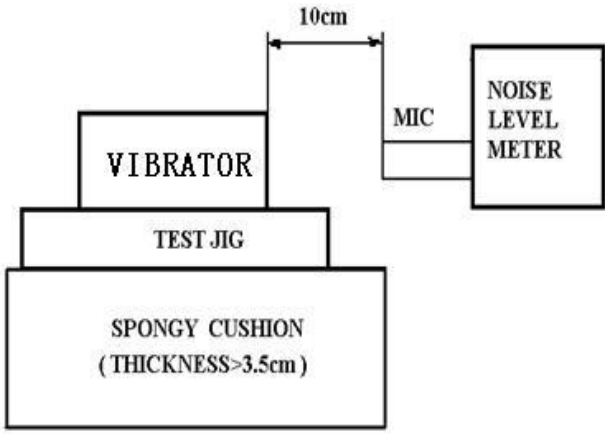
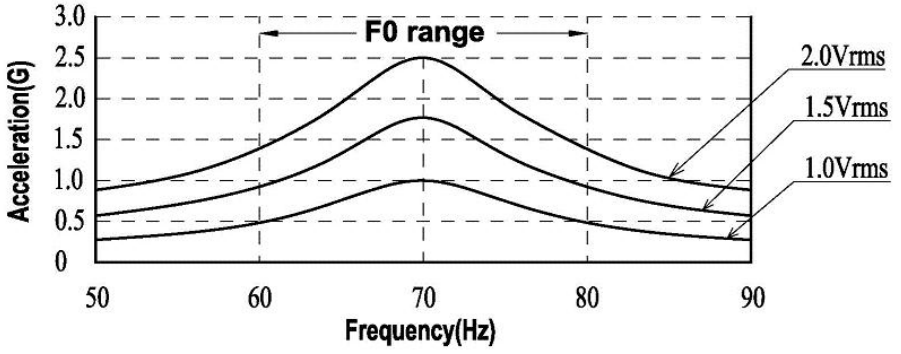
4-11	Terminal resistance 端子电阻	6.5±0.6Ω	AT 20°C
4-12	Insulation resistance 绝缘电阻	10MΩ(Min)	100V DC, Between the vibrator terminal and case.测试电压 DC100V,端子和外壳间。
4-13	Operating Attitude 工作姿态	All direction (全方向)	
4-14	Mechanical Noise 机械噪音	45dB-A (MAX)	<p>At rated voltage and load; F0 , Background noise 35dB-A (MAX)/在额定电压, 额定负载下测试, 背景噪音不超过 35dB.</p> 
4-15	Voltage- Acceleration Characteristics 输入电压—加速度特性曲线		

### 5. External performance (外观性能)

it should not remarkable wound and deleterious defect, No distortion、rust、stain, etc.不应有明显的划伤、有害缺陷, 无变形, 锈蚀, 污迹等。

**6. Reliability test 可靠性试**

NO	Items(项目)	Standard test conditions(标准试验条件)	Judgment (判定)
6-1	Life test 寿命试验	Lock the vibrator on a test fixture ( 200g JIG ) 振动器固定在 200g 的测试夹具上。 Temperature/温度: 25±5℃ Humidity/湿度: 65±20%RH Sine wave 1.2Vrms, f=60Hz 正弦交流电 1.2Vrms, 频率 60Hz Test model/试验形式: ON Total time:1000hours(1000 小时/42Days)	After the test, vibrator shall be satisfy with specified in item 6-8 试验结束后, 振动器应满足 6-8 中规定的要求。
6-2	Low temp Storage 低温存放试验	Temperature (温度): -20±2℃ Test time (试验时间): 240 hours	After the test, After 2 hours placed in ordinary temperature and humidity, vibrator shall be satisfy with specified in item 6-8 试验结束后, 在常温常湿中放置 2 小时后, 振动器应满足 6-8 中规定的要求
6-3	High temp storage 高温存放试验	Temperature (温度): 60±2℃ Test time (试验时间): 240 hours	
6-4	Heat shock 温度冲击	-30℃/+65℃ 2hours/cycle,24cycles. 低温-30℃, 高温+65℃, 2 小时切换, 24 个循环	
6-5	Humidity storage 湿热存放试验	Temperature (温度): 65±2℃ Humidity (湿度): 95%RH Test time (试验时间): 240hours	
6-6	Drop test 跌落试验	Dummy JIG 200g , drop to the granite floor. 治具 200g, 自由落下到花岗岩板上 Height/高度: 1.2m Direction/方向: 6 faces and 12 sides of the JIG . Times/次数:Each direction 1 drop, totaling 18 times. 每方向跌落 1 次, 共计 18 次	After the test, vibrator shall be satisfy with specified in item 6-8 试验结束后, 振动器应满足 6-8 中规定的要求。
6-7	Repetitive Drop Test 微跌试验	JIG/治具: 200g Height/高度: 7cm impact surface/冲击面: steel floor Times/次数: Front and back each 2500 drops	
6-8	AFTER TEST REQUIREMENTS/试验后特性判定		
	1、 Acceleration within ±30% from initial./加速度变化在初始值的±30%内;		
	2、 Insulation resistance within±20% from initial./绝缘电阻变化在初始值的±20%内;		
	3、 Terminal resistance within±20% from initial./ 端子电阻变化在初始值的±20%内;		
4、 No signs of corrosion/无明显腐蚀迹象			

7. Outline drawing (外形图)

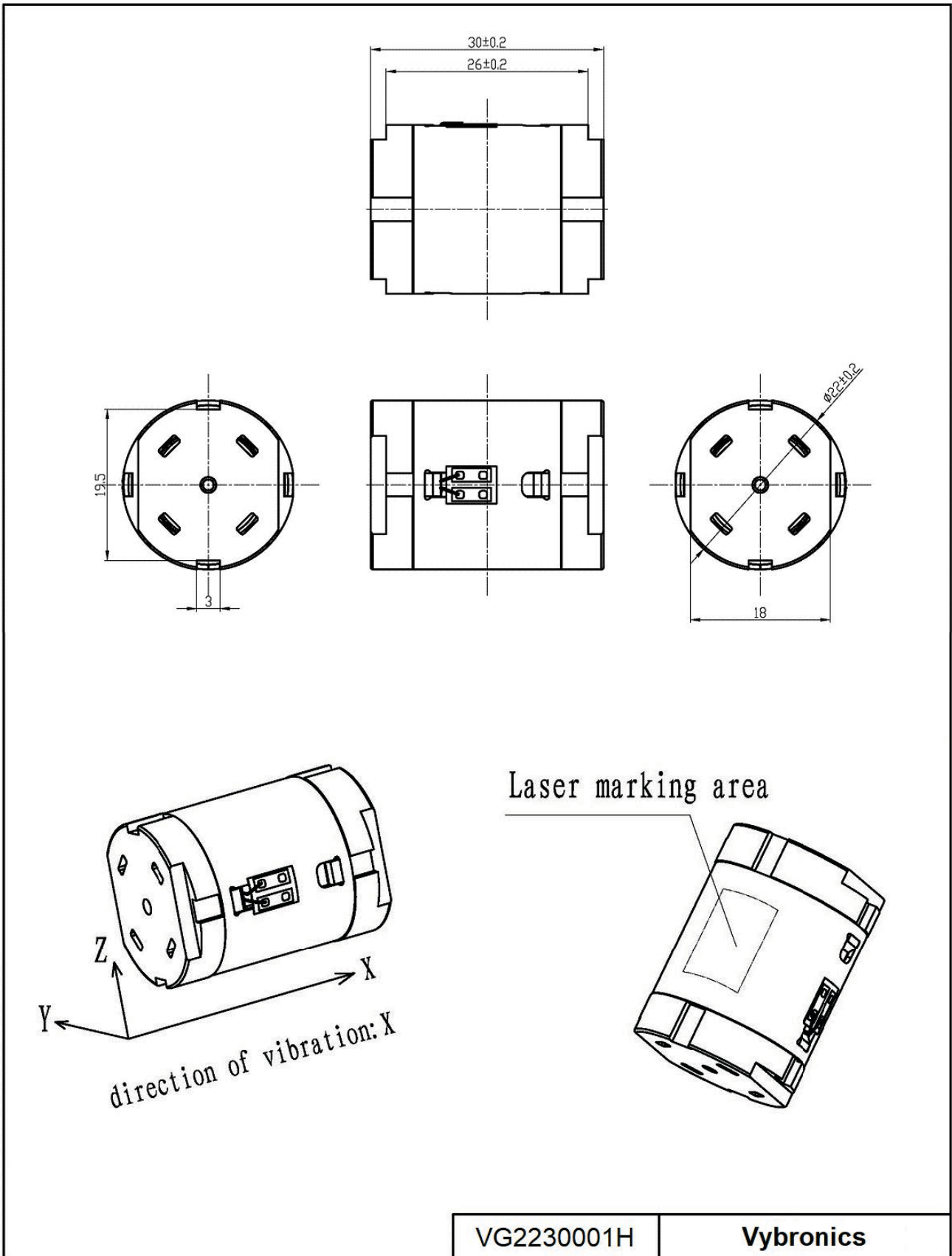



**8. Encoding rules 试码规则**

To be determined according to customer's requirements

依据客户需求确定

**9. Packaging requirements 包装要求**

50 pcs per box, 5 boxes per bundle, 2 bundles per box, 500 total.

每盒 50PCS, 每捆 5 盒, 每箱 2 捆, 共 500PCS

**10. Caution for Use 使用注意事项**

10-1. Please use vibrator in the specification of this specification. Otherwise the service life and performance of the vibrator will be affected. 请在本规格书规范内使用振动器, 否则会影响振动器的使用寿命和性能。

10-2. Make arrangement to limit the storage period to 6 months or less. 请在 6 个月内使用。

10-3. Please do not push the load of 15N or more on the surface of the vibrator, when exceeding 20N, it causes the trouble. 振动器表面承载压力不得超过 20 牛顿, 否则可能会导致功能故障。

10-4. Vibrators should be firmly fixed in the direction of vibration (Recommended Installation Force 5-8N), Otherwise it will be prone to noise. 振动器应牢牢固定在振动方向上 (推荐安装力 5-8N), 否则容易产生噪声。

10-5. Please lay the vibrators carefully in transportation to avoid any serious damage to the vibrator body or its electric function because of collision. 在运输过程中应小心轻放, 避免振动器碰撞受损

10-6. when soldering FPCB, The soldering iron temperature does not exceed 350 degrees and the soldering time per spot does not exceed 3 seconds. 焊接 FPCB 时, 电烙铁温度不超过 350°, 每个点焊接时间不超过 3 秒。

10-7. Vibrators can't be used in high temperature, High humidity and corrosive gas environment.

振动器不能在高温、高湿度和有腐蚀性气体环境中使用。

10-8. The vibrator has a strong magnet, So please be aware that it has a magnetic force on the surface of the bracket.

振动器有一个强的磁铁, 因此请注意, 它的支架表面有磁力。

10-9. Under the conditions of meeting this specification, our company can change the material, size and shape of parts to improve quality, performance or production efficiency. 在满足本规范的前提下, 我司可以改变零件材料、尺寸及形状来改善品质、性能或生产效率。

10-10. If there is any argument on vibrator performance and/or life, judgment is to be made base on this specification only.

如对振动器的性能和 (或) 寿命有任何争议, 仅基于此规格书作出判断。