

3M™ Water Filtration Products

SPEC# _____

QUANTITY _____



models:

DP295-CL

3M™ Water Filtration Products Model DP295-CL dual port water filtration system helps to provide consistent high quality water for the multiple applications of cold beverages, ice and coffee at a combined flow rate of up to 5 gpm (18.9 lpm). Two separate flow streams exit the manifold. Both streams have reduced sediment, chloramines, chlorine taste and odor. One stream has added scale inhibition media from a dedicated cartridge to help reduce the ability of calcium and magnesium to precipitate as hard scale on the evaporator plates of an ice machine and/or the heating coils of a coffee brewer. The second stream supplies cold beverage dispensers and includes no added scale inhibitor.

PRODUCT BENEFITS

- One system with dual outlet connections simultaneously supplies cold beverage dispensers, ice machines and coffee brewers.
- Up to 5 gpm (18.9 lpm) total flow of water especially treated for consistent great tasting cold beverages, clearer and consistent ice and the perfect cup of coffee or tea.
- NSF and/or FDA CFR-21 compliant materials.
- Proprietary carbon block technology reduces chloramines, chlorine taste and odor for great tasting cold beverages, ice and coffee.
- Reduction of scale build-up on evaporator plates and heating coils from a controlled forced-feed orifice addition of scale inhibitor, as tested by 3M.
- Sanitary Quick Change (SQC) encapsulated cartridge design allows for fast and easy cartridge change-outs with a ¼ turn.
- ¾" NPT horizontal inlet and outlet ports allow direct or easily adaptable connections to existing plumbing lines.
- Expansion kit available to serve higher capacities and flow rates.
- Auxiliary inlet gauge port allows optional monitoring of differential water pressure .
- Manifold includes outlet check valves and vent valve.

PRODUCT SPECIFICATIONS

Model Number	Part Number	Reduction Claims	Nominal Micron Rating	Capacity	Service Flow Rate	Application	Replacement Cartridge	Sizing
DP295-CL	56242-04	Sediment, Chloramines ¹ , Chlorine Taste & Odor, Scale	5.0	60,000 gallons (227,100 liters)	5.0 gpm (18.9 lpm)	Most Potable Water	DP295-CL CARTPAK (56138-18) (HF95-CL (Qty 2) & HF8-S)	For simultaneous operation of carbonators, coffee brewers and ice machines

¹ As tested and certified by independent third party laboratory



DP295-CL

3M™ Water Filtration Products

SPEC# _____
QUANTITY _____
MODEL NUMBER _____
PART NUMBER _____

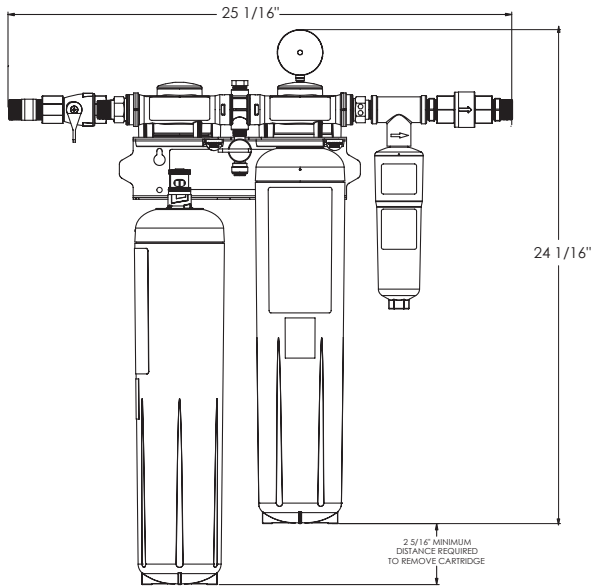

⚠ WARNING: To reduce the risk associated with the ingestion of contaminants:

- Do not use with water that is microbiologically unsafe or of unknown quality without adequate disinfection before or after the system.

3M Purification Inc. recommends regularly scheduled maintenance and replacement of the filter cartridge(s) in order for the product to perform as advertised/sold. 3M Purification Inc. shall not be liable for system failures due to improper maintenance.

LIMITED WARRANTY

3M Purification Inc. warrants this Product will be free from defects in material and workmanship for five (5) years from the date of purchase: The filter cartridge or filter membrane is warranted to be free from defects in material and workmanship for one (1) year. This warranty does not cover failures resulting from abuse, misuse, alterations or damage not caused by 3M Purification Inc. or failure to follow installation and use instructions. No warranty is given as to the service life of any filter cartridge or membrane as it will vary with local water conditions and water consumption. **3M PURIFICATION INC. MAKES NO OTHER WARRANTIES OR CONDITIONS, EXPRESS OR IMPLIED, INCLUDING, BUT NOT LIMITED TO, ANY IMPLIED WARRANTY OR CONDITION OF MERCHANTABILITY OR FITNESS FOR A PARTICULAR PURPOSE OR ANY IMPLIED WARRANTY OR CONDITION ARISING OUT OF A COURSE OF DEALING, CUSTOMER OR USAGE OF TRADE.** If the Product fails to satisfy this Limited Warranty during the warranty period, 3M Purification Inc, at its option, will replace the Product or refund your Product purchase price. This warranty does not cover labor. **The remedy stated in this paragraph is Customer's sole remedy and 3M Purification Inc.'s exclusive obligation. For additional information, see the entire Limited Warranty located in the product Installation and Operating Instruction Manual.**

Limitation of Liability. 3M Purification Inc. will not be liable for any loss or damage arising from this 3M Purification Inc. product, whether direct, indirect, special, incidental, or consequential, regardless of the legal theory asserted, including warranty, contract, negligence or strict liability. Some states and countries do not allow the exclusion or limitation of incidental or consequential damages, so the above limitation or exclusion may not apply to you.

SPECIFICATIONS

- System includes a two cartridge manifold with built-in pressure gauge, inlet water shut-off valve, outlet check valves, mounting brackets, two cartridge filters and a dedicated external scale inhibition cartridge.
- Auxiliary inlet gauge port allows optional monitoring of differential water pressure.
- Inlet and outlet plumbing connections are 3/4" NPT (choice of male or female is included).
- Filter cartridge are o-ring seal type.
- System maximum operating pressure of 125 psi (862 kPa) and operating temperature of 100° F (37.8°).
- System materials are NSF and/or FDA CFR-21 compliant.
- Cartridges are sanitary in design, requiring no contact with the filter media during cartridge change-out.
- Filter cartridges require no pre-activation.
- Shipping weight: Contact factory.
- Operating weight: 28.9 lbs. (13.1 kg)

IMPORTANT: INSTALLATION TIPS

These installation tips are for informational purposes only and are not intended to be used as actual installation instructions. CAUTION: To reduce the risk associated with property damage due to water leakage:

- **Read and follow** Use Instructions before installation and use of this system.
- Installation and use **MUST** comply with all state and local plumbing codes.
- **Protect from freezing**, remove filter cartridge when temperatures are expected to drop below 40°F (4.4°C).
- **Do not install on hot water supply lines.** The maximum operating water temperature of this filter system is 100°F (37.8°C).
- **Do not install** if water pressure exceeds 125 psi (862 kPa). If your water pressure exceeds 80 psi (552 kPa), you must install a pressure limiting valve. Contact a plumbing professional if you are uncertain how to check your water pressure.
- **Do not install** where water hammer conditions may occur. If water hammer conditions exist you must install a water hammer arrester. Contact a plumbing professional if you are uncertain how to check for this condition.
- The disposable filter cartridge **MUST** be replaced every 12 months, at the rated capacity or sooner if a noticeable reduction in flow rate occurs.



3M Purification Inc.
400 Research Parkway
Meriden, CT 06450 U.S.A.
Toll Free: 1-866-990-9785
Worldwide: 203-237-5541
Fax: 203-238-8701
www.3mpurification.com
www.3mfoodservice.com

3M is a trademark of 3M Company.
© 2013 3M Company. All rights reserved.
70020302066 REV 0313