

# Customer Information Sheet

DRAWING No.: S25-XX2

IF IN DOUBT - ASK

©

NOT TO SCALE

THIRD ANGLE PROJECTION

ALL DIMENSIONS IN mm

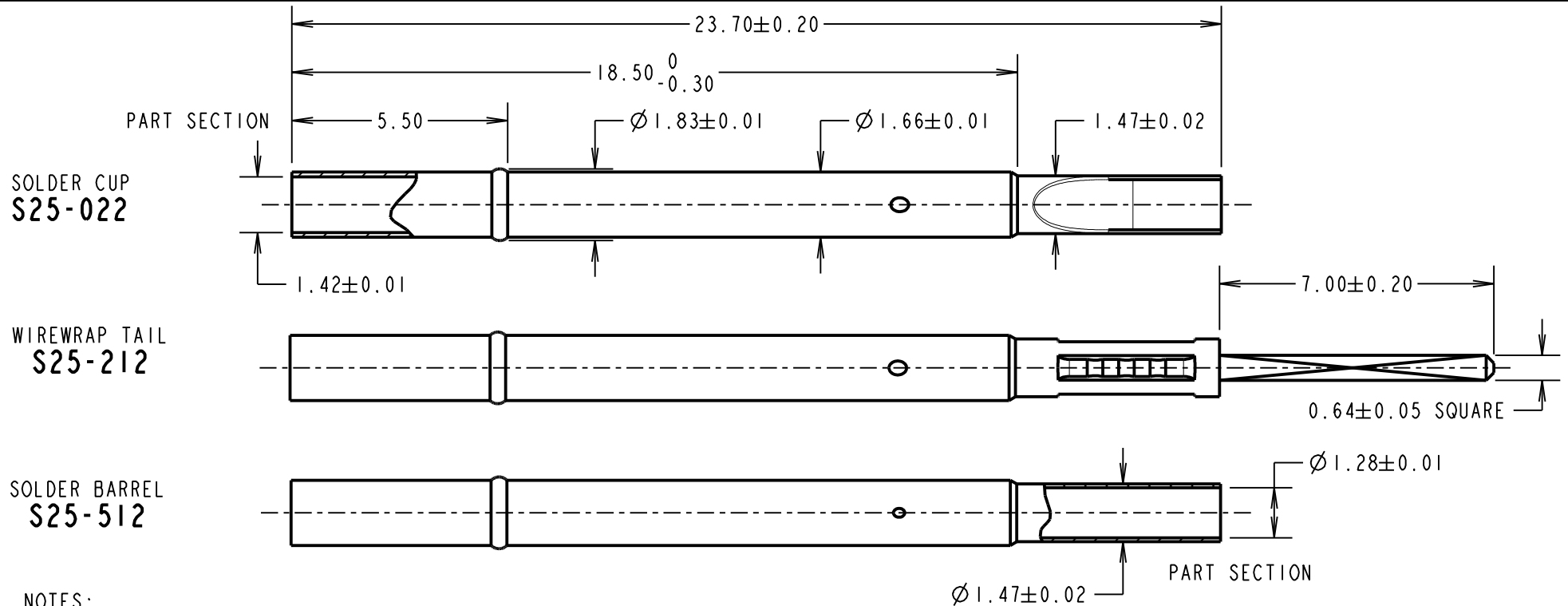

**NOTES:**

1. TO BE USED WITH PROBES P25-0822 AND P25-XX23.
2. SUITABLE FOR A MINIMUM DISTANCE BETWEEN CENTRES OF 2.54mm.
3. SPECIFICATIONS FOR PROBE PERFORMANCE ARE GIVEN ON THE PROBE DRAWING.
4. RECOMMENDED HOLE SIZES: ∅1.75mm
5. S25-022 & S25-512 ARE SUITABLE FOR USE WITH 22, 24, 26, 28 & 30 AWG WIRE (SOLDER).
6. PLATING = 0.05µ GOLD OVER 2.03-3.05µ NICKEL.

MSP	4	28.01.16	13249
NAME	ISS.	DATE	C/NOTE
APPROVED: M.PERREN			
CHECKED: S.BENNETT			
DRAWN: M.PERREN			
CUSTOMER REF.:			
ASSEMBLY DRG:			

ORDER CODE:  
**S25-XX2**  
 SPRING PROBE  
 SLEEVE (SEE ABOVE)

**HARWIN**

www.harwin.com  
 technical@harwin.com

THIS DRAWING AND ANY INFORMATION OR DESCRIPTIVE MATTER SET OUT HEREON ARE CONFIDENTIAL AND COPYRIGHT PROPERTY OF THE HARWIN GROUP AND MUST NOT BE DISCLOSED, LOANED, COPIED OR USED FOR MANUFACTURING, TENDERING OR FOR ANY OTHER PURPOSE WITHOUT THEIR WRITTEN PERMISSION.

**TOLERANCES**  
 X. = ±1mm  
 X.X = ±0.50mm  
 X.XX = ±0.10mm  
 X.XXX = ±0.01mm  
 ANGLES = ±5°  
 UNLESS STATED

**MATERIAL:**

BRASS

**FINISH:** SEE ABOVE

**S/AREA:**

mm<sup>2</sup>

**TITLE:**

2.54mm MIN. CENTRE TWO-PIECE  
 SPRING PROBE SLEEVE

**DRAWING NUMBER:**

**S25-XX2**

SHT  
 2  
 OF  
 2