

Airborne™ Embedded Wireless Device Server and Ethernet Solution Modules Serial to 802.11b/g & Ethernet to 802.11b/g

WLNG-XX-DP551 Series

The Most Secure, Rugged and Reliable Wi-Fi Modules

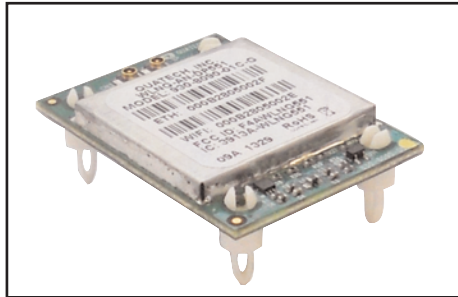

The Airborne line of highly-integrated 802.11 wireless modules allow OEMs to Wi-Fi enable devices used in an array of machine-to-machine (M2M) applications. By providing all of the necessary RF technology, networking stacks and advanced security features in a compact, single-board package, Quatech provides OEMs with the simplest and most cost-effective solution for embedding Wi-Fi into their product designs.

Big Performance in Small and Ruggedized Package

The WLNG-xx-DP551 series delivers the industry's most rugged, highly-integrated, embedded Wi-Fi module solution. Airborne modules meet extended operating temperature and shock/vibration specifications of the most demanding M2M applications.

Utilizing a 32bit ARM9 processor and the high-performance Atheros AR6002 802.11 radio, the new Airborne modules deliver increased transmit power and receive sensitivity, contributing to superior range performance.

The new Airborne SpeedLink roaming feature provides enhanced connection reliability, enabling OEM devices to roam freely within a wireless network without loss of data or connection.

Airborne PowerSave firmware enables OEMs to maximize efficiency and reduce power consumption by as much as 70%. PowerSave capability is especially critical for battery-powered mobile devices.

Flexible & Easy to Integrate

Airborne incorporates support for both serial to Wi-Fi and Ethernet to Wi-Fi communications. Utilizing Airborne's PortFlex capability, OEMs may configure via software any combination of UART, SPI, Ethernet, GPIO and 802.11 interfaces. Each individual port can be independently configured.

OEMs can choose to incorporate both transmit and receive diversity capability in their designs by utilizing the two U.FL antenna connectors on the WLNG-xx-DP551 series modules.

The WLNG-xx-DP551 modules are footprint and pin-compatible with their predecessors, dating back to the original introduction of the Airborne product family. Quatech's commitment to maintaining hardware and software compatibility assures OEMs of a simple, future-proof migration path even as wireless technology evolves.

Enterprise Class Security

Quatech's multi-layered security approach addresses the requirements of Enterprise-class networks and corporate IT departments. These advanced security features include wireless security (802.11i/ WPA2 Enterprise); network security (EAP authentication and certificate support); built-in firewalls on the Ethernet and WLAN interfaces; secure communications (built-in SSH functionality and fully encrypted data tunnels for secure management and data transfer); and device security (multi-level encryption capability to protect sensitive device configuration data).

A unique Airborne security feature is the onboard delivery of certificates to the module and management of all authentication processes without requiring interaction from the host. This substantially reduces the resource requirements for OEMs whose devices operate in Enterprise-Class wireless.

KEY FEATURES

- 802.11b/g WiFi Radio with 32bit ARM CPU
- Airborne PowerSave firmware reduces power consumption and extends battery life in mobile devices
- Extended Operating Temperature Range (-40°C to +85°C) and environmental specifications
- Airborne SpeedLink roaming provides enhanced connection reliability
- Advanced Enterprise Class wireless security (WPA2-Enterprise, WPA, WEP, EAP)
- Onboard certificate delivery and storage
- Fully integrated serial bridge and network stack
- Airborne PortFlex capability enables any combination of comm ports (UART, SPI, GPIO, Ethernet and 802.11 interfaces)
- Reduces need for RF, networking and communications expertise
- Quick time to market and reduced integration costs
- FCC Part 15 Class B Sub C Modular Approval minimizes regulatory requirements
- Backwards compatible with previous generations of Airborne embedded modules
- 5 year warranty

Markets

Quatech has delivered high-performance device networking and connectivity solutions all over the world since 1983. Airborne embedded modules operate in a wide-range of M2M applications:

- Industrial Automation & Control
- Energy Management
- Medical devices
- Retail / Point of Sale products
- Vehicle Telematics
- Military Communications
- Material Handling & Logistics
- Test & Measurement
- Security & Access control

Block Diagram

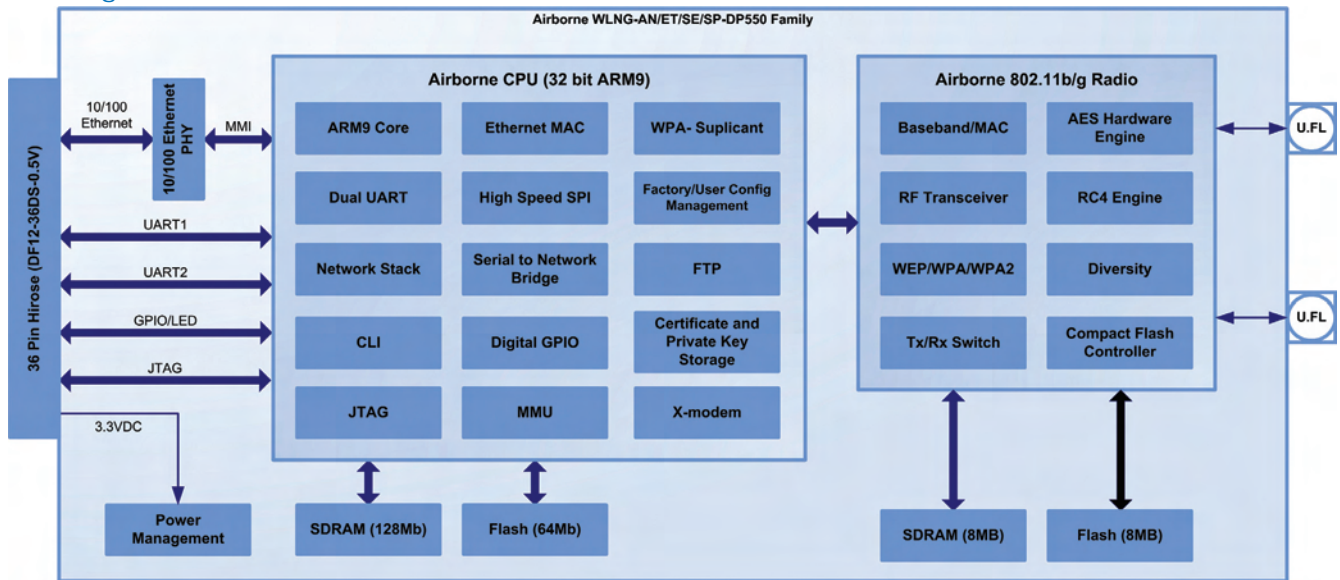

Mechanical Outline

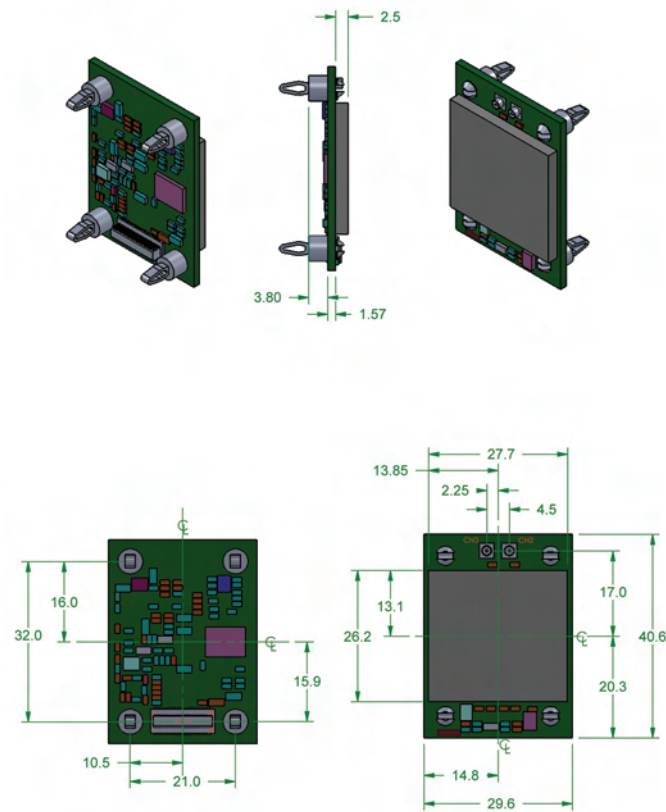

Specifications

Technology	IEEE 802.11b/g, WiFi compliant
Frequency	2.4 - 2.4835 GHz (US/Canada/Europe) 2.4 - 2.497 GHz (Japan)
Modulation Technology	DSSS, CCK, OFDM
Modulation Type	DBPSK, DOPSK, CCK, BPSK, QPSK, 16QAM, 64QAM
Network Access Modes	Infrastructure, Ad Hoc
Channels	USA/Canada: 11 channels Europe: 13 channels France: 7 channels Japan: 14 channels (13 channels for 802.11g)
Wireless Data Rate	802.11b = 11, 5.5, 2, 1 Mbps 802.11g = 54, 48, 36, 24, 18, 12, 9, 6 Mbps
MAC	CSMA/CA with ACK, RTS, CTS
Network Protocols	TCP/IP, ARP, ICMP, DHCP, DNS, UDAP, TFTP, UDP, PING
Receive Sensitivity	54Mb/s = -75dBm 36Mb/s = -82dBm 18Mb/s = -88dBm 6Mb/s = -93dBm 11Mb/s = -88dBm 1Mb/s = -98dBm
Security Protocols	Disabled, WEP 64 & 128bit, WPA (TKIP), WPA (AES), WPA2 (AES), 802.1x (EAP) Supplicant 802.11i, WPA & WPA2 Enterprise supplicants (EAP-TLS, EAP-TTLS(MSCHAPv2), EAPTTLS(MD5S), EAP-PEAPv0(MSCHAPv2, LEAP), EAP-FAST, LEAP) Supports Certificates and Private Key Upload and Storage (Multiple)
Antenna	Two (2) U.FL coaxial connectors, 50 ohms, supports Rx and Tx diversity
Supply	3.3VDC +/-5%, 850mA (MAX)
Supply In-rush Current	3000mA (MAX) for 20ms
DC Characteristics	Operating Current (Tx, 802.11g) = 240mA Typ. Operating Current (Rx, 802.11g) = 310mA Typ. Power Save (Doze) = TBD mA Typ. Power Down (Sleep) = TBD mA Typ.
Environmental	Operating Temperature: -40°C - +85°C, Storage: -55°C - +150°C Relative humidity: 5% - 95% (non-condensing) Vibration: 20G peak-to-peak, 20Hz-2KHz swept Shock: 1500G peak-to-peak, 0.5mS duration
Interfaces	Dual UART (960KBAUD), RS232/ 422/ 485, SPI (1bit/20MHz), 10/100 Ethernet, PortFlex
Digital I/O	8 GPIO
LED Indicators	4 indicator LED signals (RF_ACT, POST, CONNECT, RF_LINK), Signal Strength
Connector	36 pin High Density SMT connector from Hirose (DF12-36DS-0.5V), 4mm Height
Agency Approvals	North America: FCC Title 47 Part 15 Class B Sub C Intentional Radiator, IOC RSS210 Europe: CE ETSI EN300 328 RoHS & WEEE compliant

Model Selection Guide

Model #	Description
WLNG-BR-DP551	802.11b/g, 10/100 Ethernet bridge, Advanced Enterprise Security
WLNG-ET-DP551	802.11b/g, 10/100 Ethernet adapter, Advanced Enterprise Security
WLNG-AN-DP551	802.11b/g, UART interface, Advanced Enterprise Security
WLNG-SE-DP551	802.11b/g, UART with RS-232/422/485 Driver Control, Advanced Enterprise Security
WLNG-SP-DP551	802.11b/g, SPI interface, Advanced Enterprise Security