

PRODUCT DATA SHEET

Part Number : **CM44**

Type	Size	Rating	Description
Incandescent	T10	6.3V 250mA	T-3¼ Miniature Bayonet lamp

Dimensions(mm):

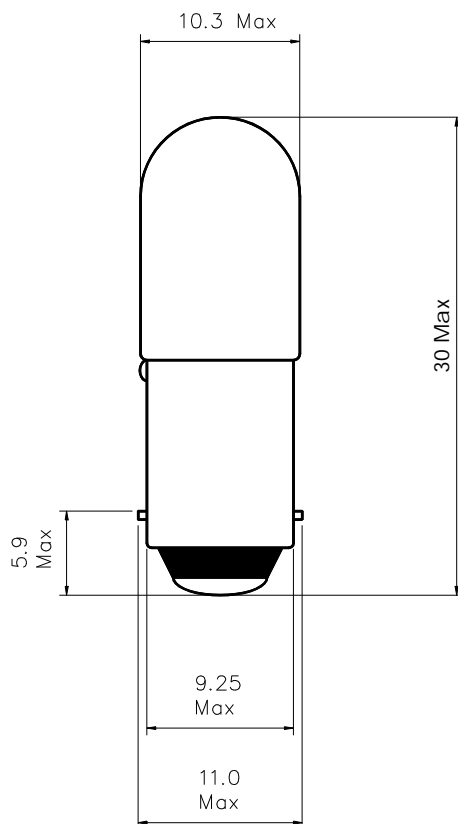

TEST VOLTS	CURRENT (mA)			LIGHT OUTPUT (Lm)			LIFE Hours
	Min.	Nom.	Max.	Min.	Nom.	Max.	
6.3	225	250	275	8.5	11.3	14.1	3000

Notes:

- Lamp base BA9s/13 in accordance with IEC61-1, (BS EN 60061-1) sheet 7004-14-x.
- Lamp marking CML44 6.3V 250mA
- Filament shape C-2R
- Light centre length 19 - 21mm
- RoHS compliant

Issue # 1 : 14 May 09