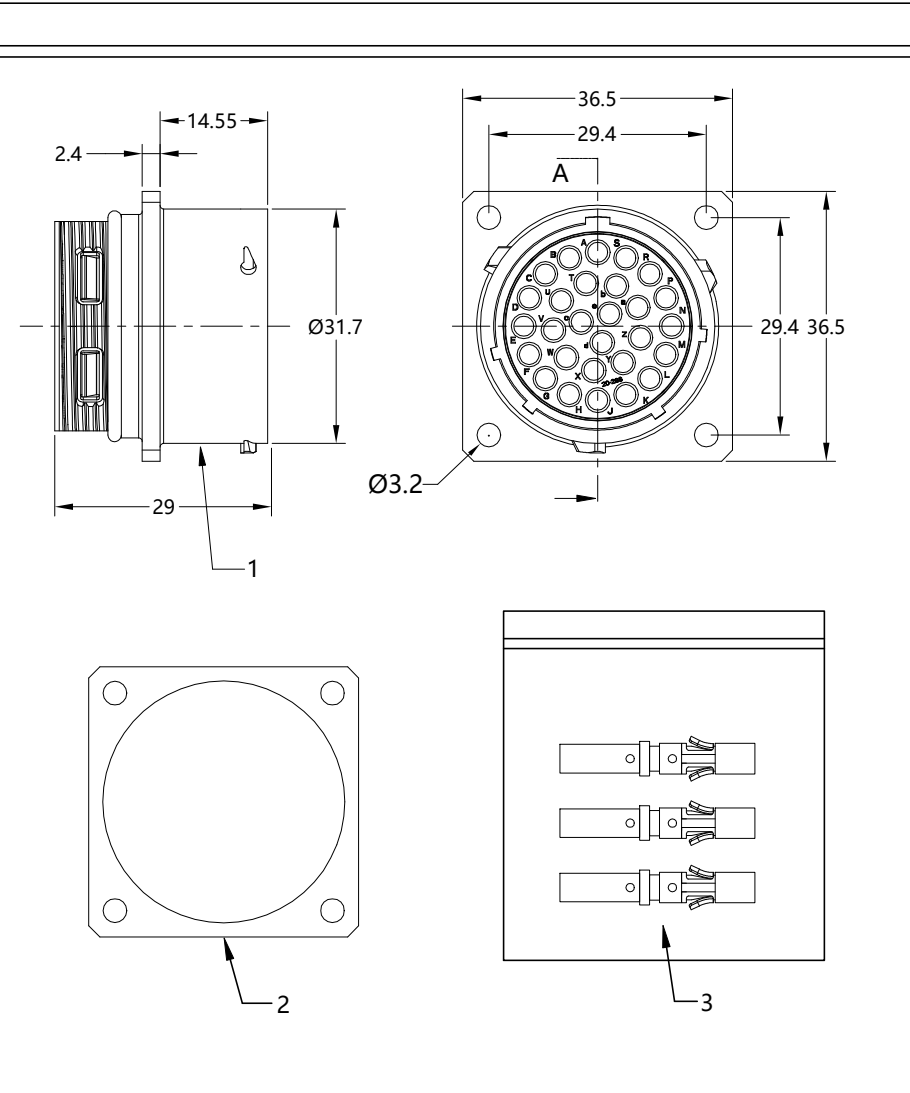
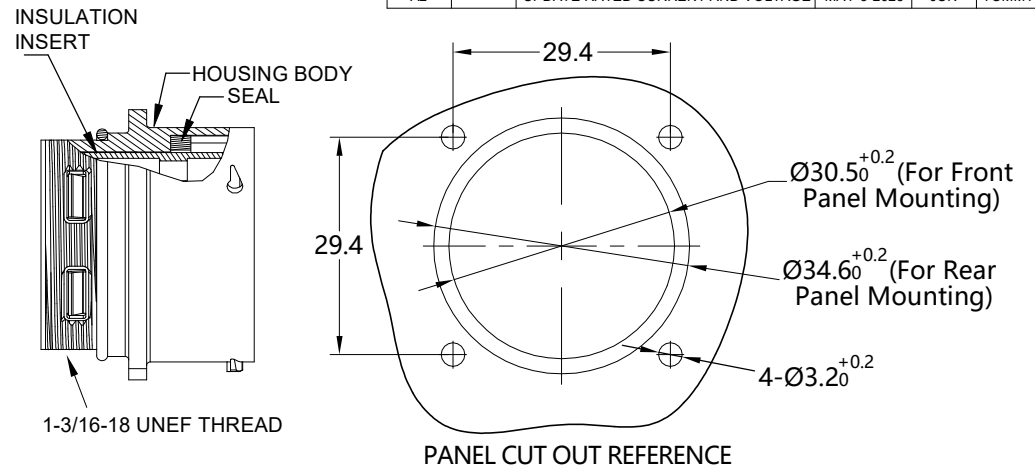

ILLUSTRATION: COMPLETE KIT



REVISIONS					
REV	ECO	DESCRIPTION	DATE	BY	APPR
A1	-	RELEASED DRAWING	JAN-5-2023	JUN	TOMMY
A2	-	UPDATE RATED CURRENT AND VOLTAGE	MAY-3-2023	JUN	TOMMY



NOTES:

- CONTACT BARREL RANGE: 16AWG TO 18AWG
- RECOMMENDED CRIMP TOOLS:
HAND CRIMPER: MFX-3959
PNEUMATIC CRIMPER: MFX-3960
- EXTRACTION TOOL: QXRT16
- MATERIALS:
HOUSING BODY: ZINC DIE CAST, NICKEL PLATED.
INSULATION INSERT: PA66, UL94/V-0.
CONTACT: BRASS, GOLD FLASH PLATED
SEAL: NBR
- ELECTRICAL DATA:
a) CURRENT (MAX): 3A.
b) RATED VOLTAGE (MAX): 500V (AC/DC).
c) INSULATION RESISTANCE (MIN): 5000M OHMS.
d) TEST VOLTAGE (BETWEEN CONTACTS): 3050 V.
- TECHNICAL DATA:
a) TEMPERATURE RANGE: -40°C TO 105°C.
b) PROTECTION: IP67 (IP69K WHEN IN MATED CONDITION).
c) MATING CYCLES DURABILITY: 500 CYCLES (MIN).
d) VIBRATION RESISTANCE PER MIL-STD-202 METHOD 204.
e) THERMAL SHOCK PER MIL-STD-202 METHOD 207.
f) 48 HOUR SALT SPRAY PER MIL-STD-202 METHOD 101.
- ROHS COMPLIANT

QUANTITY	PART NUMBER	DESCRIPTION	ITEM
28	MS16M23F	CONTACT, SOCKET, SIZE 16	3
1	RTFD20B	SEAL PAD SIZE20	2
1	RT002028S*H	CONNECTOR	1

MATERIALS LIST			
UNLESS OTHERWISE SPECIFIED		SIGNATURES	
1) All dimensions are in metric (mm).		DATE	
2) Tolerances are as follows:		DRAWN: JUN MAY-3-2023	
1 PL DEC ±0.30		CHECKED: JOE MAY-5-2023	
2 PL DEC ±0.15		ENGINEER:	
3 PL DEC ±0.08		APPROVAL: TOMMY MAY-8-2023	
3) Note reference =		CUSTOMER:	
MATERIAL SPECIFICATIONS:		THIS DRAWING IS SUPPLIED FOR INFORMATION ONLY. DESIGN FEATURES, SPECIFICATIONS AND PERFORMANCE DATA SHOWN HEREON ARE THE PROPERTY OF THE AMPHENOL CORPORATION. NO RIGHTS OF REPRODUCTION ARE IMPLIED. ALL DIMENSIONS ARE SUBJECT TO NORMAL MANUFACTURING VARIATIONS.	
PROCESS SPECIFICATIONS:		SIZE TYPE DWG NO. REVISION	
NEXT ASSY:		B C- RT002028S*H-K A2	
		SCALE NONE SHEET 1 OF 1	

TITLE: ECO-MATE RECEPTACLE, SIZE 20, 28POS, SOCKET
 DWG NO.: CRT002028S*H-K
 REV: A2
 SH: 1
 OF: 1

Amphenol
 Sine Systems - www.amphenol-sine.com
 44724 Morley Drive
 Clinton Township, MI 48036