

66323 7.5 kV HIGH VOLTAGE, 6N140 TYPE HIGH SPEED ISOLATOR



09/15/2009

Features:

- High Current Transfer Ratio 1000% typical
- 7.5 kVdc Isolation
- Low input current requirement of 0.5 mA
- Integral Detector Die Faraday Shield for improved Common Mode Rejection

Applications:

- High Voltage Isolation
- Voltage Level Shifting
- Isolated Receiver Input
- Switching power supplies
- Medical systems

DESCRIPTION

The **66323** high voltage isolator consists of an 850 nm LED optically coupled to a high gain inverting photon detector. The isolator provides high CTR and low leakage currents over the specified temperature range of -40°C to +100°C. The isolator is built with hermetic components internally optically coupled and encased in a high temperature outer PPS plastic housing.

ABSOLUTE MAXIMUM RATINGS (T_A=25°C unless otherwise specified)

Isolation Voltage (Input to Output) (Note 2).....	7.5 kVdc
Operating Free-Air Temperature Range	-40°C to +100°C
Storage Temperature.....	-40°C to +100°C
Temperature (10 second, 1.6 mm from case) (Note 1).....	260°C

LED:

Peak Forward Input Current (2 μs duration).....	300 mA
Average Forward Input Current	50 mA
Reverse Input Voltage	3.0 V
Input Power Dissipation	100 mW

Output IC:

Supply Voltage - V _{CC}	-0.5V to 7.0 V (1 minute maximum)
Output Current - I _O	25 mA
Output Power Dissipation	40 mW
Output Voltage - V _O	18 V

Package Dimensions

Schematic Diagram

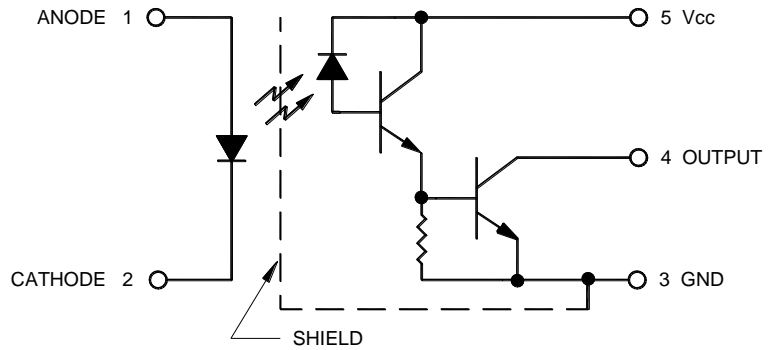
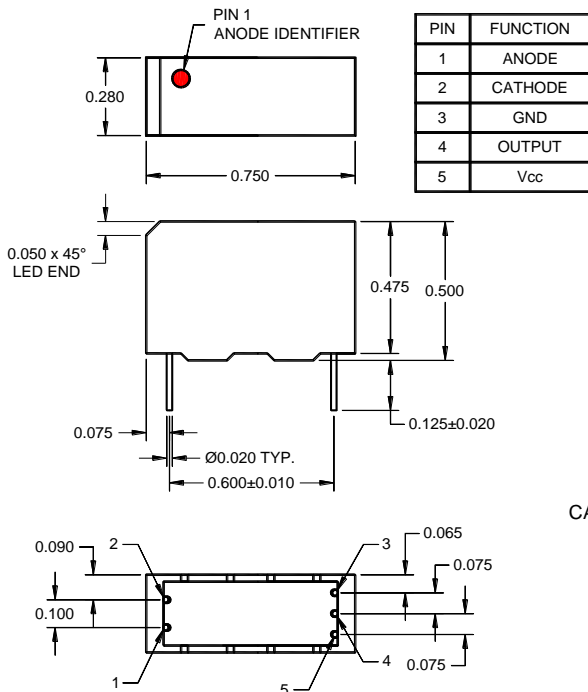

ALL DIMENSIONS ARE IN INCHES UNLESS OTHERWISE SPECIFIED

09/15/2009

ELECTRICAL CHARACTERISTICS ($T_A = -40^{\circ}\text{C}$ to $+100^{\circ}\text{C}$ unless otherwise specified)

PARAMETER	SYMBOL	MIN	TYP	MAX	UNITS	TEST CONDITIONS	NOTE
Input LED							
Input Forward Voltage	V_F		1.3	1.8	V	$I_F = 20 \text{ mA}$	
Reverse Current	I_R			100	μA	$V_R = 3.0 \text{ V}$	
Output IC							
Current Transfer Ratio	CTR	300	1000		%	$I_F = 0.5 \text{ mA}, V_O = 0.4 \text{ V}, V_{CC} = 4.5 \text{ V}$	3
		300	750			$I_F = 1.6 \text{ mA}, V_O = 0.4 \text{ V}, V_{CC} = 4.5 \text{ V}$	
		200	400			$I_F = 5.0 \text{ mA}, V_O = 0.4 \text{ V}, V_{CC} = 4.5 \text{ V}$	
Low Level Output Voltage	V_{OL}		0.1	0.4	V	$I_F = 0.5 \text{ mA}, I_{OL} = 1.5 \text{ mA}, V_{CC} = 4.5 \text{ V}$	
			0.2	0.4		$I_F = 5.0 \text{ mA}, I_{OL} = 10 \text{ mA}, V_{CC} = 4.5 \text{ V}$	
Logic High Output Current	I_{OH}		0.005	250	μA	$I_F = 2 \mu\text{A}, V_O = V_{CC} = 18 \text{ V}$	
High Level Supply Current	I_{CCH}		0.010	40	μA	$I_F = 0 \text{ mA}, V_{CC} = 18 \text{ V}$	
Low Level Supply Current	I_{CCL}		2	4	mA	$I_F = 1.6 \text{ mA}, V_{CC} = 18 \text{ V}$	
Input – Output Isolation Voltage	V_{I-O}	7500			V	$I_{I-O} = 25 \mu\text{A}$	2
Propagation Delay Time To High Output Level	t_{PLH}			60	μs	$I_F = 0.5 \text{ mA}, V_{CC} = 5.0 \text{ V}, R_L = 4.7 \text{ k}\Omega$	
				30		$I_F = 5.0 \text{ mA}, V_{CC} = 5.0 \text{ V}, R_L = 680 \Omega$	
Propagation Delay Time To Low Output Level	t_{PHL}			100	μs	$I_F = 0.5 \text{ mA}, V_{CC} = 5.0 \text{ V}, R_L = 4.7 \text{ k}\Omega$	
				10		$I_F = 5.0 \text{ mA}, V_{CC} = 5.0 \text{ V}, R_L = 680 \Omega$	
Typical Characteristics ($V_{CC} = 5\text{V}, T_A = 25^{\circ}\text{C}$)							
Input Capacitance	C_{IN}		60		pF	$V_F = 0, f = 1 \text{ MHz}$	
Coupling Capacitance (Input – Output)	C_{I-O}		1.5		pF	$V_F = 0, f = 1 \text{ MHz}$	2
Common Mode Transient Immunity At High Output Level	CM_H	500	1000		V/ μs	$V_{CM} = 50 \text{ Vp-p}, V_{CC} = 5.0 \text{ V}$ $R_L = 1.5 \text{ k}\Omega, I_F = 0$	4, 6
Common Mode Transient Immunity At Low Output Level	CM_L	500	1000		V/ μs	$V_{CM} = 50 \text{ Vp-p}, V_{CC} = 5.0 \text{ V}$ $R_L = 1.5 \text{ k}\Omega, I_F = 1.6 \text{ mA}$	5, 6

NOTES:

- The duration can be extended to 10 seconds maximum when flow soldering. Otherwise 5 seconds with soldering iron.
- Device considered a two terminal device with all Input pins (Anode and Cathode) shorted together and all Output pins (V_{CC} , GND and Output) shorted together.
- CURRENT TRANSFER RATIO is defined as the ratio of output collector current, I_O , to the forward LED input current, I_F , times 100%.
- CM_H is the maximum tolerable common mode transient to assure the output will remain in a HIGH logic state (ie. $V_O > 2.0 \text{ V}$).
- CM_L is the maximum tolerable common mode transient to assure the output will remain in a LOW logic state (ie. $V_O < 0.8 \text{ V}$).
- In applications where dv/dt may exceed 50,000 V/ μs (such as static discharge) a series resistor, R_{CC} , should be include to protect the detector IC from destructively high surge currents. The recommended value is $R_{CC} = 1 \text{ V}/(0.6 * I_F) \text{ mA}$.

SELECTION GUIDE

PART #	PART DESCRIPTION
66323-001	Commercial
66323-101	Screened