

TMC429-LI BOB Description

Document Revision V1.00 • 2021-Feb-01

Module Top View

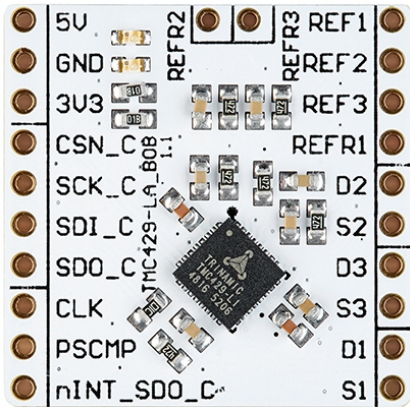

Features and additional Resources

- TMC429-LI triple-axis dedicated motion controller
- Supply voltage 3.3V or 5V
- Configuration and control via SPI
- 3x dedicated Step and Direction output
- Up to 32MHz input frequency
- Up to 1MHz step output frequency
- Board width 1.0", board height 1.0"
- 2x10 pin 0.1" header rows for pins/connectors
- Link to [additional information and IC Datasheet](#)
- Link to [Evaluation Kit](#)

Pin List

Left	Signal	Right	Signal
1	5V	11	REF1 (Left reference)
2	GND	12	REF2
3	3V3	13	REF3
4	CSN_C	14	REFR1 (right reference)
5	SCK_C	15	D2 (Direction 2)
6	SDI_C	16	S2 (Step 2)
7	SDO_C	17	D3 (Direction 2)
8	CLK (up to 32MHz)	18	S3 (Step 3)
9	PSCMP	19	D1 (Direction 2)
10	nINT_SDO_C	20	S1 (Step 1)

Bill of Materials

Pcs.	MPN	Value	Footprint	Description
1	MC0603X474K160CT	470nF,16V,10%	0603	Cap, Multicomp
2	MC0603B104K160CT	100nF,16V,10%	0603	Cap, Multicomp
6	MC0603B103K160CT	10nF/16V/10%	0603	Cap, Multicomp
2	LTST-C191TBKT-5A	20mA,2.8V,465nm	0603	LED, Lite-On
1	TMC429-LI	TMC429-LI	QFN32,5x5,0,5	PreDriver, TRINAMIC
1	MC0063W0603110K	10k	0603	Res, Multicomp
2	MC0063W060311K	1k	0603	Res, Multicomp
6	MC0063W060314K7	4k7	0603	Res, Multicomp

BOB Schematics

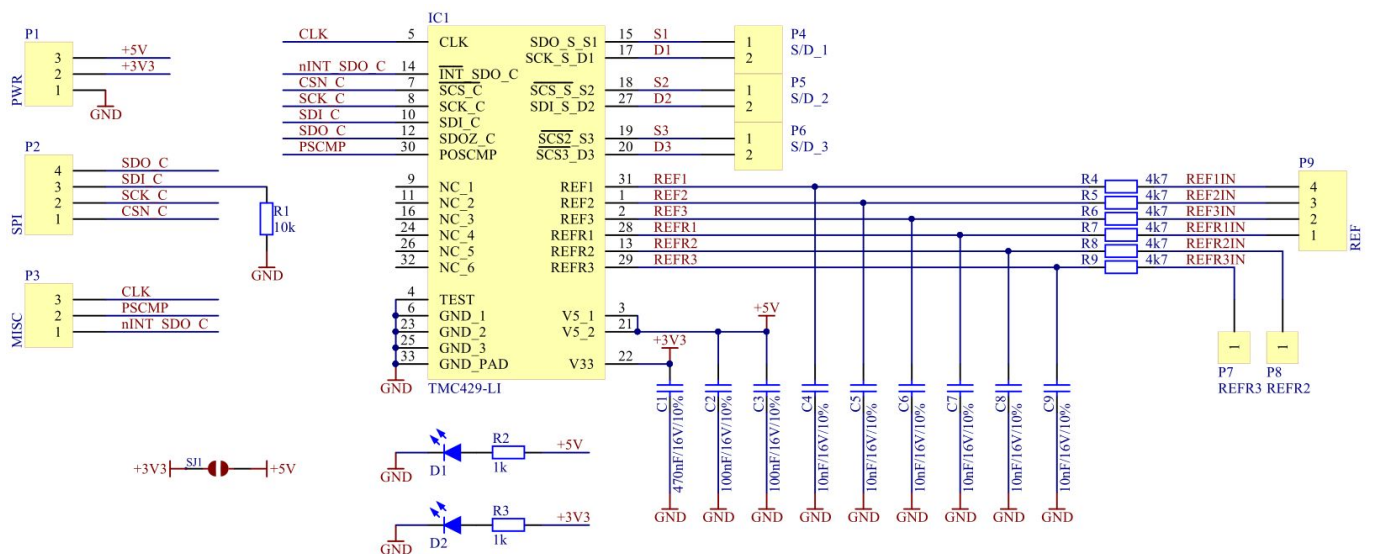

©2021 TRINAMIC Motion Control GmbH & Co. KG, Hamburg, Germany
 Download newest version at: www.trinamic.com

