

22 W auxiliary power supply for indoor air-conditioner using ICE5AR2280CZ

REF_5AR2280CZ_22W1

About this document

Scope and purpose

This document is a reference design for a 22 W auxiliary power supply for a residential air-conditioner unit with the latest fifth-generation Infineon fixed-frequency (FF) CoolSET™ **ICE5AR2280CZ**. The power supply is designed with a universal input compatible with most geographic regions and three outputs (+12 V/1.4 A isolated, +5 V/0.3 A isolated, +15 V/150 mA non-isolated).

Highlights of the auxiliary power supply for indoor air-conditioner unit are:

- Tightly regulated output voltages, high efficiency under light load and low standby power
- Comprehensive protection for a robust system
- Auto-restart protection scheme to minimize interruption and enhance end-user experience

Intended audience

This document is intended for power supply design engineers who are designing auxiliary power supplies for residential air-conditioner units that are efficient, reliable and easy to design.

Table of contents

About this document	1
Table of contents	1
1 System introduction	3
2 Reference board design	5
3 Power supply specifications	6
4 Circuit diagram	7
5 Circuit description	8
5.1 EMI filtering and line rectification.....	8
5.2 Flyback converter power stage.....	8
5.3 Control of flyback converter through fifth-generation FF CoolSET™ ICE5AR2280CZ	8
5.3.1 Current sensing	8
5.3.2 Feedback and compensation network.....	8
5.4 Unique features of the fifth-generation FF CoolSET™ ICE5AR2280CZ	9
5.4.1 Fast self-start-up and sustaining of V_{CC}	9
5.4.2 CCM, DCM operation with frequency reduction.....	9
5.4.3 Frequency jittering with modulated gate drive	9
5.4.4 System robustness and reliability through protection features	10
5.5 Clamper circuit	10
5.6 PCB design tips.....	10
5.7 EMI reduction tips	11
6 PCB layout	12

22 W auxiliary power supply for indoor air-conditioner using ICE5AR2280CZ



Table of contents

6.1	Top side	12
6.2	Bottom side	12
7	Bill of materials.....	13
8	Transformer specification	15
9	Measurement data and graphs.....	16
9.1	Efficiency curve.....	18
9.2	Standby power	19
9.3	Line and load regulation (+12 V output)	19
9.4	Maximum input power	20
9.5	ESD immunity (EN 61000-4-2).....	20
9.6	Lightning surge immunity (EN 61000-4-5).....	20
9.7	Conducted emissions (EN 55022 class B)	21
9.8	Thermal measurement	22
9.9	+18 V rail line and load regulation (15 V LDO input).....	23
10	Waveforms and oscilloscope plots.....	24
10.1	Start-up at full load	24
10.2	Soft-start at full load	24
10.3	Drain and CS voltage at full load	25
10.4	Frequency jittering.....	25
10.5	Load-transient response.....	26
10.6	Output ripple voltage at full load	26
10.7	Output ripple voltage at ABM.....	27
10.8	Entering ABM	27
10.9	During ABM	28
10.10	Leaving ABM	28
10.11	V _{CC} OV/UV protection	29
10.12	Overload protection	29
10.13	Line overvoltage protection.....	30
11	Appendix A: Transformer design and spreadsheet [3]	31
12	Appendix B: WE transformer specification	40
13	References	41
	Revision history.....	42

System introduction

1 System introduction

With the growing household trend for internet-connected devices, the new generation of home appliances such as air-conditioners are equipped with advanced features such as wireless control and monitoring capability, smart sensors and touch screen display. These can transform a static product into an interactive and intelligent home appliance, capable of adapting to the smart-home theme. Infineon has introduced the latest fifth-generation FF CoolSET™ to address this need in an efficient and cost-effective manner.

An auxiliary SMPS is needed to power the various modules and sensors, which typically operate from a stable DC voltage source. The Infineon CoolSET™ (as shown in **Figure 1**) forms the heart of the system, providing the necessary protection and AC-DC conversion from the mains to multiple regulated DC voltages to power the various blocks.

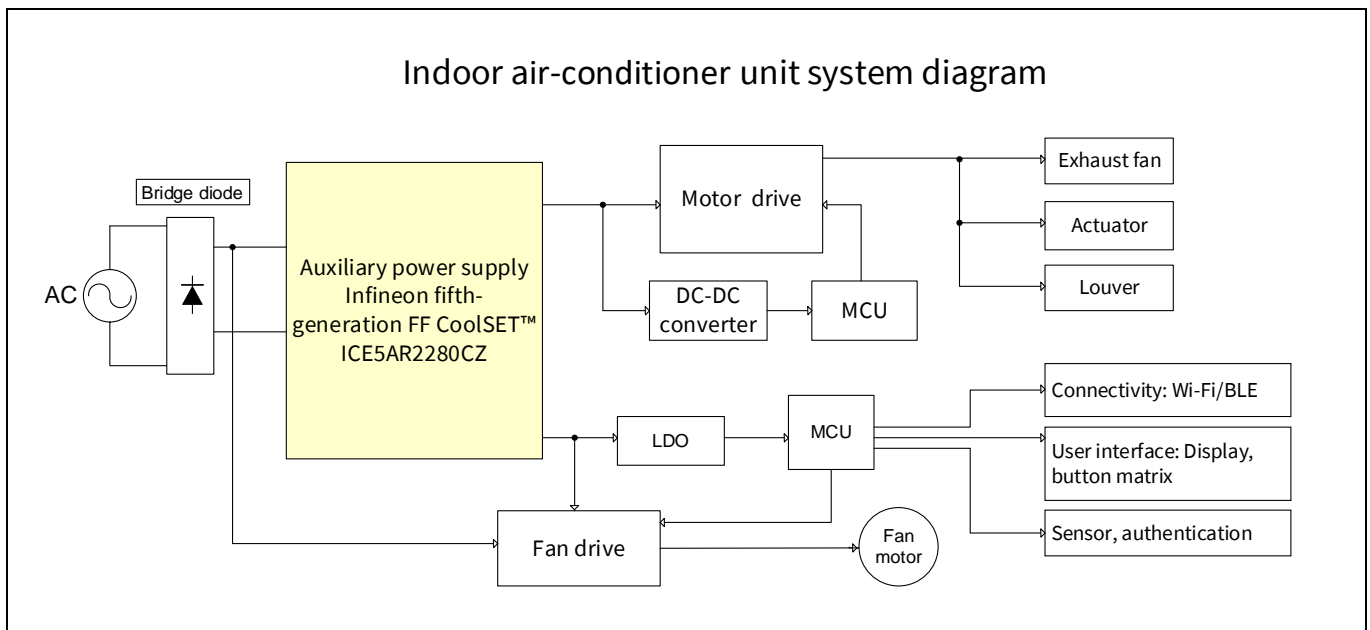

Figure 1 Simplified indoor air-conditioner system diagram

Table 1 lists the system requirements for auxiliary power supply for an indoor air-conditioner unit, and the corresponding Infineon solution is shown in the right-hand column.

Table 1 System requirements and Infineon solutions

	System requirement for indoor air-conditioner unit power supply	Infineon solution – ICE5AR2280CZ
1	High efficiency under light load and low standby power	Digital frequency reduction and active burst mode (ABM)
2	Robust system and protection features	Comprehensive CoolSET™ protection feature in DIP-7 package
3	Auto-restart protection scheme to minimize interruption to enhance end-user experience	All protections are in auto-restart

1.1 High efficiency under light load and low standby power

For indoor air-conditioner operation, the power requirement fluctuates according to various use cases. In most cases where room temperature is already stabilized, the indoor and outdoor air-conditioner units operate in an idle state, in which the loading toward the auxiliary power supply is low. It is crucial that the auxiliary power

System introduction

supply operates as efficiently as possible, because it will be in this particular state for most of the period. Under light-load conditions, losses incurred in the power switch are usually dominated by the switching operation. The choice of switching scheme and frequency play a crucial role in ensuring high conversion efficiency.

In this reference design, ICE5AR2280CZ was primarily chosen due to its frequency reduction switching scheme. Compared with a traditional FF flyback, the CoolSET™ reduces its switching frequency from medium to light load, thereby minimizing switching losses. Therefore, an efficiency of more than 80 percent is achievable under 25 percent loading conditions at nominal input voltages.

1.2 Simplified circuitry with good integration of power and protection features

To relieve the designer of the complexity of PCB layout and circuit design, the CoolSET™ is a highly integrated device with both a controller and a HV MOSFET integrated into a single, space-saving DIP-7 package. These certainly help the designer to reduce component count as well as simplifying the layout into a simple PCB design for ease of manufacturing, using the traditional cost-effective wave-soldering process.

1.3 Auto-restart protection scheme to minimize interruption to enhance end-user experience

For a residential air-conditioner unit, it would be annoying to both the end-user and the manufacturer if the system were to halt and latch after protection. Accessibility of the input AC plug may also be difficult; therefore, to minimize interruption, the CoolSET™ implements auto-restart mode for all abnormal protections.

22 W auxiliary power supply for indoor air-conditioner using ICE5AR2280CZ



Reference board design

2 Reference board design

This document provides complete design details including specifications, schematics, bill of materials (BOM), PCB layout and transformer design. Performance results pertaining to line/load regulation, efficiency, transient load, thermal conditions, conducted EMI scans and so on are also included.

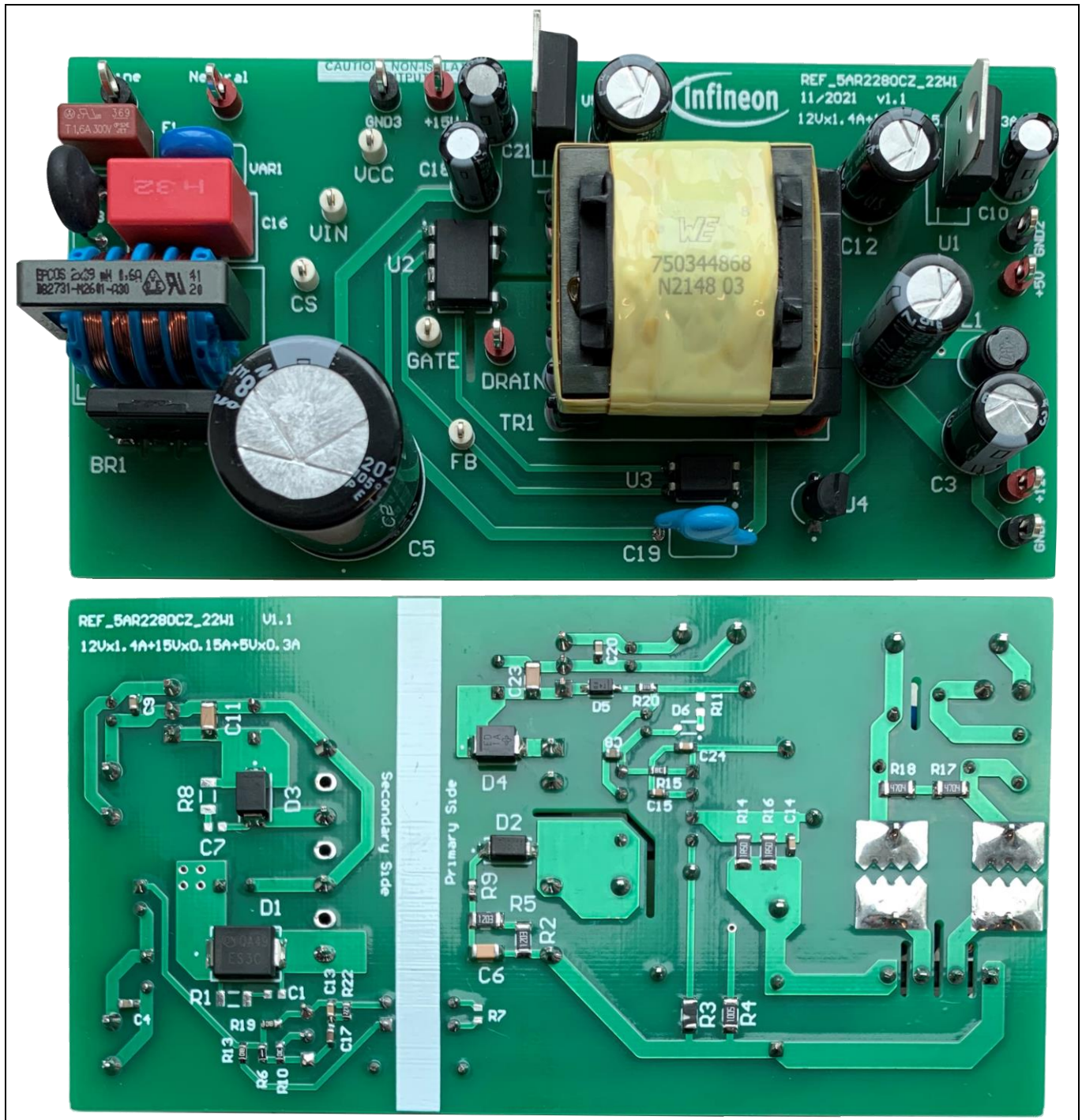

Figure 2 REF_5AR2280CZ_22W1

22 W auxiliary power supply for indoor air-conditioner using ICE5AR2280CZ



Power supply specifications

3 Power supply specifications

The table below shows the minimum acceptable performance of the design at 25°C ambient temperature. Actual performance is listed in the measurements section.

Table 2 Specifications of REF_5AR2280CZ_22W1

Description	Symbol	Min.	Typ.	Max.	Units	Comments
Input						
Voltage	V_{IN}	85	–	264	V AC	2 wires (no P.E.) LDOs not mounted
Frequency	f_{LINE}	47	50/60	64	Hz	
No-load input power	P_{stby_NL}	–	–	75	mW	
Output						
Output voltage 1	V_{O1}	–	12	–	V	± 1 percent
Output current 1	I_{O1}	5	–	1400	mA	
Output voltage ripple 1	$V_{RIPPLE1}$	–	–	150	mV	
Output voltage 2	V_{O2}	–	5	–	V	± 1 percent
Output current 2	I_{O2}	5	–	300	mA	
Output voltage ripple 2	$V_{RIPPLE2}$	–	–	75	mV	
Output voltage 3	V_{O3}	–	15	–	V	± 1 percent
Output current 3	I_{O3}	5	–	150	mA	
Output voltage ripple 3	$V_{RIPPLE3}$	–	–	100	mV	
Output power	P_{OUT_Nom}	–	20.55	–	W	LDO output Full load on other outputs
Overcurrent protection (+12 V)	I_{OCP}	–	1.7	–	A	
Start-up time	t_{start_up}	–	–	250	ms	
Efficiency						
Maximum load	η	75	–	–	%	115 V AC/230 V AC
Average efficiency	η_{avg}	75	–	–	%	
Maximum load (single output)	η_s	83	–	–	%	
Average efficiency (single output)	η_{avg_s}	83	–	–	%	
Environmental						
Conducted EMI			6		dB	Margin, CISPR 22 class B EN 61000-4-2 EN 61000-4-5
ESD						
Contact discharge			±6		kV	
Air discharge			±8		kV	
Surge immunity						
Differential mode			±2		kV	
Common mode			±4		kV	
PCBA dimension			110 x 57 x 30		mm ³	L x W x H

4 Circuit diagram

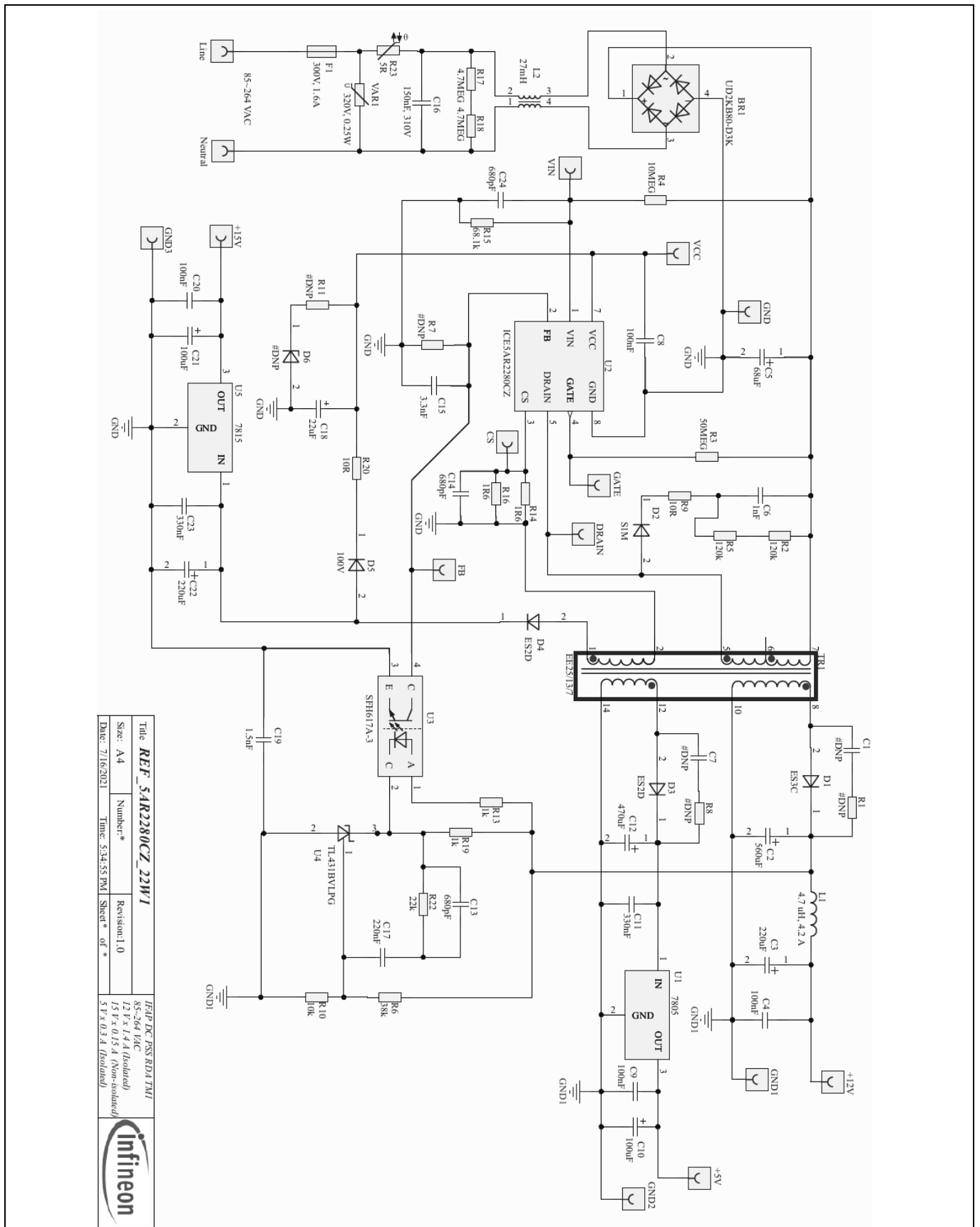

Figure 3 Schematic of REF_5AR2280CZ_22W1

Circuit description

5 Circuit description

In this section, the design circuit for the SMPS unit will be briefly described by the different functional blocks. For details of the design procedure and component selection for the flyback circuitry please refer to the IC design guide [2] and calculation tool [3].

5.1 EMI filtering and line rectification

The input of the power supply unit is taken from the AC power grid, which is in the range of 85 V AC ~ 264 V AC. The fuse F1 is directly connected to the input line to protect the system in case of excess current entering the system circuit due to any fault. Following is the varistor VAR, which is connected across the input to absorb excess energy during line-surge transient. The X-capacitor C16 and common-mode choke (CMC) L2 reduce the EMI noise. R17 and R18 serve as the X-capacitor discharge resistor. The bridge rectifier BR1 rectifies the AC input into DC voltage, filtered by the bulk capacitor C5.

5.2 Flyback converter power stage

The flyback converter power stage consists of transformer TR1, CoolSET™, secondary rectification diodes D1, D3 and D4, secondary output capacitors C2, C12 and C22 and output filter inductor L1.

When the primary HV MOSFET turns on, energy is stored in the transformer. When it turns off, the stored energy is discharged to the output capacitors and into the output load.

Secondary winding is sandwiched between two layers of primary winding to reduce leakage inductance. This improves efficiency and reduces voltage spikes.

For the output rectification, lower forward voltage and ultra-fast recovery diodes can improve efficiency. Capacitor C2, C12 stores the energy needed during output load jumps. LC filter L1/C3 reduces the high-frequency ripple voltage.

The +15 V output is from the 15 V low dropout (LDO) regulator (U5) with an input of +18 V, which also supplies V_{CC} . The +5 V output is from the 5 V LDO regulator (U1) with an input of +8 V. As such, these two outputs would not be affected by cross-regulation. However, their inputs should be maintained within the operating range of the LDO.

5.3 Control of flyback converter through fifth-generation FF CoolSET™ ICE5AR2280CZ

5.3.1 Current sensing

The ICE5AR2280CZ is a current mode controller. The primary peak current is controlled cycle-by-cycle through the current sense (CS) resistors R14 and R16 in the CS pin (pin 4). Transformer saturation can be avoided through peak current limitation (PCL); therefore, the system is more protected and reliable.

5.3.2 Feedback and compensation network

Resistor dividers R6 and R10 are used to sense the V_{OUT} and send the reference voltage to the feedback (FB) pin (pin 2) via error amplifier TL431 (U4) and optocoupler (U3). A Type II compensation network C13, C17 and R22 is implemented to stabilize the system.

The FB pin of ICE5AR2280CZ is a multifunction pin, which is used to select the entry burst power level (there are three levels available) through the resistor at the FB pin (R7) and also the burst-on/burst-off sense input during ABM.

Circuit description

5.4 Unique features of the fifth-generation FF CoolSET™ ICE5AR2280CZ

5.4.1 Fast self-start-up and sustaining of V_{CC}

The IC uses a cascode structure to fast-charge the V_{CC} capacitor. Pull-up resistor R3 connected to the GATE pin (pin 4) is used to initiate the start-up phase. At first, I_{VCC_Charge1} is used to charge the V_{CC} capacitor from 0 V to V_{CC_SCP}. This is a protection which reduces the power dissipation of the power MOSFET during V_{CC} short-to-GND condition. Thereafter, a much higher charging current of I_{VCC_Charge2} will charge the V_{CC} capacitor until the V_{CC_ON} is reached.

After start-up, the IC V_{CC} supply is usually sustained by the auxiliary winding of the transformer, which needs to support the V_{CC} to be above undervoltage lockout (UVLO) voltage (10 V typ.). In this reference board, the V_{CC} supply is tapped from the +18 V winding.

5.4.2 CCM, DCM operation with frequency reduction

ICE5AR2280CZ can be operated in either discontinuous conduction mode (DCM) or continuous conduction mode (CCM) with frequency-reduction features. This reference board is designed to operate in DCM at operating input voltage and load conditions. When the system is operating at high output load, the controller will switch at 100 kHz FF. In order to achieve a better efficiency between light load and medium load, frequency reduction is implemented as a function of V_{FB}, as shown in Figure 4. Switching frequency will not reduce further once the minimum switching frequency of 43 kHz is reached.

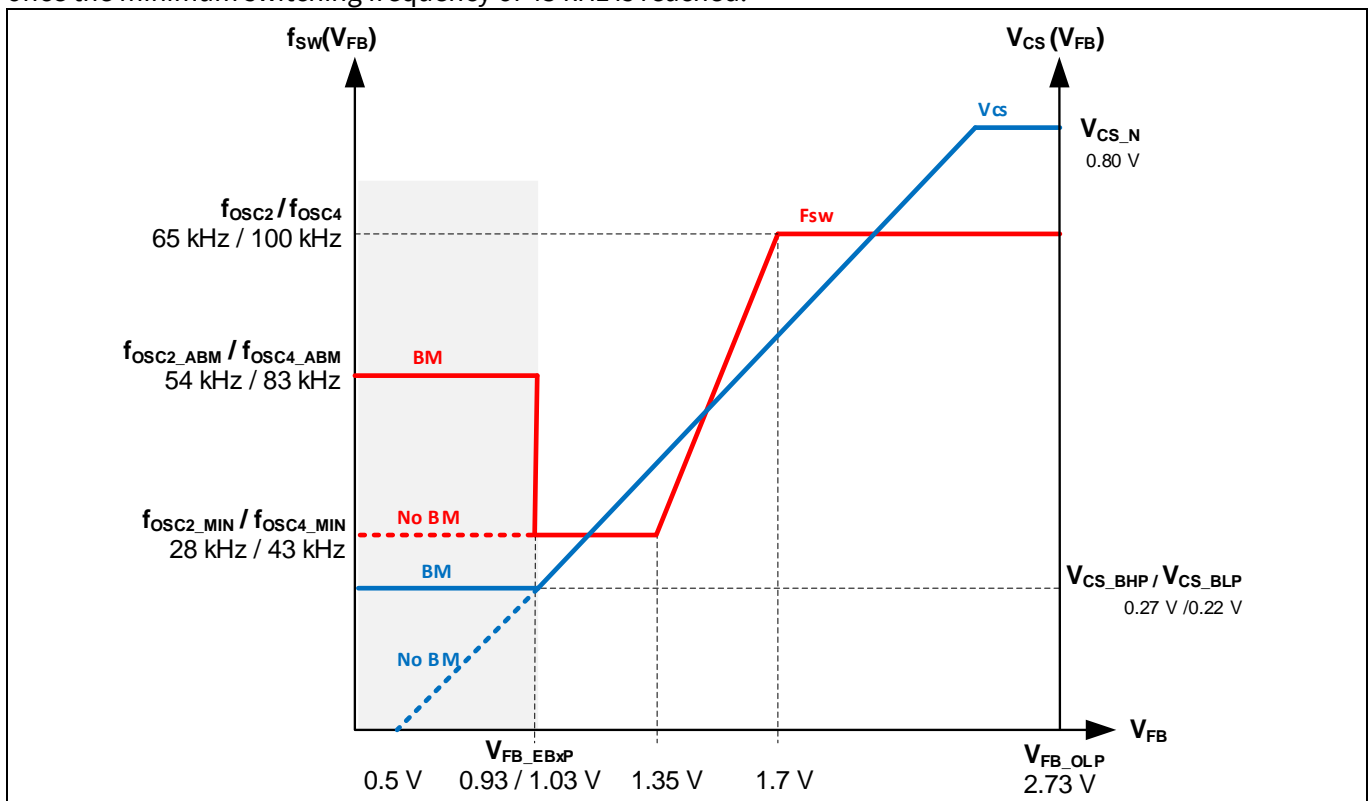

Figure 4 Frequency-reduction curve

5.4.3 Frequency jittering with modulated gate drive

The ICE5AR2280CZ has a frequency jittering feature with modulated gate drive to reduce the EMI noise. The jitter frequency is internally set at 100 kHz (±4 percent), and the jitter period is 4 ms.

Circuit description

5.4.4 System robustness and reliability through protection features

Protection is one of the major factors in determining whether the system is safe and robust – therefore sufficient protection is necessary. ICE5AR2280CZ provides comprehensive protection to ensure the system is operating safely. This includes input line overvoltage (OV), V_{CC} OV and undervoltage (UV), overload, overtemperature and V_{CC} short-to-GND. When those faults are found, the system will enter protection mode. Once the fault is removed, the system resumes normal operation. A list of protections and the failure conditions is shown in the table below.

Table 3 Protection functions of ICE5AR2280CZ

Protection function	Failure condition	Protection mode
Line OV	V_{VIN} greater than V_{VIN_LOVP}	Non-switch auto-restart
V_{CC} OV	V_{VCC} greater than V_{VCC_OVP}	Odd-skip auto-restart
V_{CC} UV	V_{VCC} less than V_{VCCoff}	Auto-restart
Overload	V_{FB} greater than V_{FB_OLP} and lasts for $t_{FB_OLP_B}$	Odd-skip auto-restart
Overtemperature	T_J greater than 140°C (40°C hysteresis)	Non-switch auto-restart
V_{CC} short-to-GND ($V_{VCC} = 0$ V, start-up = 50 MΩ and $V_{DRAIN} = 90$ V)	V_{VCC} less than V_{CC_SCP} , $I_{VCC_Charge1} \approx -0.2$ mA	Cannot start up

5.5 Clamper circuit

A clamper network (D2, C6, R2, R5, R9) is used to reduce the switching voltage spikes across the DRAIN pin of the integrated HV MOSFET of the CoolSET™, which are generated by the leakage inductance of the transformer TR1. This is a dissipative circuit; therefore, R2 and R5 and C6 need to be fine-tuned depending on the voltage derating factor and efficiency requirement.

5.6 PCB design tips

For a good PCB design layout, there are several points to note.

- The switching power loop needs to be as small as possible (see [Figure 5](#)). There are four power loops in the reference design; one on the HV side and three on the output side. The HV side loop starts from the bulk capacitor (C5) positive terminal, primary transformer winding (pin 7 and pin 5 of TR1), CoolSET™, CS resistors and back to the C5 negative terminal. The first output side loop (12 V output) starts at the transformer winding (pin 8 of TR1), output diode D1, output capacitor C2 and back to pin 10 of TR1. The second output side loop (8 V output) starts at the transformer winding (pin 12 of TR1), output diode D3, output capacitor C12 and back to pin 14 of TR1. The third output side loop (18 V output) starts at the transformer winding (pin 1 of TR1), output diode D4, output capacitor C18 and back to pin 2 of TR1.

Circuit description

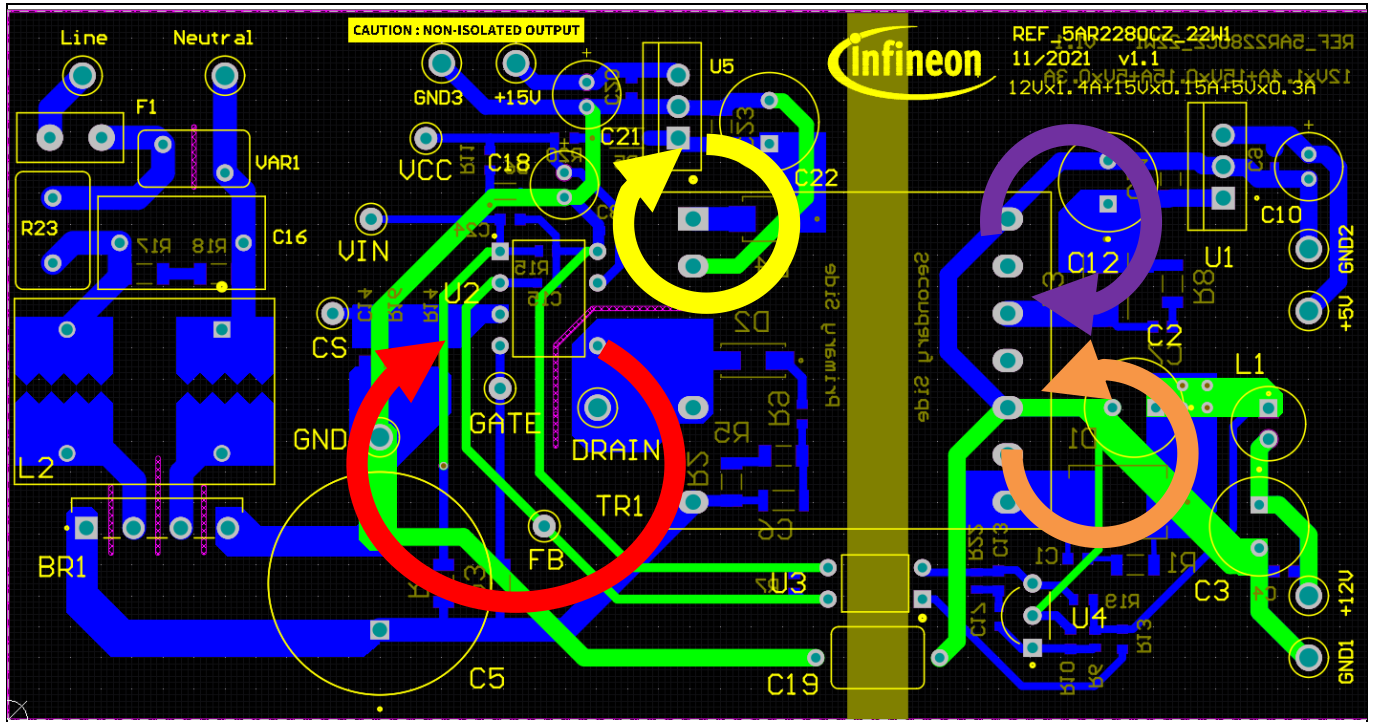

Figure 5 PCB layout tips

- Star-ground connection should be used to reduce high-frequency (HF) noise coupling that can affect the functional operation. The ground of the small-signal components should connect directly to the IC ground (pin 8 of U2).
- Separating the HV components and LV components, e.g. clamper circuit, main switching circuit; this can help to reduce spark-over chance of the high energy surge during a lightning surge test.
- Make the PCB copper pour on the DRAIN pin of the MOSFET act as a heatsink.

5.7 EMI reduction tips

EMI compliance is always a challenge for the power supply designer. There are several critical points to consider in order to achieve a satisfactory EMI performance.

- A proper transformer design can significantly reduce EMI. Low leakage inductance can incur a low switching spike and HF noise. Interlaced winding technique is the most common practice to reduce leakage inductance. Winding shield, core shield and whole transformer shield are also some of the techniques used to reduce EMI.
- Input CMC and X-capacitor greatly reduce EMI, but this is costly and impractical especially for low-power applications.
- Short-switching power-loop design in the PCB (as described in section 5.6) can reduce radiated EMI due to the antenna effect.
- An output diode snubber circuit can reduce HF noise.
- Ferrite beads can reduce HF noise, especially on critical nodes such as the DRAIN pin, clamper diode and output diode terminals. There is no ferrite bead used in this design, as this can reduce the efficiency due to additional losses, especially on high-current terminals.

PCB layout

6 PCB layout

6.1 Top side

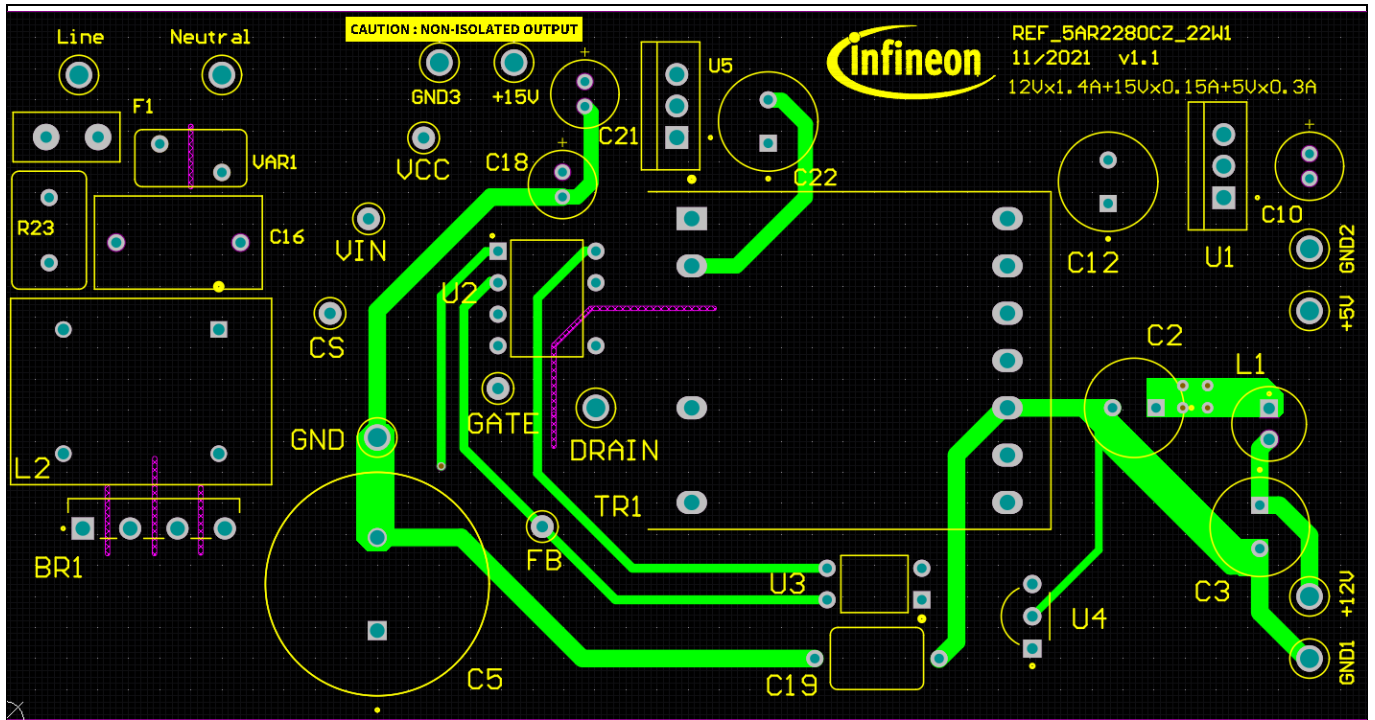

Figure 6 Top-side copper and component legend

6.2 Bottom side

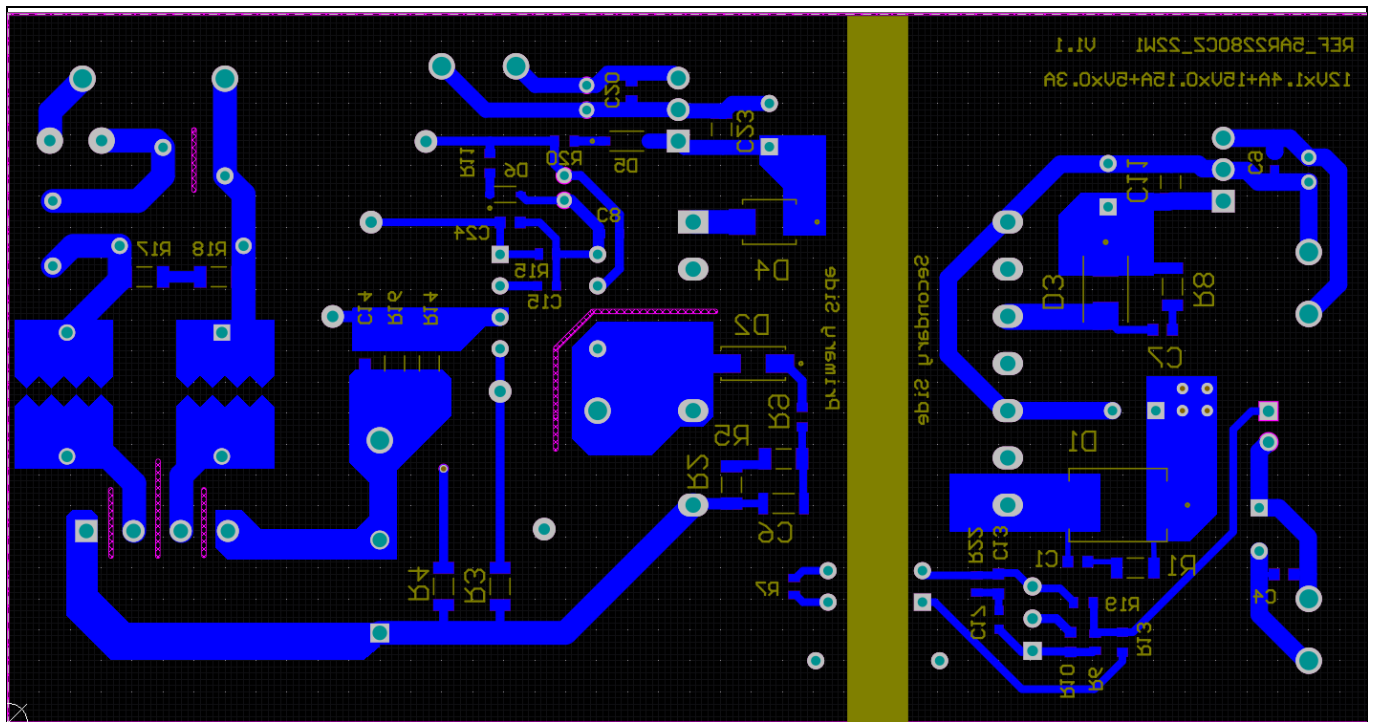

Figure 7 Bottom-side copper and component legend

22 W auxiliary power supply for indoor air-conditioner using ICE5AR2280CZ



Bill of materials

7 Bill of materials

Table 4 BOM

No.	Designator	Description	Manufacturer	Part number	Quantity
1	BR1	Bridge diode 800 V 2 A	Shindengen	UD2KB80-7000	1
2	C2	Aluminum capacitor 560 μ F 20% 25 V radial	Rubycon	25ZLJ560M8X20	1
3	C3, C22	Aluminum capacitor 220 μ F 20% 35 V radial			2
4	C4, C8, C9, C20	Ceramic capacitor 0.1 μ F 50 V X7R 0603			4
5	C5	Aluminum capacitor 68 μ F 20% 450 V radial	Rubycon	450BXW68MEFR18X25	1
6	C6	Ceramic capacitor 1206 1nF 500 V X7R 10% FL	AVX	12067C102KAT2A	1
7	C10, C21	Aluminum capacitor 100 μ F 20% 25 V radial	Rubycon	25PX100MEFC5X11	2
8	C11, C23	Ceramic capacitor 0.33 μ F 50 V X7R 1206			2
9	C12	Aluminum capacitor 470 μ F 20% 16 V TH	Rubycon	16ZLJ470M8X11.5	1
10	C13, C14, C24	Ceramic capacitor 0603 680 pF 50 V X7R 10%			3
11	C15	Ceramic capacitor 0603 3.3 nF 50 V X7R 10%			1
12	C16	Film capacitor 0.15 μ F 10% 310 V AC radial	Würth Elektronik	890334023025	1
13	C17	Ceramic capacitor 0.22 μ F 50 V X7R 0603			1
14	C18	Aluminum capacitor 22 μ F 20% 35 V radial	Nichicon	UVR1V220MDD	1
15	C19	Ceramic capacitor 1500 pF 250 V radial	Murata	DE1E3KX152MA4BN01F	1
16	D1	General-purpose diode 150 V 3 A SMC		ES3C	1
17	D2	General-purpose diode 1 kV 1 A SMA		S1M	1
18	D3, D4	General-purpose diode 150 V 2 A DO214AA		ES2C	2
19	D5	General-purpose diode 100 V 150 mA SOD-123	Diodes Inc.	BAV16W-7-F	1
20	F1	Time-lag fuse 300 V 1.6 A	Littelfuse	36911600000	1
21	L1	Inductor WE-TI size 5075 4.7 μ H 4.2 A	Würth Elektronik	7447462047	1
22	L2	CMC 39 mH 600 mA 2LN TH	TDK	B82731M2601A030	1
23	R2, R5	SMD resistor 120 k Ω 1% 1/4 W 1206			2
24	R3	SMD resistor 50 m Ω 1% 1206	Vishay	CRHA1206AF50M0FKEF	1
25	R4	SMD resistor 10 m Ω 1% 1206	Vishay	RCV120610M0FKEA	1
26	R6	Resistor 38 k Ω 1% 1/10 W 0603			1
27	R9, R20	SMD resistor 27 Ω 1% 1/10 W 0603			2
28	R10	Resistor 10 k Ω 1% 1/10 W 0603			1
29	R14, R16	SMD resistor 1.5 Ω 1% 1/4 W 1206			2
30	R15	SMD resistor 68.1 k Ω 1% 1/10 W 0603			1
31	R17, R18	SMD resistor 4.7 m Ω 1% 1/4 W 1206			2
32	R13, R19	SMD resistor 1 k Ω 1% 1/8 W 0603			2
33	R22	Resistor 22 k Ω 1% 1/10 W 0603			1
34	R23	ICL 5 Ω 20% 4.2 A 9.5 mm	TDK	B57235S0509M000	1
35	TR1	Transformer EE25/13/7	Würth Elektronik	750344864 (REV.04)	1

22 W auxiliary power supply for indoor air-conditioner using ICE5AR2280CZ



Bill of materials

36	U1	L7805	STMicroelectronics	L7805ABV	1
37	U2	FF 800 V CoolSET™	Infineon	ICE5AR2280CZ	1
38	U3	Optocoupler 5300 V _{RMS}	Vishay	SFH617A-3	1
39	U4	IC V _{REF} Shunt 36 V 0.4% TO92-3		TL431BVLPG	1
40	U5	L7815	STMicroelectronics	L7815ABV	1
41	VAR1	S07K320E2 320 V AC 10%	Epcos	B72207S2321K101	1
42	+15 V, +5 V, +12 V, DRAIN, neutral	Test point THT, red	Keystone	5010	5
43	GND, GND1, GND2, GND3, line	Test point THT, black	Keystone	5011	5
44	CS, FB, GATE, V _{CC} , V _{IN}	Test point THT, white	Keystone	5002	5

Transformer specification

8 Transformer specification

Refer to Appendix A for transformer design and Appendix B for WE transformer specification.

Core name and material: EE25/13/7, TP4A (TDG)

Primary inductance: $L_p = 420 \mu\text{H}$ (± 10 percent), measured between pin 5 and pin 7

Manufacturer and part number: Würth Elektronik Midcom (750344868) Rev. 04

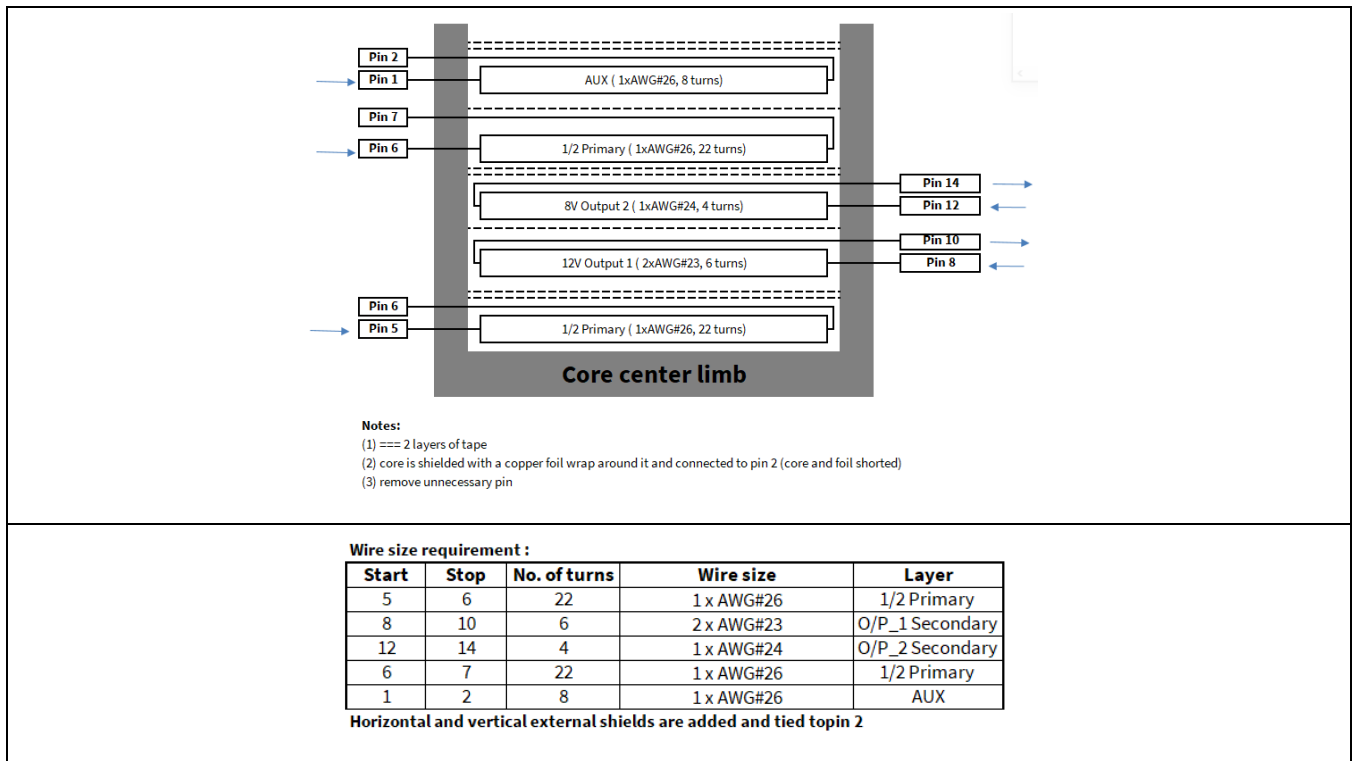

Figure 8 Transformer structure

9 Measurement data and graphs

Table 5 Electrical measurements

Input (V AC/Hz)	P _{IN} (W)	V _{O1} (V)	I _{O1} (A)	V _{O2} (V)	I _{O2} (A)	V _{O3} (V)	I _{O3} (A)	P _{OUT} (W)	Efficiency (%)	Average efficiency (%)	OLP P _{IN} (W)	OLP I _{O1} (A)
85 V AC/ 60 Hz	0.303	12.020	0.000	15.147	0.004	5.085	0.006	0.091	/	/	31.65	1.69
	6.564	12.010	0.343	15.110	0.038	5.083	0.073	5.065	77.16	76.88		
	13.200	11.990	0.694	15.100	0.078	5.080	0.146	10.241	77.58			
	19.080	11.990	0.995	15.100	0.107	5.078	0.219	14.658	76.82			
	26.880	11.980	1.395	15.120	0.147	5.078	0.291	20.412	75.94			
115 V AC/ 60 Hz	0.315	12.020	0.000	15.120	0.004	5.083	0.006	0.091	/	/	33.75	1.71
	6.484	12.010	0.343	15.110	0.038	5.080	0.073	5.064	78.11	78.53		
	12.960	11.990	0.694	15.100	0.078	5.080	0.146	10.241	79.02			
	18.616	11.980	0.995	15.090	0.107	5.078	0.219	14.647	78.68			
	26.040	11.970	1.395	15.090	0.147	5.078	0.291	20.394	78.32			
230 V AC/ 50 Hz	0.330	12.020	0.000	15.130	0.004	5.083	0.006	0.091	/	/	30.79	1.77
	6.500	12.010	0.343	15.110	0.038	5.080	0.073	5.064	77.91	79.24		
	12.890	11.990	0.694	15.100	0.078	5.080	0.146	10.241	79.45			
	18.400	11.990	0.995	15.100	0.107	5.078	0.219	14.658	79.66			
	25.530	11.980	1.395	15.110	0.147	5.078	0.291	20.411	79.95			
264 V AC/ 50 Hz	0.340	12.020	0.000	15.120	0.004	5.083	0.006	0.091	/	/	31.31	1.79
	6.560	12.010	0.343	15.110	0.038	5.080	0.073	5.064	77.20	78.85		
	12.960	11.990	0.694	15.100	0.078	5.078	0.146	10.240	79.01			
	18.440	11.990	0.995	15.100	0.107	5.078	0.219	14.658	79.49			
	25.590	11.970	1.395	15.100	0.147	5.078	0.291	20.396	79.70			

Minimum load condition: 12 V/0 A, 5 V/5 mA, 15 V/5 mA

25 percent load condition: 12 V/0.35 A, 5 V/0.08 A, 15 V/0.04 A

50 percent load condition: 12 V/0.7 A, 5 V/0.15 A, 15 V/0.08 A

75 percent load condition: 12 V/1.05 A, 5 V/0.23 A, 15 V/0.11 A

100 percent load condition: 12 V/1.4 A, 5 V/0.3 A, 15 V/0.15 A

22 W auxiliary power supply for indoor air-conditioner using ICE5AR2280CZ



Measurement data and graphs

Table 6 Single-output efficiency data

Input (V AC/Hz)	P _{IN} (W)	V _{O1} (V)	I _{O1} (A)	P _{OUT} (W)	Efficiency (%)	Average efficiency (%)
85 V AC/ 60 Hz	0.041	12.000	0.000	0.000		81.34
	1.995	11.984	0.135	1.618	81.09	
	5.010	11.984	0.343	4.111	82.05	
	10.142	11.968	0.694	8.306	81.90	
	14.657	11.968	0.995	11.908	81.25	
	20.783	11.953	1.394	16.662	80.17	
115 V AC/ 60 Hz	0.045	12.000	0.000	0.000		82.56
	1.990	11.984	0.135	1.618	81.30	
	4.980	11.984	0.343	4.111	82.54	
	10.030	11.968	0.694	8.306	82.81	
	14.410	11.968	0.995	11.908	82.64	
	20.260	11.953	1.394	16.662	82.24	
230 V AC/ 50 Hz	0.055	12.000	0.000	0.000		82.65
	2.020	11.984	0.135	1.618	80.09	
	5.025	11.984	0.343	4.111	81.80	
	10.060	11.968	0.694	8.306	82.56	
	14.330	11.968	0.995	11.908	83.10	
	20.040	11.953	1.394	16.662	83.15	
264 V AC/ 50 Hz	0.058	12.000	0.000	0.000		82.35
	2.030	11.984	0.135	1.618	79.70	
	5.092	11.984	0.343	4.111	80.72	
	10.040	11.968	0.694	8.306	82.73	
	14.360	11.968	0.995	11.908	82.93	
	20.070	11.953	1.394	16.662	83.02	

Note: The single-output (+12 V) configuration efficiency measurement was done by removing two LDO outputs and adding Zener clamp circuit (R26 = 10 Ω, D6 = 22 V Zener); the actual board comes with LDO circuits. The overall circuit is not optimized for single-output configuration; the above efficiency data is for illustration only.

Measurement data and graphs

9.1 Efficiency curve

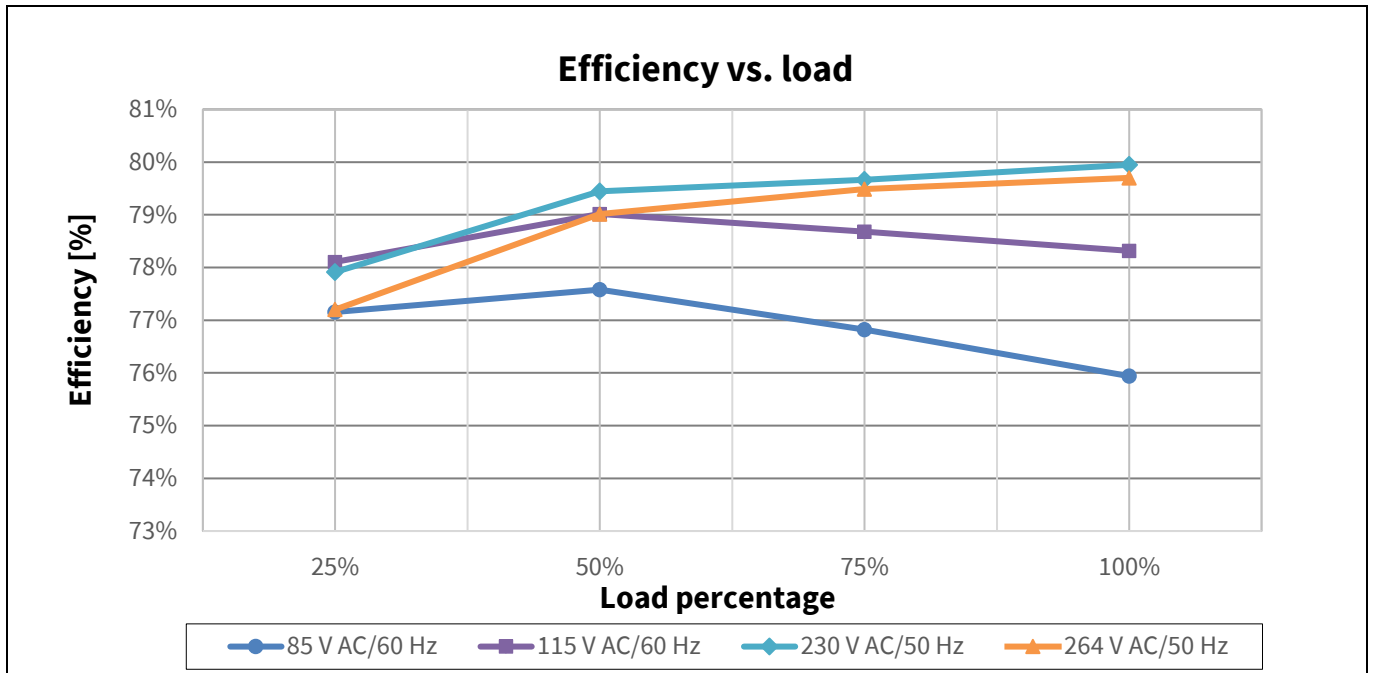

Figure 9 Efficiency vs. output load

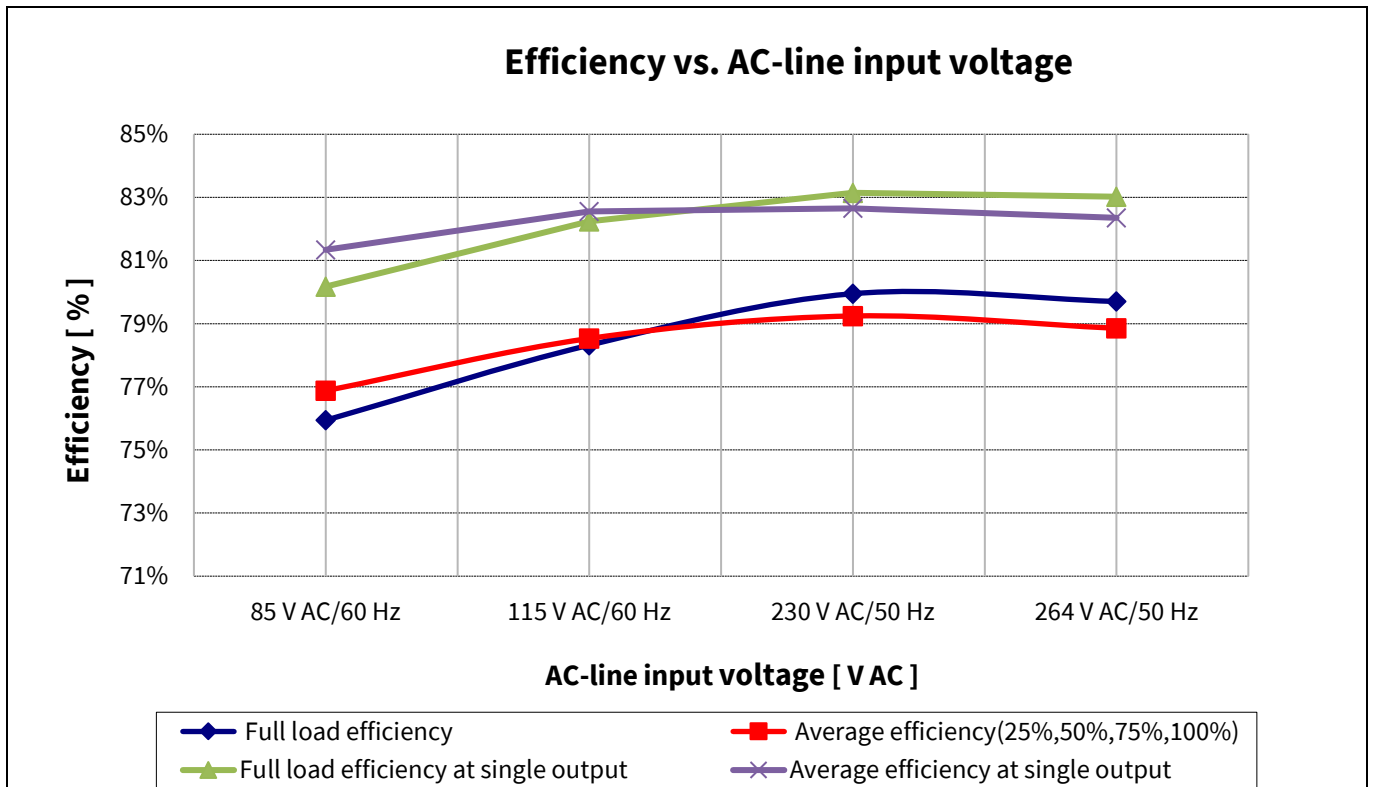

Figure 10 Efficiency vs. AC-line input voltage

9.2 Standby power

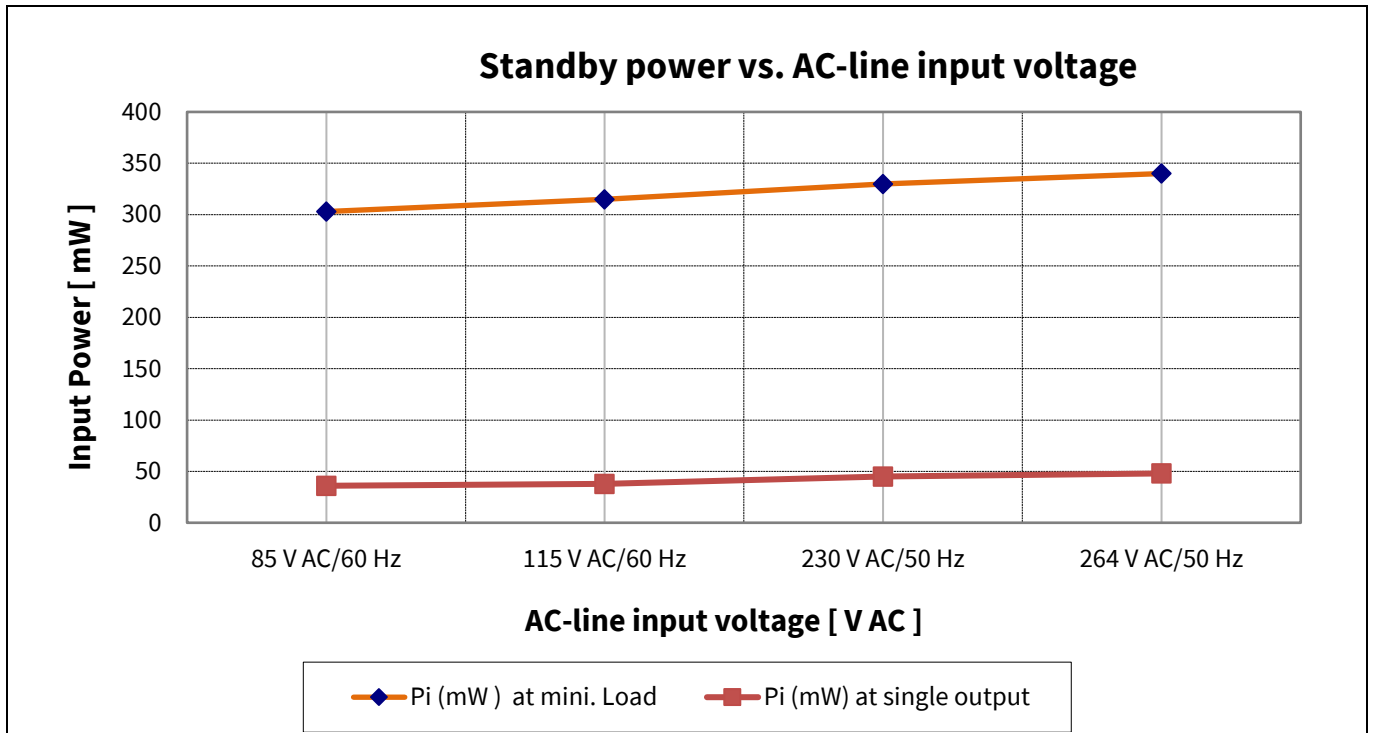

Figure 11 Standby power vs. AC-line input voltage

9.3 Line and load regulation (+12 V output)

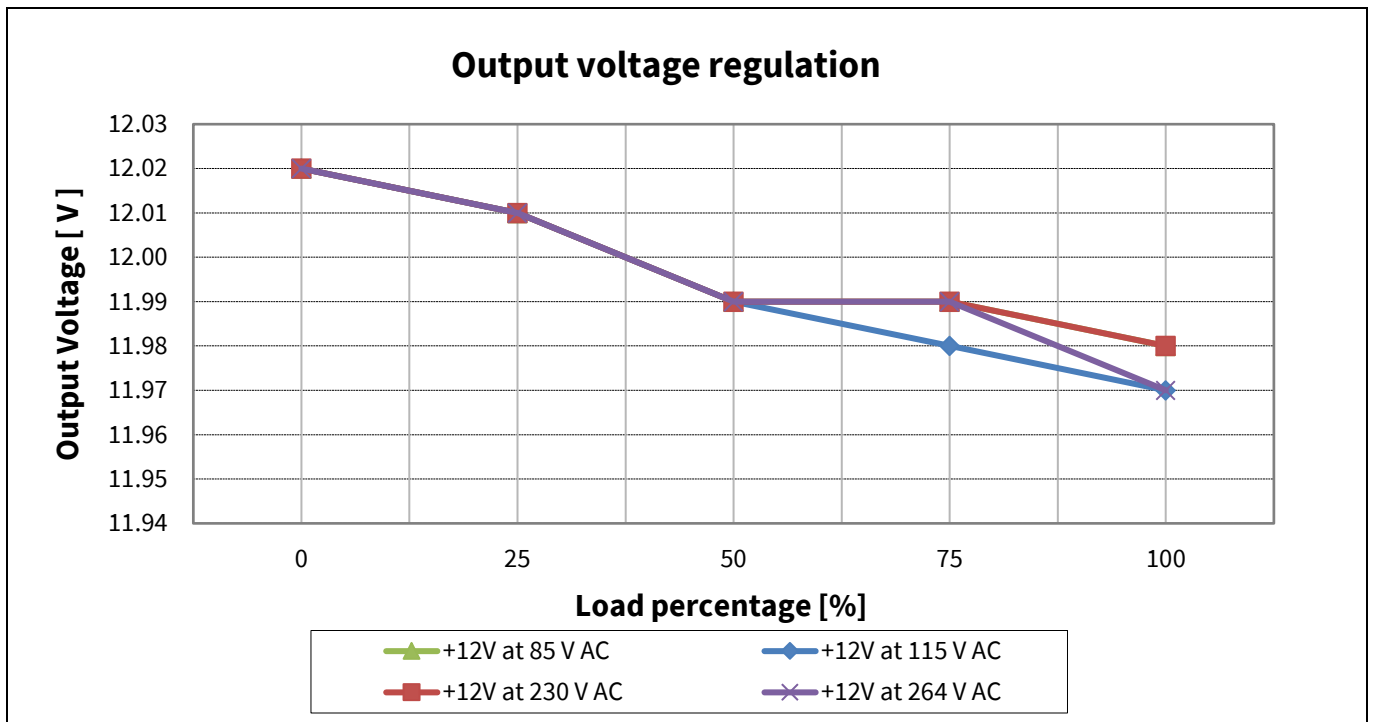

Figure 12 Line and load regulation (+12 V output)

9.4 Maximum input power

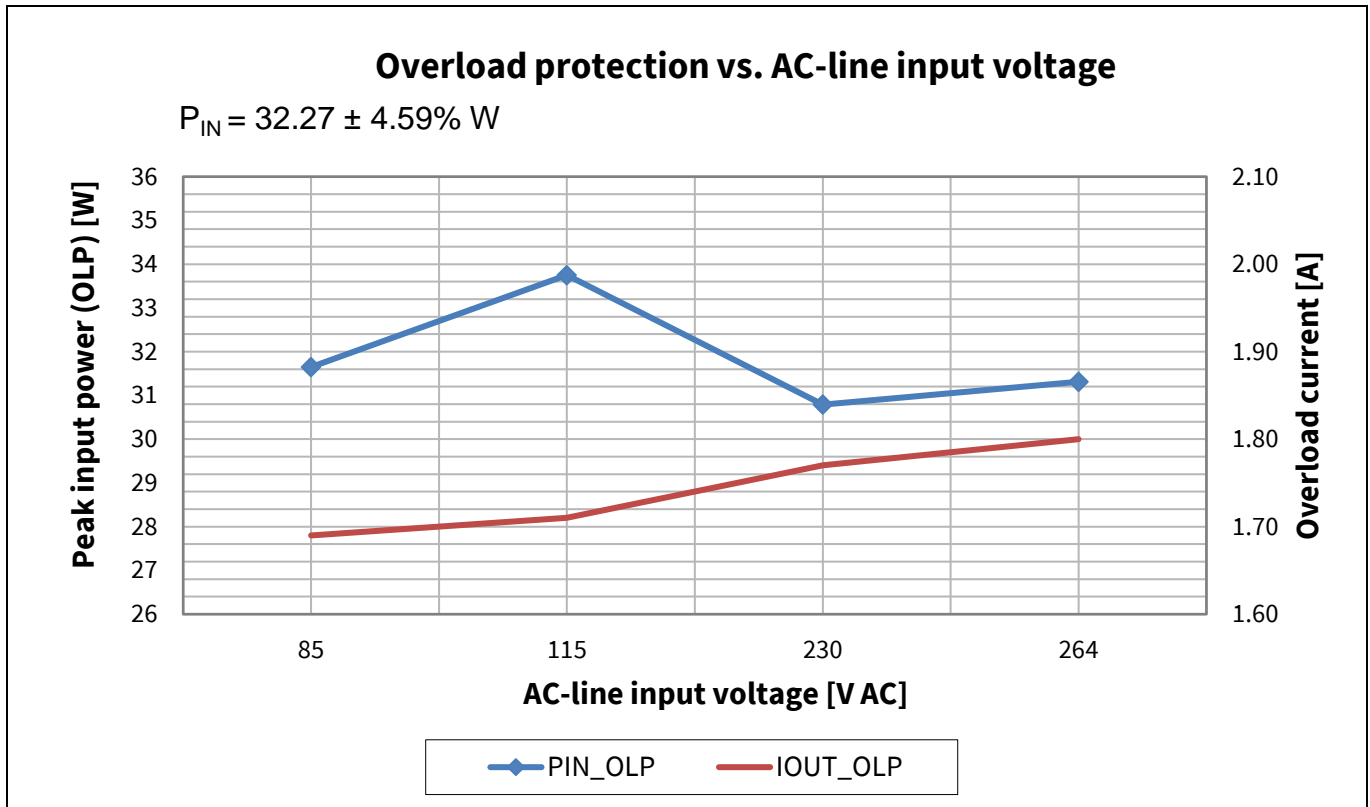

Figure 13 Maximum input power and output current (before overload protection) vs. AC-line input voltage

9.5 ESD immunity (EN 61000-4-2)

This system was subjected to ESD testing according to EN 61000-4-2 level 3 (± 6 kV contact and ± 8 kV air discharge). It was tested at full load (resistive load). A test failure was defined as non-recoverable.

Table 7 System ESD test result

Description	ESD test	Level	Number of strikes			Test result
			V _{O1}	V _{O2}	GND	
115/230 V AC, 22 W	Contact	± 6 kV	10	10	10	Pass
	Air	± 8 kV	10	10	10	Pass

9.6 Lightning surge immunity (EN 61000-4-5)

The reference board was subjected to a surge immunity test (± 2 kV DM and ± 4 kV CM) according to EN 61000-4-5. It was tested at full load (resistive load). A test failure was defined as non-recoverable.

Table 8 System lightning surge immunity test result

Description	Test	Level		Number of strikes				Test result
				0°	90°	180°	270°	
115/230 V AC	DM	± 2 kV	L → N	3	3	3	3	Pass
		± 4 kV	L → G	3	3	3	3	Pass
	CM	± 4 kV	N → G	3	3	3	3	Pass

Measurement data and graphs

9.7 Conducted emissions (EN 55022 class B)

The conducted EMI was measured by Schaffner (SMR4503) and followed the test standard of EN 55022 (CISPR 22) class B. The reference board was tested at full load (resistive load) at input voltage of 115 V AC and 230 V AC.

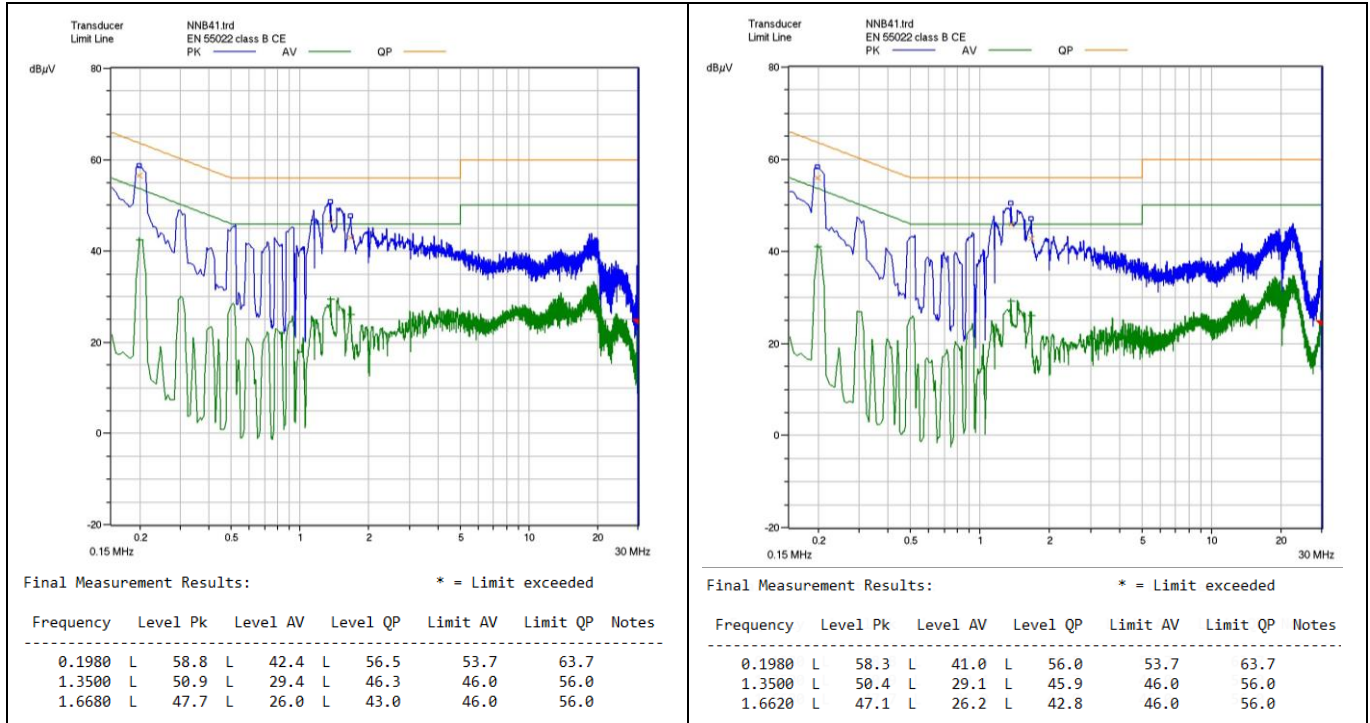

Figure 14 Conducted emissions at 115 V AC and full load on line (left) and neutral (right)

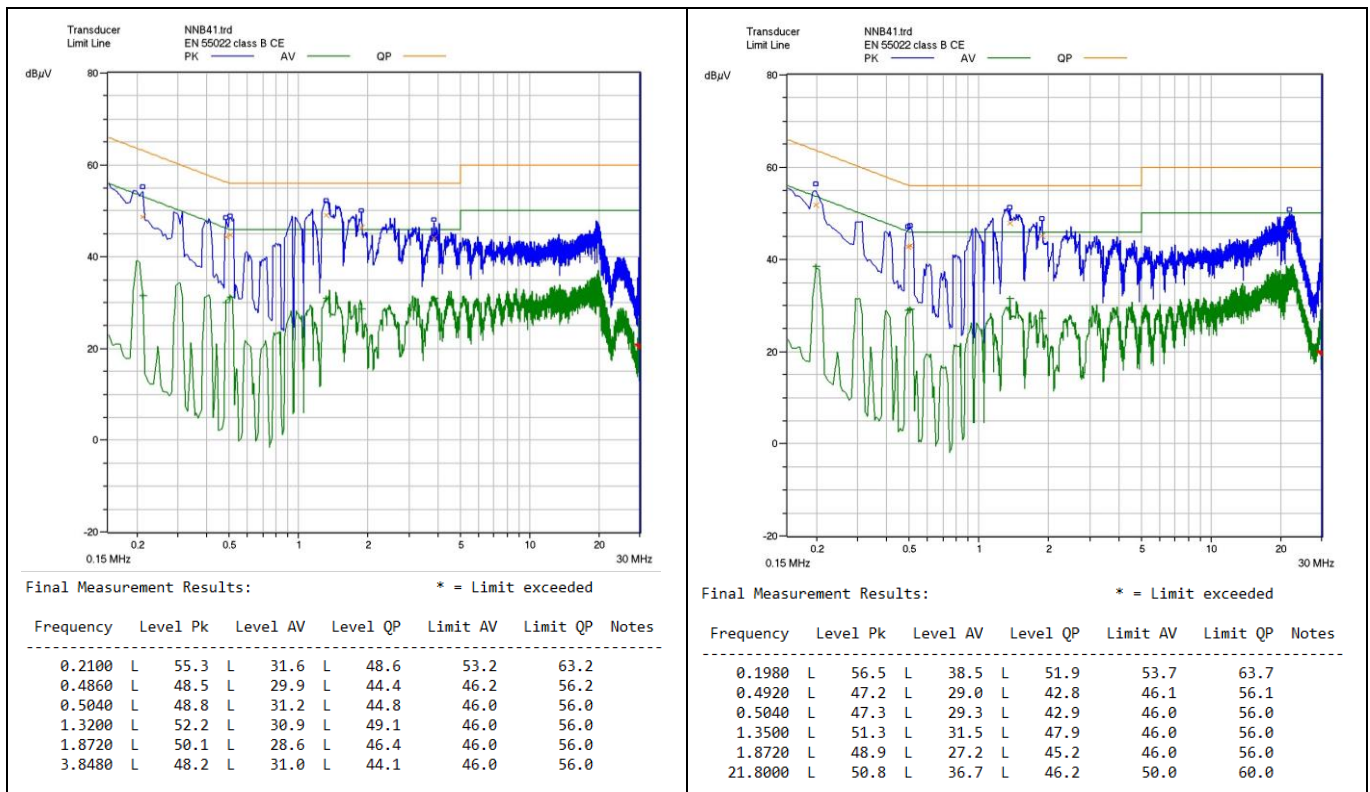

Figure 15 Conducted emissions at 230 V AC and full load on line (left) and neutral (right)

Measurement data and graphs

9.8 Thermal measurement

Thermal measurement was done by using an infrared thermography camera (FLIR-T62101) at an ambient temperature of 25°C taken after one hour running at full load. The temperature of the components was taken in an open-frame setup.

Table 9 Thermal measurement of components (open-frame)

No.	Components	Temperature at 85 V AC (°C)	Temperature at 264 V AC (°C)
1	U2 (ICE5AR2280CZ)	74.6	58.7
2	BR1 (bridge diode)	62.5	37.9
3	TR1 (transformer)	58.5	61.8
4	D1 (output 1 diode)	91.4	92.1
5	D3 (output 2 diode)	66.7	66.5
6	D4 (output 3 diode)	62.7	62.8

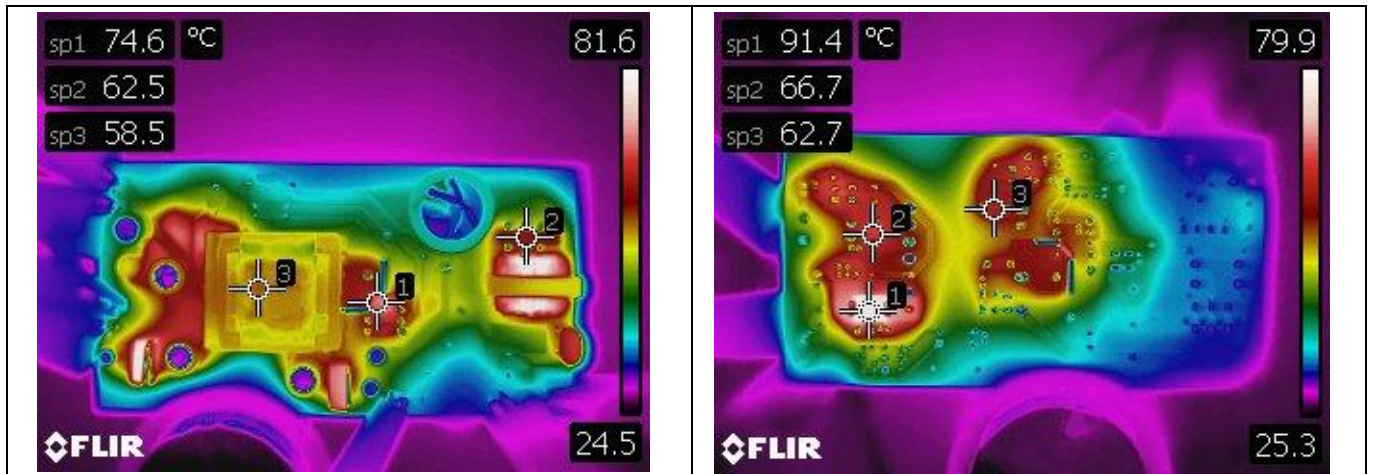

Figure 16 Top-side (left) and bottom-side (right) thermal image at 85 V AC input voltage

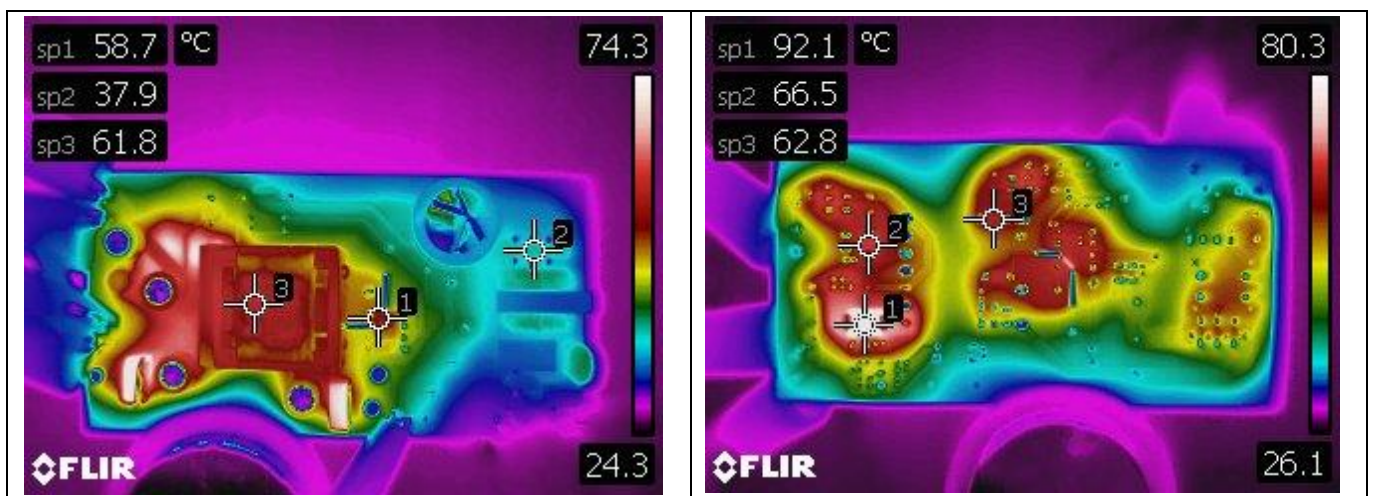

Figure 17 Top-side (left) and bottom-side (right) thermal image at 264 V AC input voltage

Measurement data and graphs

9.9 +18 V rail line and load regulation (15 V LDO input)

As the +15 V output via a 15 V LDO is derived from the +18 V rail from the transformer which is also shared by the CoolSET™ V_{CC}, there are several design goals to achieve during normal operating conditions:

- Avoid V_{CC} UVLO (10 V typ.)
- Avoid V_{CC} OVP (25.5 V typ.)
- Meet the specification of the LDO: (V_{OUT} + 2 V) ≤ V_{IN} ≤ 30 V

From the chart and table below, the +18 V rail is operating between 17.54 V and 25.38 V under different load combination and line conditions, which is well within the design objectives outlined above.

Table 10 +18 V rail line and load regulation

Conditions	12 V/0 A 5 V/0 A 15 V/0 A (V)	12 V/0 mA 5 V/5 mA 15 V/5 mA (V)	12 V/1.4 A 5 V/5 mA 15 V/5 mA (V)	12 V/1.4 A 5 V/0.3 A 15 V/0.15 A (V)
85 V AC/60 Hz	17.98	17.58	24.43	19.14
115 V AC/60 Hz	17.96	17.56	24.58	19.15
230 V AC/50 Hz	17.94	17.54	25.28	19.23
264 V AC/50 Hz	17.89	17.46	25.38	19.24

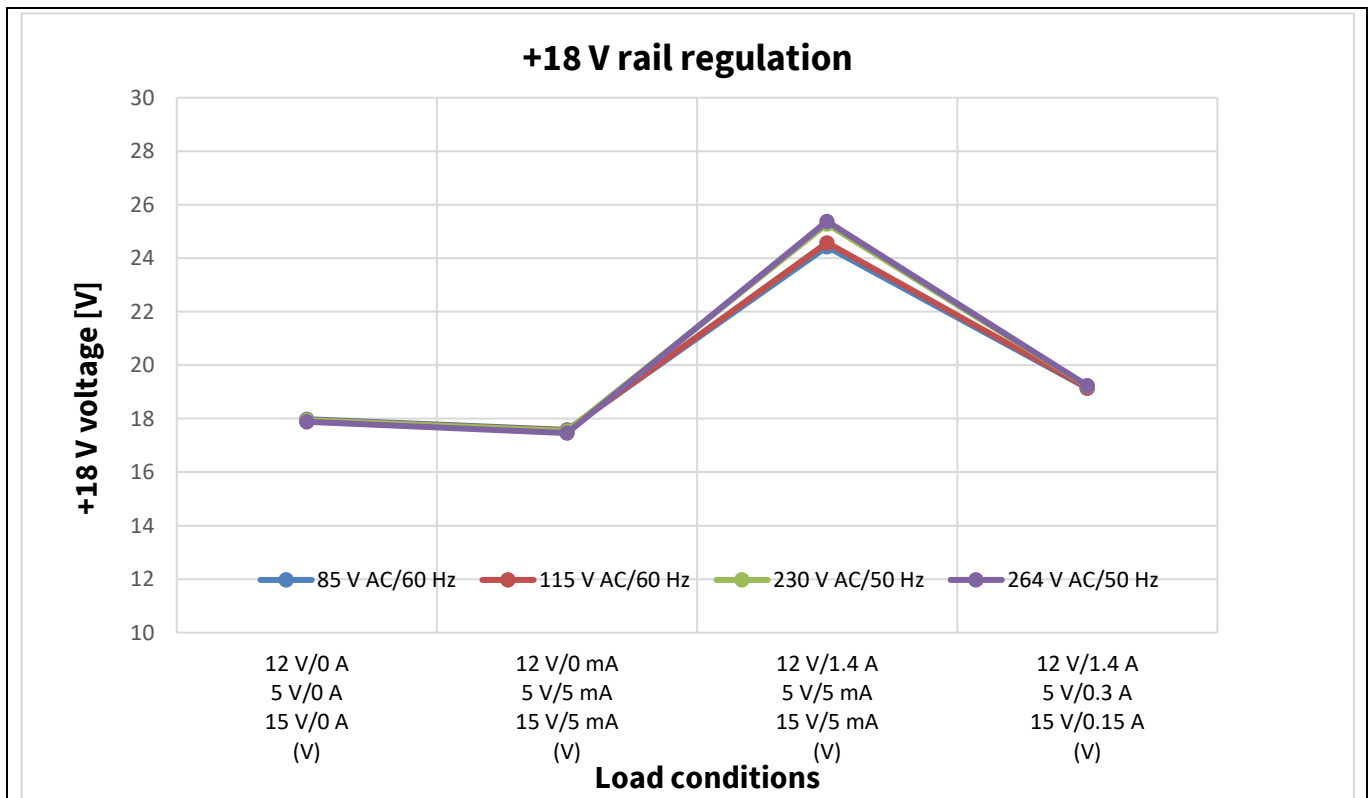

Figure 18 +18 V rail line and load regulation

Waveforms and oscilloscope plots

10 Waveforms and oscilloscope plots

All waveforms and scope plots were recorded with a Teledyne LeCroy Waverunner 8054 oscilloscope.

10.1 Start-up at full load

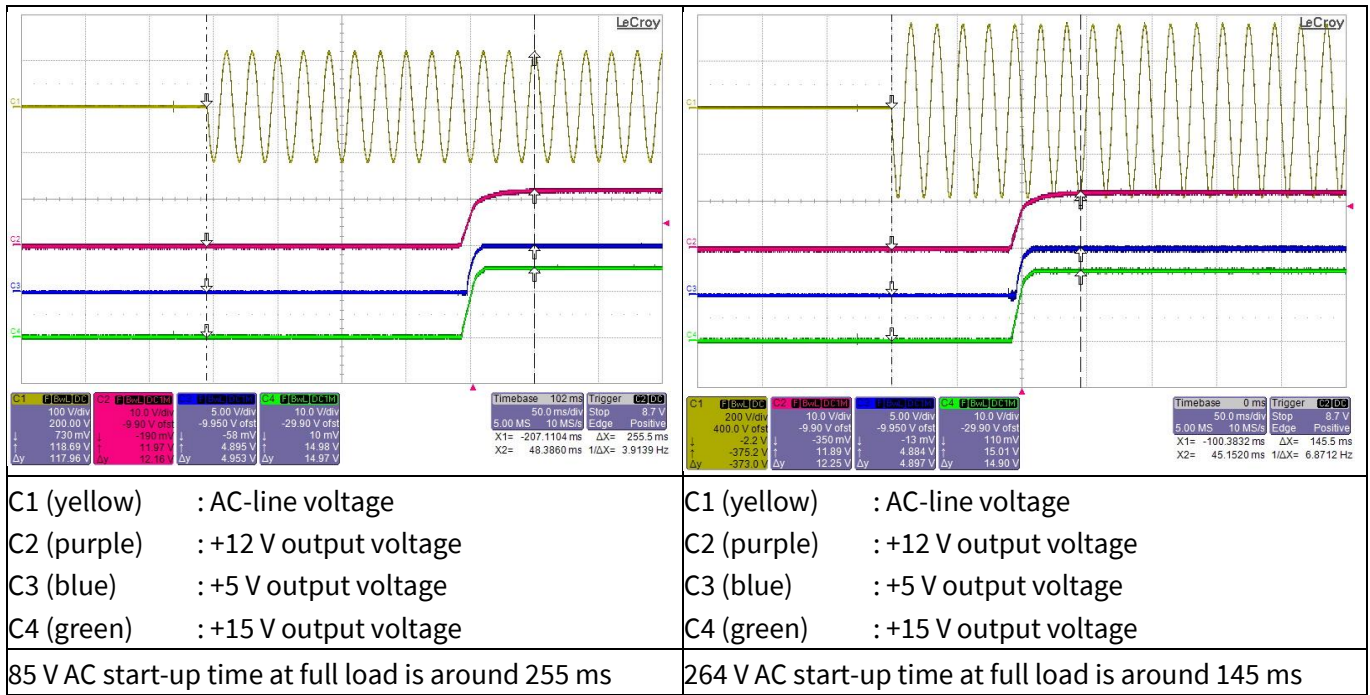

Figure 19 Start-up at full load

10.2 Soft-start at full load

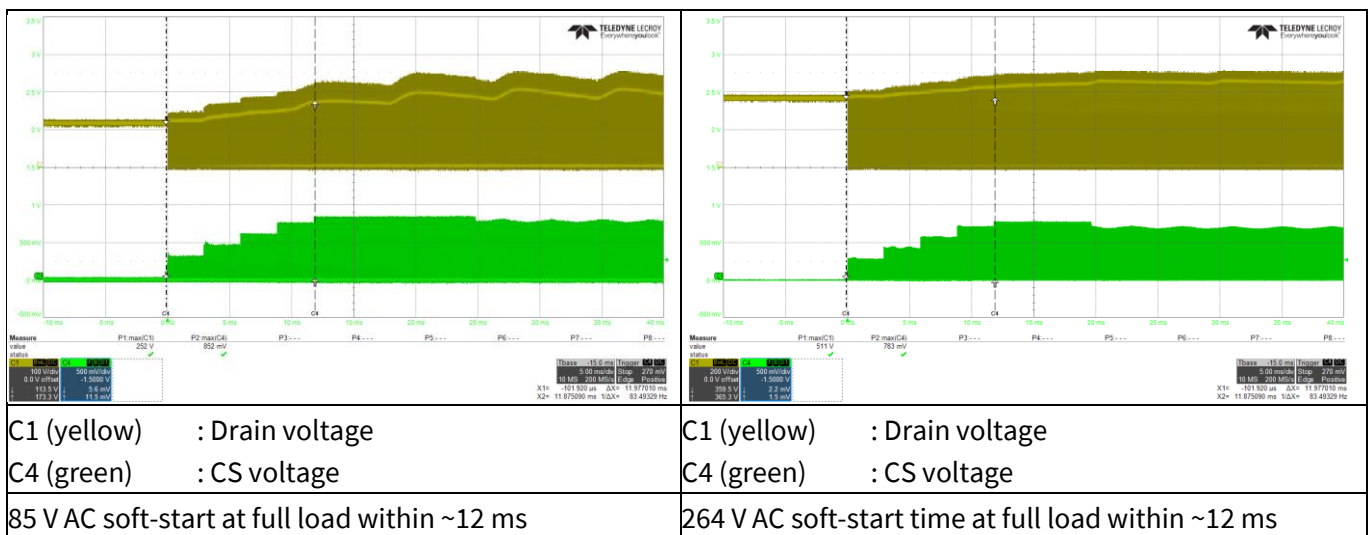

Figure 20 Soft-start at full load

Waveforms and oscilloscope plots

10.3 Drain and CS voltage at full load

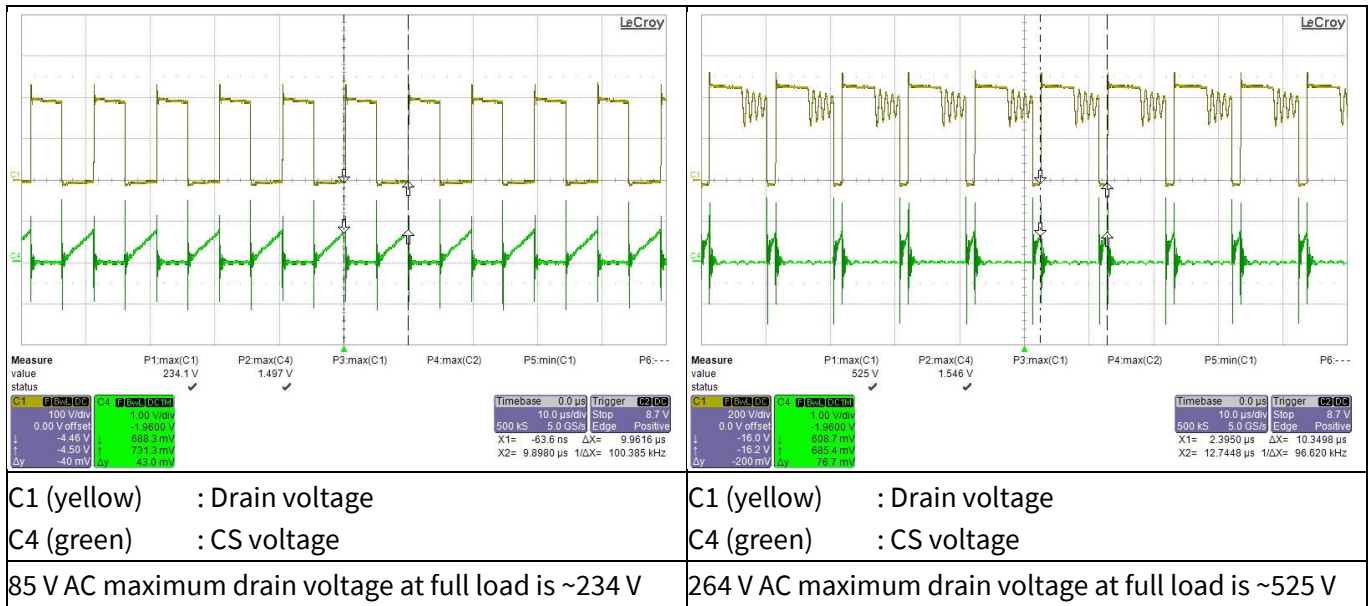

Figure 21 Drain and CS voltage at full load

10.4 Frequency jittering

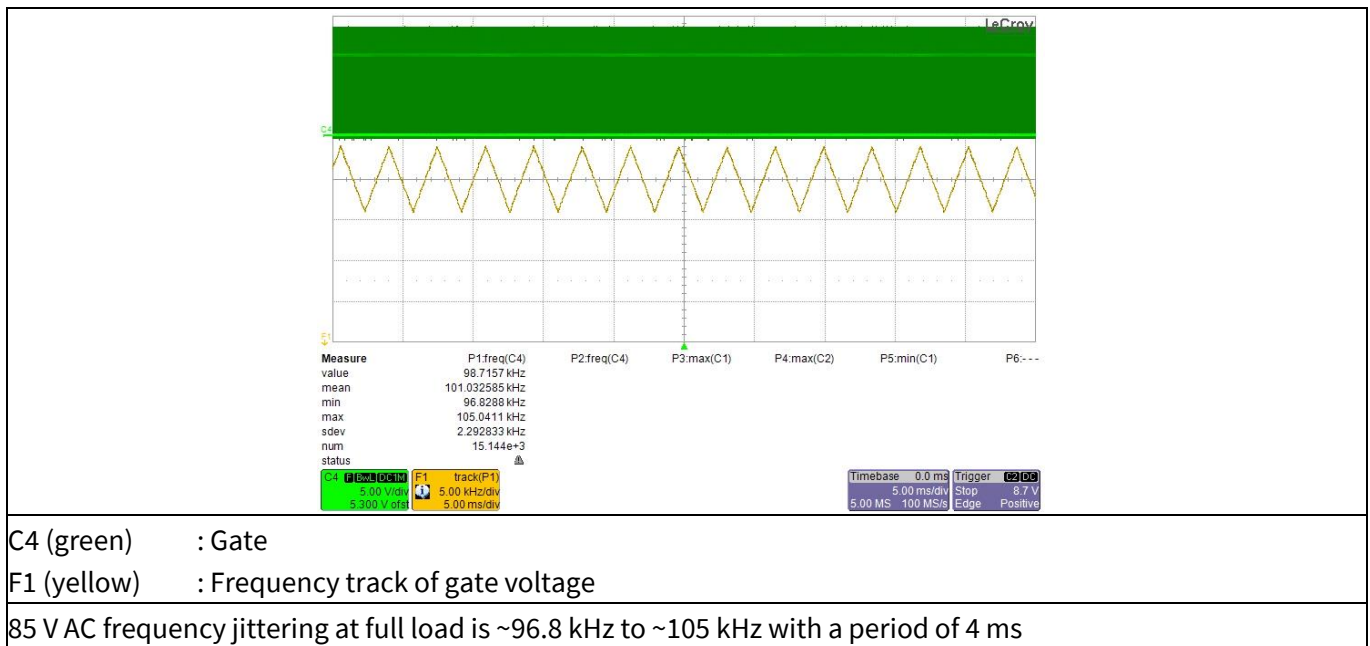

Figure 22 Frequency jittering at full load

Waveforms and oscilloscope plots

10.5 Load-transient response

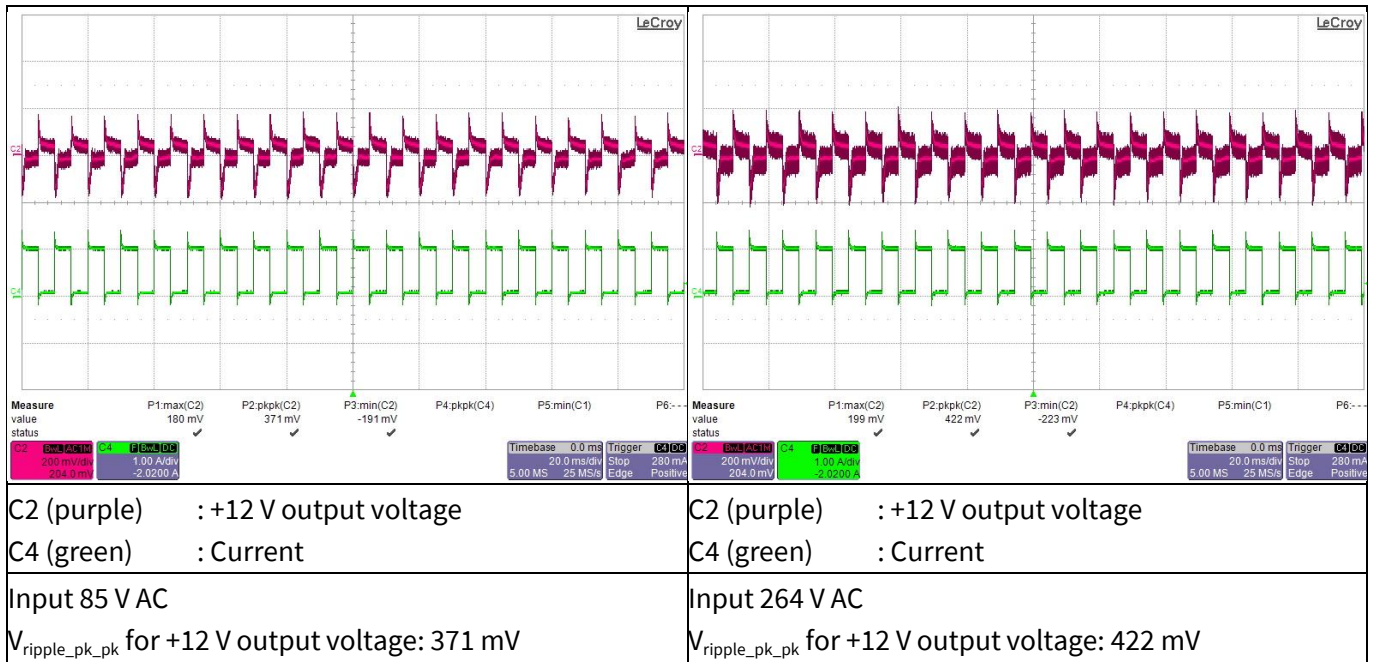

Figure 23 Load-transient response (+12 V output load change from 10 percent to 100 percent at 0.4 A/ μ s slew rate, 100 Hz, +15 V output and +5 V output load are fixed at full load; 20 MHz bandwidth and 10 μ F electrolytic capacitor in parallel with 0.1 μ F ceramic capacitor)

10.6 Output ripple voltage at full load

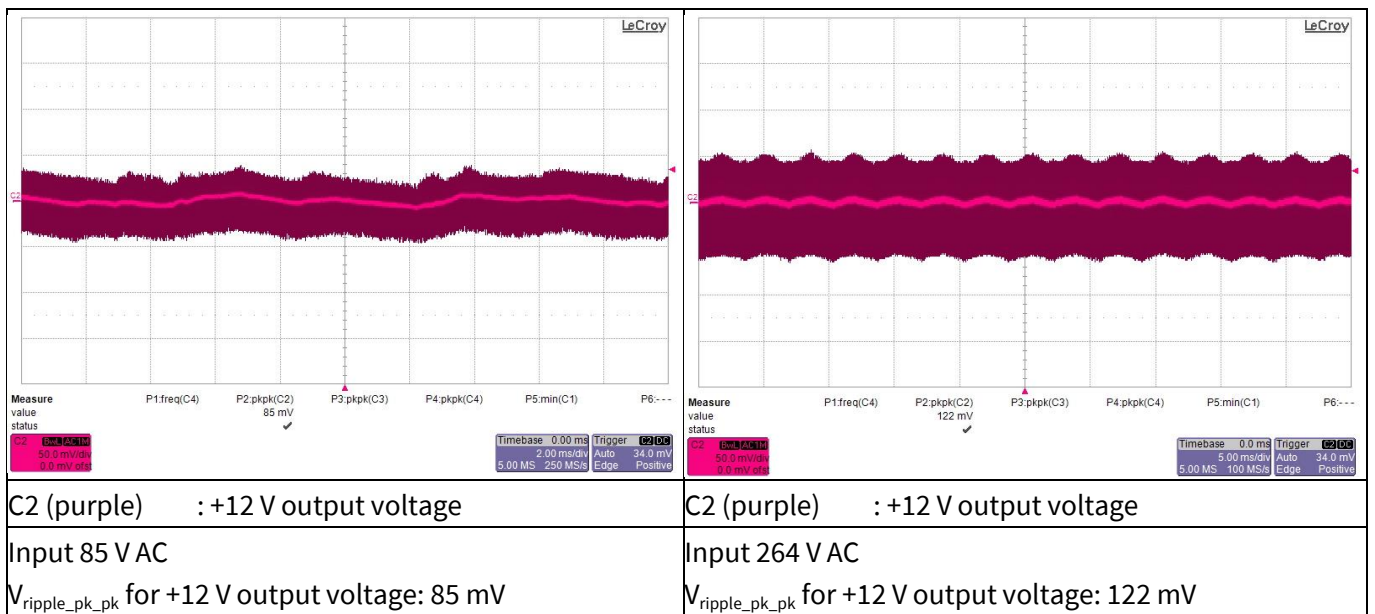

Figure 24 Output ripple voltage at full load (20 MHz bandwidth and 10 μ F electrolytic capacitor in parallel with 0.1 μ F ceramic capacitor)

Waveforms and oscilloscope plots

10.7 Output ripple voltage at ABM

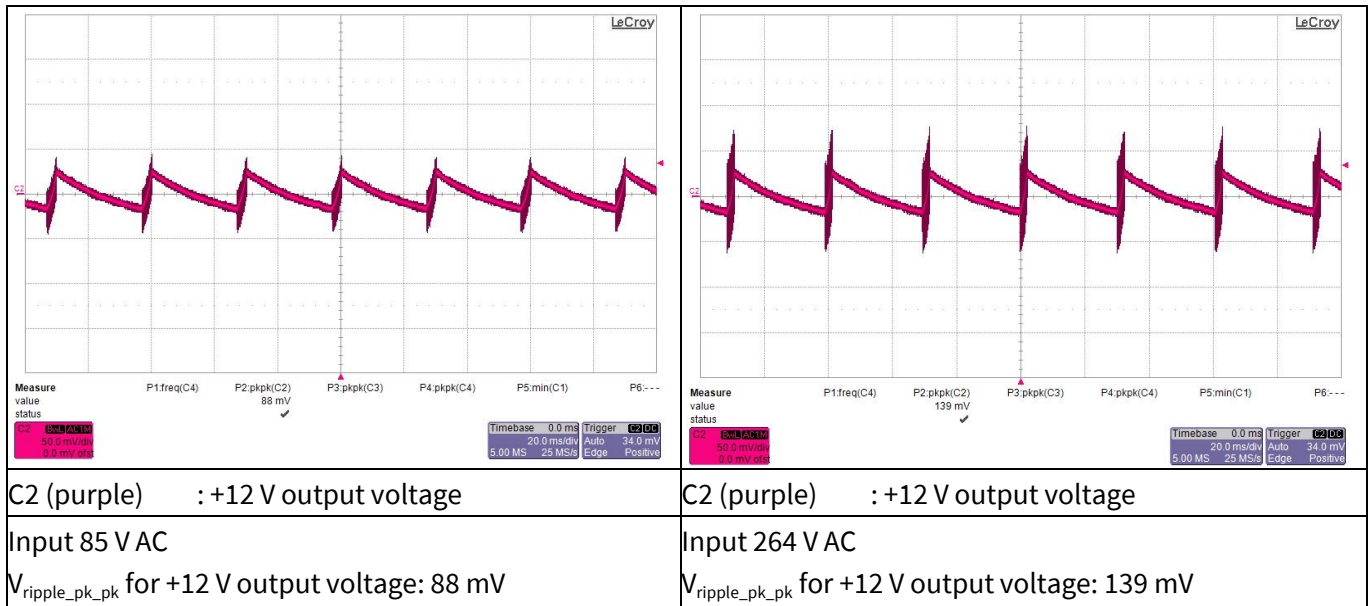

Figure 25 Output ripple voltage at ABM (20 MHz bandwidth and 10 µF electrolytic capacitor in parallel with 0.1 µF ceramic capacitor, minimum load)

10.8 Entering ABM

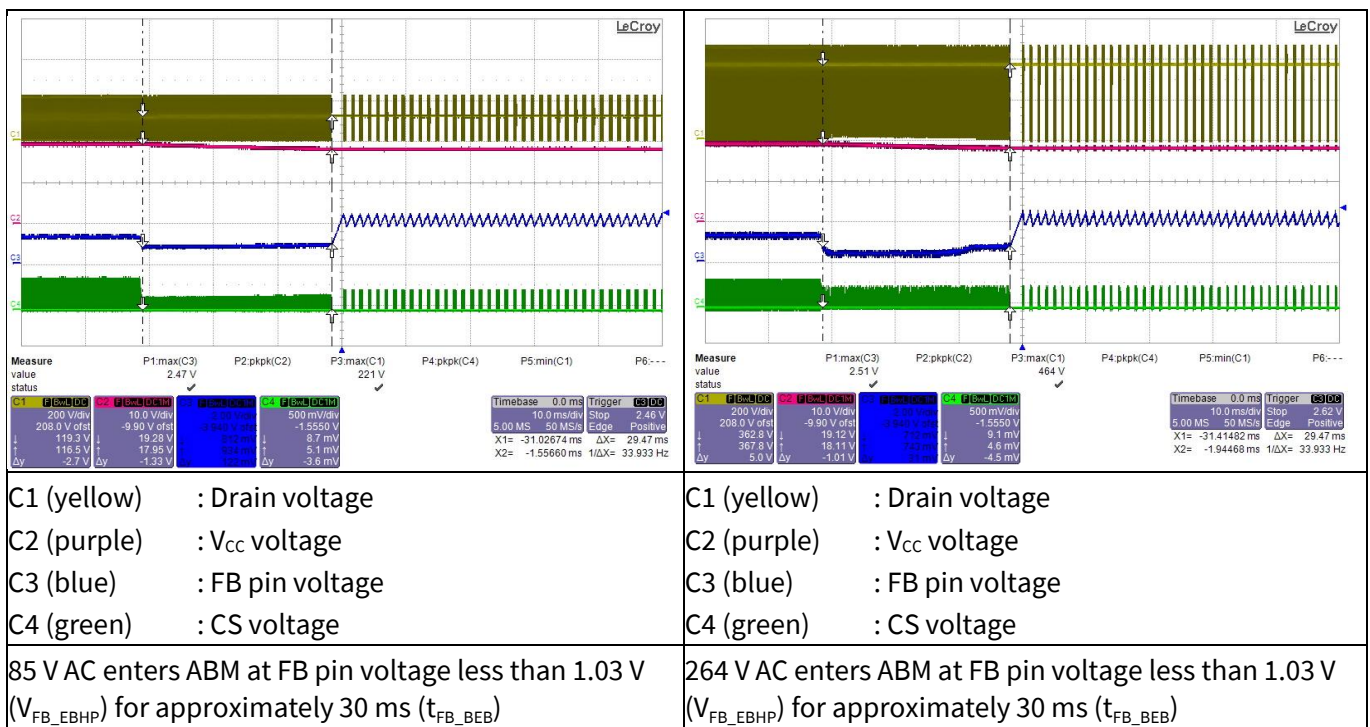

Figure 26 Entering ABM

22 W auxiliary power supply for indoor air-conditioner using ICE5AR2280CZ

Waveforms and oscilloscope plots

10.9 During ABM

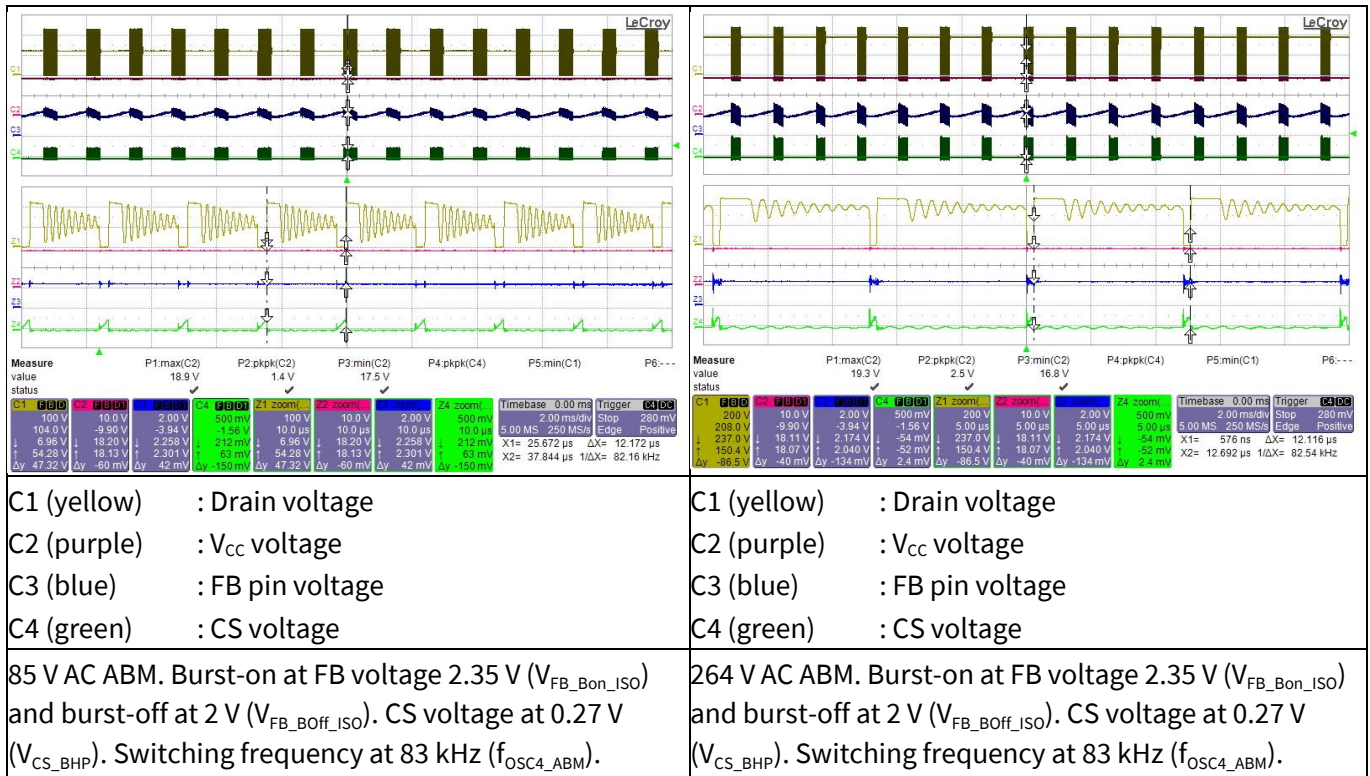

Figure 27 During ABM

10.10 Leaving ABM

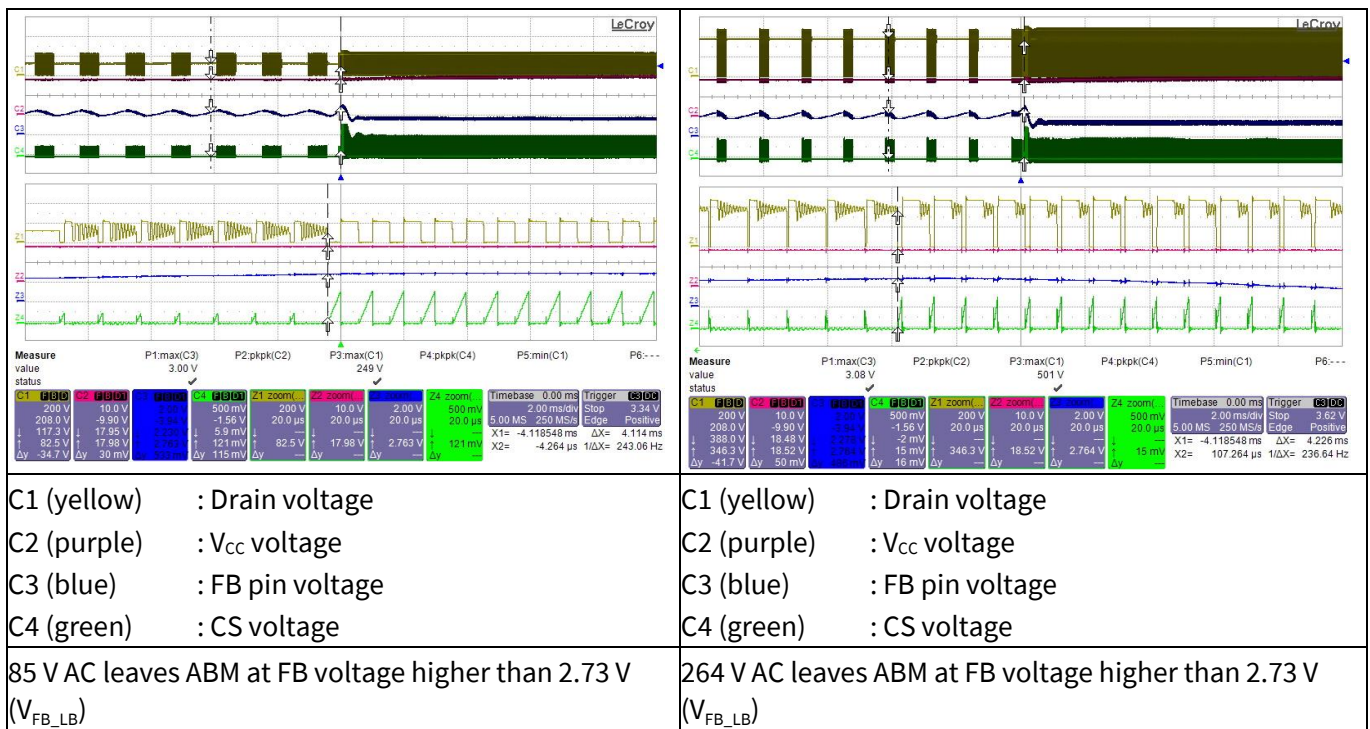

Figure 28 Leaving ABM

Waveforms and oscilloscope plots

10.11 V_{CC} OV/UV protection

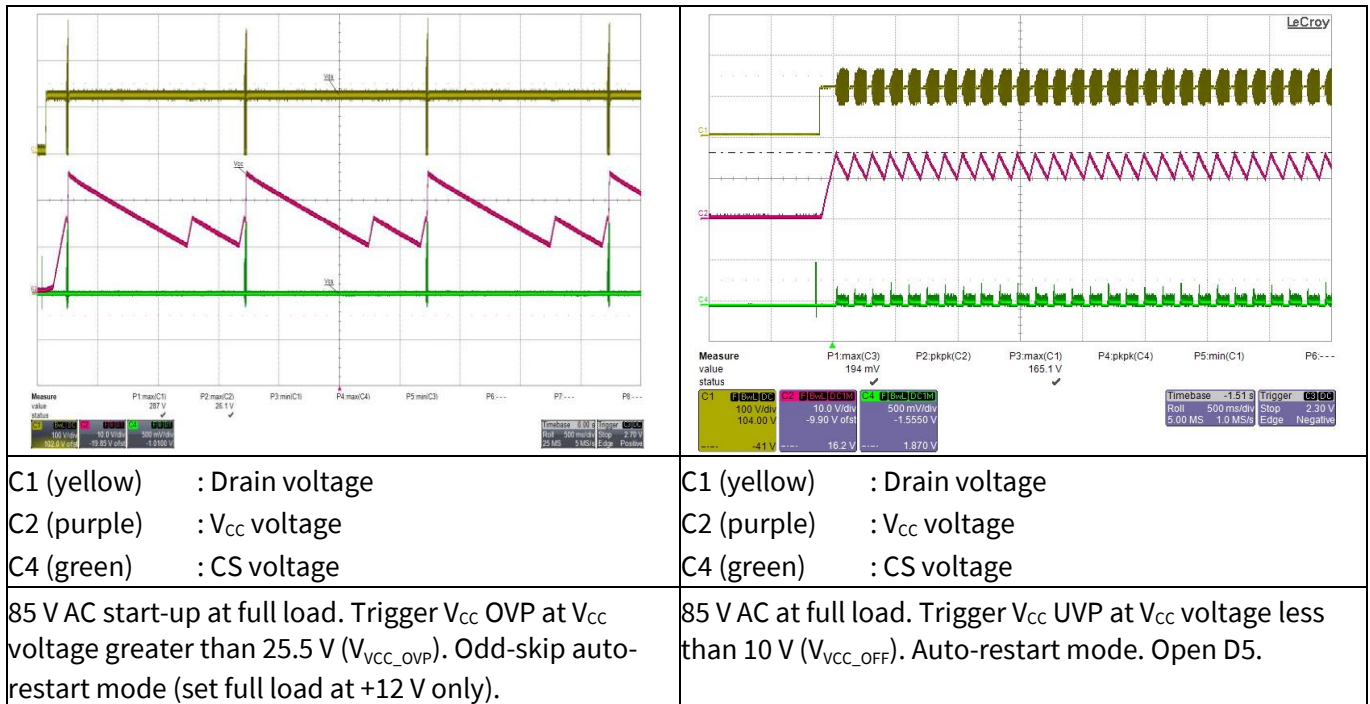

Figure 29 V_{CC} OV/UV protection

10.12 Overload protection

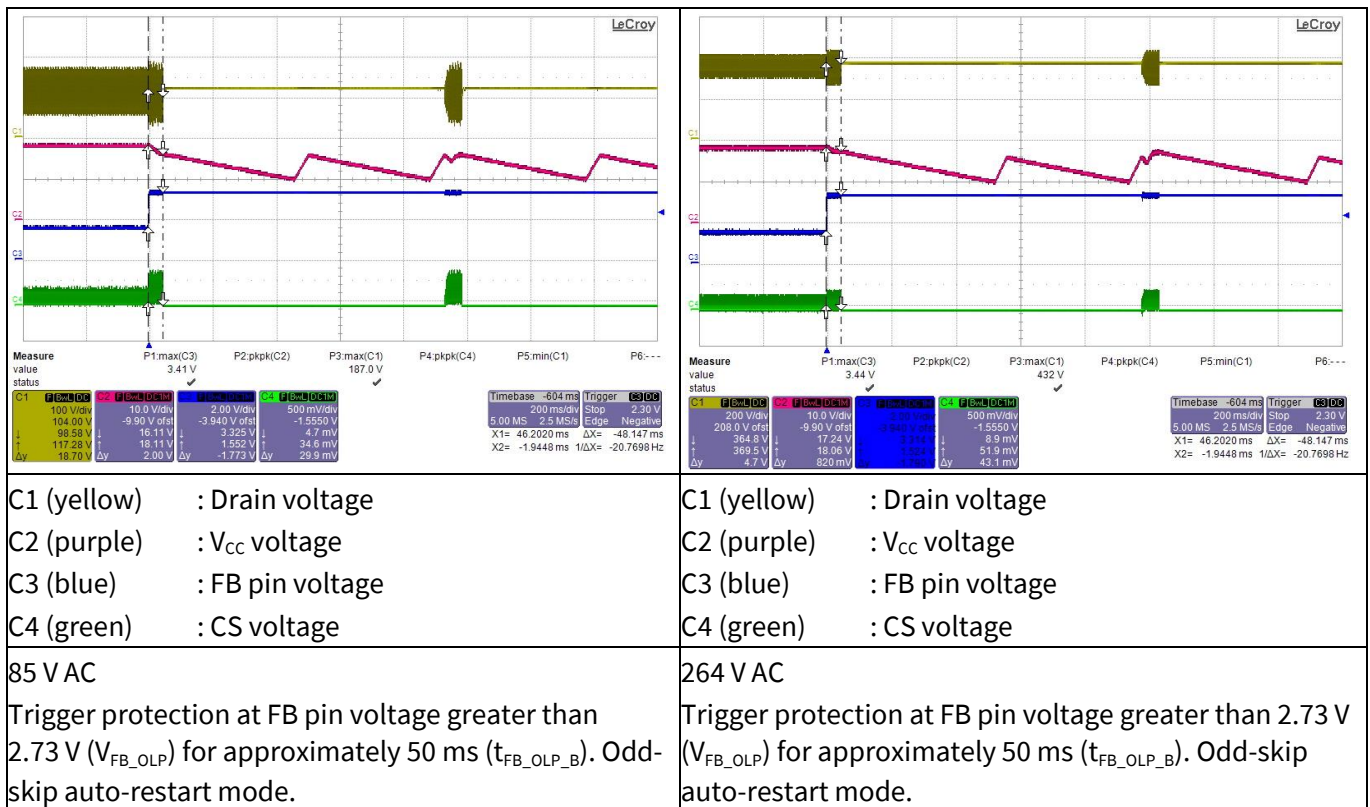
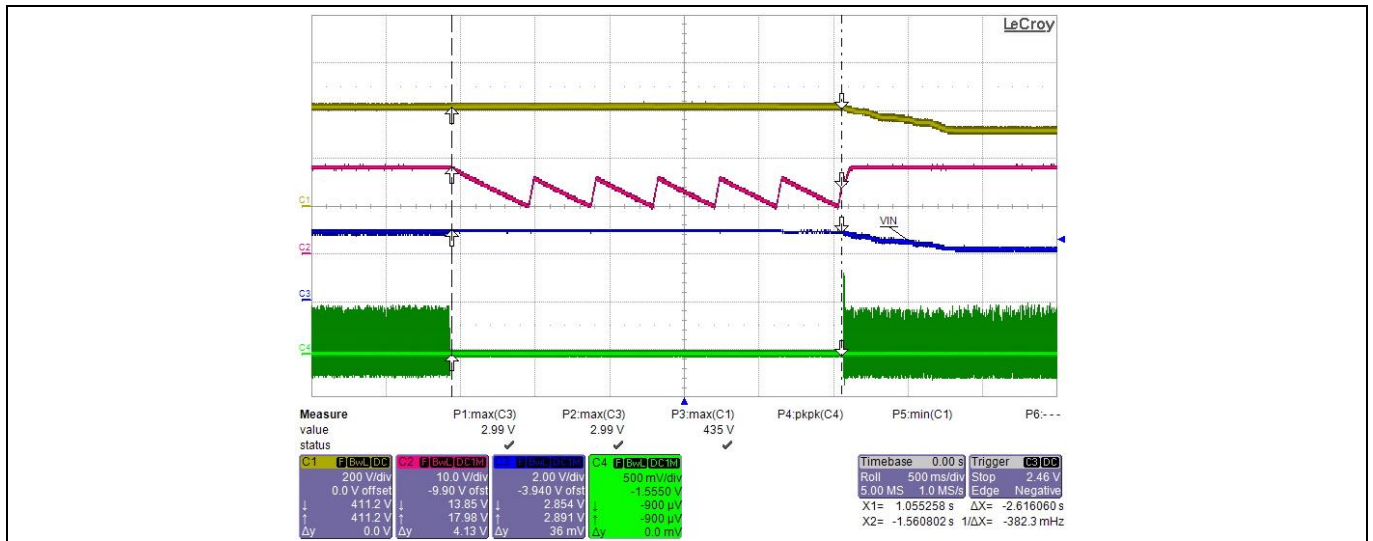

Figure 30 Overload protection

Waveforms and oscilloscope plots

10.13 Line overvoltage protection



- C1 (yellow) : Bus voltage
- C2 (purple) : V_{CC} voltage
- C3 (blue) : V_{IN} pin voltage
- C4 (green) : CS voltage

Trigger protection at V_{IN} pin voltage greater than 2.85 V (V_{VIN_LOVP}) for approximately 250 μs (t_{VIN_LOVP_B}). Non-switch auto-restart mode. Trigger at 295 V AC.

Figure 31 Line overvoltage protection

22 W auxiliary power supply for indoor air-conditioner using ICE5AR2280CZ



Appendix A: Transformer design and spreadsheet [3]

11 Appendix A: Transformer design and spreadsheet [3]

Calculation tool for FF flyback converter using fifth-generation CoolSET™ (Version 1.1)

Project:	REF_5AR2280CZ_22W1
Application:	Aux for residential air-conditioner unit
CoolSET™:	ICE5AR2280CZ
Date:	22 February 2022
Revision:	V 1.1

Notes:

Enter design variables in orange-colored cells

Read design results in green-colored cells

Equation numbers are according to the design guide

Component designators refer to the calculation tool

Select component values based on standard values available

Voltage/current rating does not include design margin, voltage spikes and transient currents

In “Output regulation”, only fill in either isolated or non-isolated, whichever is applicable

Description	Eq. #	Parameter	Unit	Value
Input, output, CoolSET™ specs				
Line input				
Input		Minimum AC input voltage	V_{ACMin}	[V] 85
Input		Maximum AC input voltage	V_{ACMax}	[V] 264
Input		Line frequency	f_{AC}	[Hz] 60
Input		Bus capacitor DC ripple voltage	$V_{DCRipple}$	[V] 25
Output 1 specs				
Input		Output voltage 1	V_{Out1}	[V] 12
Input		Output current 1	I_{Out1}	[A] 1.40
Input		Forward voltage of output diode 1	V_{FOut1}	[V] 0.6
Input		Output ripple voltage 1	$V_{OutRipple1}$	[V] 0.2
Result	Eq. 001	Output power 1	P_{Out1}	[W] 16.8
Result	Eq. 004	Output load weight 1	K_{L1}	0.77
Output 2 specs				
Input		Output voltage 2	V_{Out2}	[V] 8
Input		Output current 2	I_{Out2}	[A] 0.3
Input		Forward voltage of output diode 2	V_{FOut2}	[V] 0.2
Input		Output ripple voltage 2	$V_{OutRipple2}$	[V] 0.2
Result	Eq. 002	Output power 2	P_{Out2}	[W] 2.4
Result	Eq. 005	Output load weight 2	K_{L2}	0.11
Auxiliary				
Input		V_{CC} voltage	V_{Vcc}	[V] 18
Input		V_{CC} current (LDO output current)	I_{Out3}	[A] 0.15
Input		Forward voltage of V_{CC} diode (D2)	V_{FVcc}	[V] 0.6
Result	Eq. 002	Output power 3	P_{Out3}	[W] 2.7
Power				
Input		Efficiency	η	0.83
Result	Eq. 003	Nominal output power	P_{OutNom}	[W] 21.90
Input		Maximum output power for overload protection	P_{OutMax}	[W] 22
Result	Eq. 006	Maximum input power for overload protection	P_{InMax}	[W] 26.51
Input		Minimum output power	P_{OutMin}	[W] 1

22 W auxiliary power supply for indoor air-conditioner using ICE5AR2280CZ



Appendix A: Transformer design and spreadsheet [3]

Controller/CoolSET™

	Controller/ CoolSET™				ICE5AR2280CZ
Input	Switching frequency		f_s	[Hz]	100000
Input	Targeted max. drain source voltage		V_{DSMax}	[V]	650
Input	Max. ambient temperature		T_{amax}	[°C]	50

Diode bridge and input capacitor

Diode bridge

Input	Power factor		$\cos\phi$		0.6
Result	Maximum AC input current	Eq. 007	I_{ACRMS}	[A]	0.520
Result	Peak voltage at V_{ACMax}	Eq. 008	$V_{DCMaxPk}$	[V]	373.35

Input capacitor

Result	Peak voltage at V_{ACMin}	Eq. 009	$V_{DCMinPk}$	[V]	120.21
Result	Selected minimum DC input voltage	Eq. 010	$V_{DCMinSet}$	[V]	95.21
Result	Discharging time at each half-line cycle	Eq. 011	T_D	[ms]	6.59
Result	Required energy at discharging time of input capacitor	Eq. 012	W_{in}	[Ws]	0.17
Result	Calculated input capacitor	Eq. 013	C_{inCal}	[μ F]	64.88
Input	Select input capacitor (C1)		C_{in}	[μ F]	68
Result	Calculated minimum DC input voltage	Eq. 015	V_{DCMin}	[V]	96.50

Transformer design

Drain voltage and current waveform

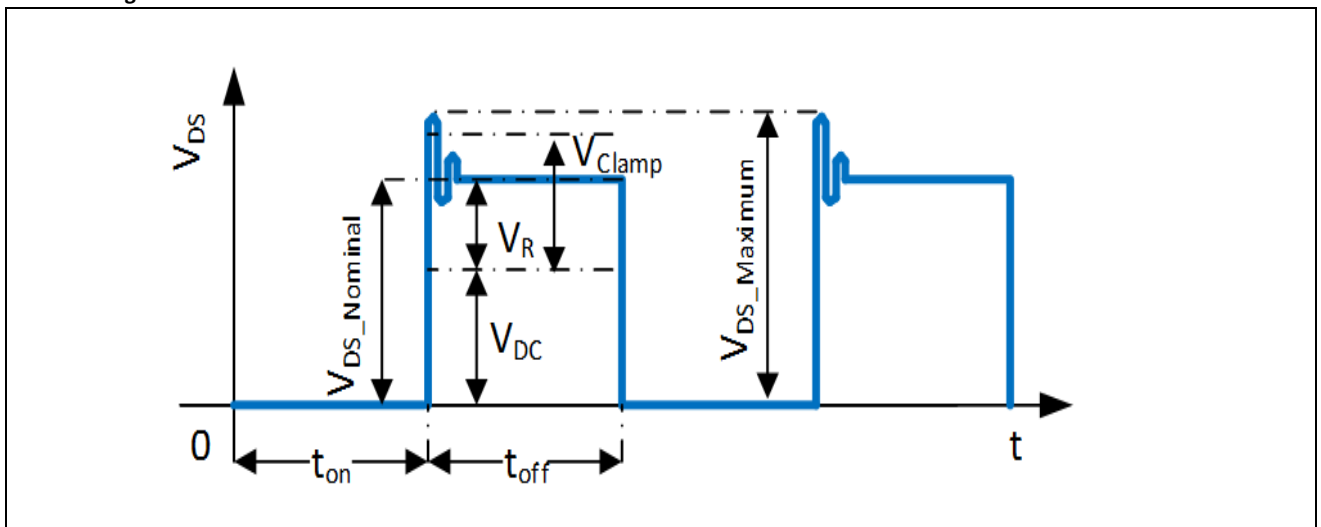

Appendix A: Transformer design and spreadsheet [3]

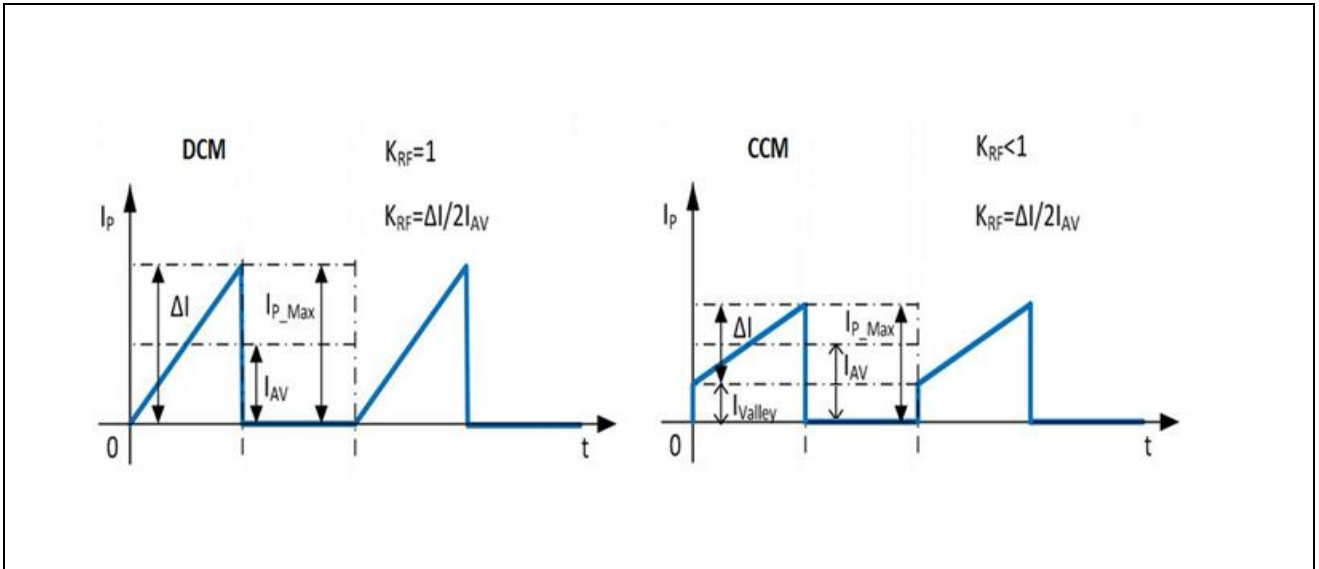

Primary inductance and winding currents

Input	Reflection voltage		V_{RSET}	[V]	92
Result	Maximum duty cycle	Eq. 016	D_{Max}		0.49
Input	Select current ripple factor		K_{RF}		1
Result	Primary inductance	Eq. 017	L_P	[H]	4.18E-04
Result	Primary turn-on average current	Eq. 018	I_{AV}	[A]	0.56
Result	Primary peak-to-peak current	Eq. 019	ΔI	[A]	1.13
Result	Primary peak current	Eq. 020	$I_{P_{Max}}$	[A]	1.13
Result	Primary valley current	Eq. 021	I_{Valley}	[A]	0.00
Result	Primary RMS current	Eq. 022	I_{PRMS}	[A]	0.454

Select core type

Input	Select core type				2
Result	Core type				E25/13/7
Result	Core material				TP4A(TDG)
Result	Maximum flux density		B_{Max}	[T]	0.3
Result	Cross-sectional area		A_e	[mm ²]	52
Result	Bobbin width		BW	[mm]	15.6
Result	Winding cross-section		A_N	[mm ²]	61
Result	Average length of turn		l_N	[mm]	50

Winding calculation

Result	Calculated minimum number of primary turns	Eq. 023	N_{PCal}	Turns	30.19
Input	Select number of primary turns		N_P	Turns	44
Result	Calculated number of secondary 1 turns	Eq. 024	N_{S1Cal}	Turns	6.03
Input	Select number of secondary 1 turns		N_{S1}	Turns	6
Result	Calculated number of secondary 2 turns	Eq. 025	N_{S2Cal}	Turns	3.92
Input	Select number of secondary 2 turns		N_{S2}	Turns	4
Result	Calculated number of auxiliary turns	Eq. 026	N_{VccCal}	Turns	8.86
Input	Select number of auxiliary turns		N_{Vcc}	Turns	8
Result	Calculated V_{CC} voltage	Eq. 027	V_{VccCal}	[V]	16.20

Post calculation

Result	Primary to secondary 1 turns ratio	Eq. 028	N_{PS1}		7.33
Result	Primary to secondary 2 turns ratio	Eq. 029	N_{PS2}		11.00
Result	Post calculated reflected voltage	Eq. 030	V_{RPost}	[V]	92.40
Result	Post calculated maximum duty cycle	Eq. 031	$D_{MaxPost}$		0.49

22 W auxiliary power supply for indoor air-conditioner using ICE5AR2280CZ



Appendix A: Transformer design and spreadsheet [3]

Result	Duty-cycle prime	Eq. 032	D_{Max}^1		0.51
Result	Actual flux density	Eq. 033	B_{MaxAct}	[T]	0.206
Result	Maximum DC input voltage for CCM operation	Eq. 034	$V_{DCmaxCCM}$	[V]	96.06

Transformer winding design

Input	Margin according to safety standard		M	[mm]	0
Input	Copper space factor		f_{Cu}		0.4
Result	Effective bobbin window	Eq. 035	BW_E	[mm]	15.6
Result	Effective winding cross-section	Eq. 036	A_{Ne}	[mm ²]	61.0
Input	Primary winding area factor		AF_{NP}		0.45
Input	Secondary 1 winding area factor		AF_{NS1}		0.30
Input	Secondary 2 winding area factor		AF_{NS2}		0.15
Input	Auxiliary winding area factor		AF_{NVcc}		0.1

Primary winding

Result	Calculated wire copper cross-sectional area	Eq. 037	A_{PCal}	[mm ²]	0.2495
Result	Calculated maximum wire size	Eq. 038	AWG_{PCal}		23
Input	Select wire size		AWG_P		26
Input	Select number of parallel wire		n_{WP}		1
Result	Wire copper diameter	Eq. 039	d_P	[mm]	0.41
Result	Wire copper cross-sectional area	Eq. 040	A_P	[mm ²]	0.1303
Result	Wire current density	Eq. 041	S_P	[A/mm ²]	3.48
Input	Insulation thickness		INS_P	[mm]	0.01
Result	Turns per layer	Eq. 042	NL_P	Turns/layer	36
Result	Number of layers	Eq. 043	Ln_P	Layers	2

Secondary 1 winding

Result	Calculated wire copper cross-sectional area	Eq. 044	A_{NS1Cal}	[mm ²]	1.2200
Result	Calculated maximum wire size	Eq. 045	AWG_{S1Cal}		16
Input	Select wire size		AWG_{S1}		23
Input	Select number of parallel wire		n_{WS1}		2
Result	Wire copper diameter	Eq. 046	d_{S1}	[mm]	0.5760
Result	Wire copper cross-sectional area	Eq. 047	A_{S1}	[mm ²]	0.5211
Result	Peak current	Eq. 048	I_{S1Max}	[A]	6.3321
Result	RMS current	Eq. 049	I_{S1RMS}	[A]	2.6100
Result	Wire current density	Eq. 050	S_{S1}	[A/mm ²]	5.01
Input	Insulation thickness		INS_{S1}	[mm]	0.02
Result	Turns per layer	Eq. 051	NL_{S1}	Turns/layer	6
Result	Number of layers	Eq. 052	Ln_{S1}	Layers	1

Secondary 2 winding

Result	Calculated wire copper cross-sectional area	Eq. 053	A_{NS2Cal}	[mm ²]	0.9150
Result	Calculated maximum wire size	Eq. 054	AWG_{S2Cal}		18
Input	Select wire size		AWG_{S2}		24
Input	Select number of parallel wire		n_{WS2}		1
Result	Wire copper diameter	Eq. 055	d_{S2}	[mm]	0.5131
Result	Wire copper cross-sectional area	Eq. 056	A_{S2}	[mm ²]	0.2068
Result	Peak current	Eq. 057	I_{S2Max}	[A]	1.3569
Result	RMS current	Eq. 058	I_{S2RMS}	[A]	0.5593
Result	Wire current density	Eq. 059	S_{S2}	[A/mm ²]	2.70

22 W auxiliary power supply for indoor air-conditioner using ICE5AR2280CZ



Appendix A: Transformer design and spreadsheet [3]

Input	Insulation thickness		INS _{S2}	[mm]	0.02
Result	Turns per layer	Eq. 060	NL _{S2}	Turns/layer	28
Result	Number of layers	Eq. 061	Ln _{S2}	Layers	1

RCD clamper and CS resistor

RCD clamper circuit

Input	Leakage inductance percentage		L _{LK%}	[%]	1
Result	Leakage inductance	Eq. 062	L _{LK}	[H]	4.18E-06
Result	Clamping voltage	Eq. 063	V _{Clamp}	[V]	184.25
Result	Calculated clamping capacitor	Eq. 064	C _{ClampCal}	[nF]	0.10
Input	Select clamping capacitor value (C2)		C _{Clamp}	[nF]	1
Result	Calculated clamping resistor	Eq. 065	R _{ClampCal}	[kΩ]	256.5
Input	Select clamping resistor value (R4)		R _{Clamp}	[kΩ]	240

Current sense resistor

Input	CS threshold value from datasheet		V _{CS_N}	[V]	0.8
Result	Calculated CS resistor (R8A, R8B)	Eq. 066	R _{sense}	[Ω]	0.71

Output rectifier

Secondary 1 output rectifier

Result	Diode reverse voltage	Eq. 067	V _{RDiode1}	[V]	62.91
Result	Diode RMS current		I _{S1RMS}	[A]	2.61
Input	Max. voltage undershoot at output capacitor		ΔV _{Out1}	[V]	0.5
Input	Number of clock periods		n _{cp1}		20
Result	Output capacitor ripple current	Eq. 068	I _{Ripple1}	[A]	2.20
Result	Calculated minimum output capacitor	Eq. 069	C _{Out1Cal}	[μF]	560
Input	Select output capacitor value (C152)		C _{Out1}	[μF]	560
Input	ESR (Z _{max}) value from datasheet at 100 kHz		R _{ESR1}	[Ω]	0.032
Input	Number of parallel capacitors		n _{CCOut1}		1
Result	Zero frequency of output capacitor	Eq. 070	f _{ZCOut1}	[kHz]	8.88
Result	First stage ripple voltage	Eq. 071	V _{Ripple1}	[V]	0.202627
Input	Select LC filter inductor value (L151)		L _{out1}	[μH]	4.7
Result	Calculated LC filter capacitor	Eq. 072	C _{LCCal1}	[μF]	68.3
Input	Select LC filter capacitor value (C153)		C _{LC1}	[μF]	220
Result	LC filter frequency	Eq. 073	f _{LC1}	[kHz]	4.95
Result	Second stage ripple voltage	Eq. 074	V _{2ndRipple1}	[mV]	0.50

Secondary 2 output rectifier

Result	Diode reverse voltage	Eq. 075	V _{RDiode2}	[V]	41.94
Result	Diode RMS current		I _{S2RMS}	[A]	0.56

V_{CC} diode and capacitor

V_{CC} diode and capacitor

Result	Auxiliary diode reverse voltage (D2)	Eq. 083	V _{RDiodeVCC}	[V]	84.08
Input	Soft-start time from datasheet		t _{ss}	[ms]	12
Input	I _{VCC_Charge3} from datasheet		I _{VCC_Charge3}	[mA]	3
Input	V _{CC} on-threshold		V _{VCC_ON}	[V]	16
Input	V _{CC} off-threshold		V _{VCC_OFF}	[V]	10
Result	Calculated V _{CC} capacitor	Eq. 084	C _{VCCCal}	[μF]	6.00
Input	Select V _{CC} capacitor (C3)		C _{VCC}	[μF]	22
Input	V _{CC} short threshold from datasheet		V _{VCC_SCP}	[V]	1.1
Input	I _{VCC_Charge1} from datasheet		I _{VCC_Charge1}	[mA]	0.2
Result	Start-up time	Eq. 085	t _{StartUp}	[ms]	230.267

22 W auxiliary power supply for indoor air-conditioner using ICE5AR2280CZ



Appendix A: Transformer design and spreadsheet [3]

Calculation of losses

Input diode bridge

Input	Diode bridge forward voltage		V_{FBR}	[V]	1
Result	Diode bridge power loss	Eq. 086	P_{DIN}	[W]	1.14

Transformer copper

Result	Primary winding copper resistance	Eq. 087	R_{PCu}	[mΩ]	290.39
Result	Secondary 1 winding copper resistance	Eq. 088	R_{S1Cu}	[mΩ]	9.90
Result	Secondary 2 winding copper resistance	Eq. 089	R_{S2Cu}	[mΩ]	16.63
Result	Primary winding copper loss	Eq. 090	P_{PCu}	[mW]	59.86
Result	Secondary 1 winding copper loss	Eq. 091	P_{S1Cu}	[mW]	67.46
Result	Secondary 2 winding copper loss	Eq. 092	P_{S2Cu}	[mW]	5.20
Result	Total transformer copper loss	Eq. 093	P_{Cu}	[W]	0.1325

Output rectifier diode

Result	Secondary 1 diode loss	Eq. 094	P_{Diode1}	[W]	1.57
Result	Secondary 2 diode loss	Eq. 095	P_{Diode2}	[W]	0.11

RCD clamper circuit

Result	RCD clamper loss	Eq. 096	$P_{Clamper}$	[W]	0.4
--------	------------------	---------	---------------	-----	-----

Current sense resistor

Result	Current sense resistor loss	Eq. 097	P_{CS}	[W]	0.15
--------	-----------------------------	---------	----------	-----	------

MOSFET

Input	$R_{DS(on)}$ from datasheet		$R_{DS(on)}$ at $T_A = 125^\circ\text{C}$	[Ω]	4.31
Input	$C_{o(er)}$ from datasheet		$C_{o(er)}$	[pF]	7
Input	External drain-to-source capacitance		C_{DS}	[pF]	0
Result	Switch-on loss at minimum AC input voltage	Eq. 098	$P_{SONMinAC}$	[W]	0.0125
Result	Conduction loss at minimum AC input voltage	Eq. 099	$P_{condMinAC}$	[W]	0.8884
Result	Total MOSFET loss at minimum AC input voltage	Eq. 100	$P_{MOSMinAC}$	[W]	0.9009
Result	Switch-on loss at maximum AC input voltage	Eq. 101	$P_{SONMaxAC}$	[W]	0.0759
Result	Conduction loss at maximum AC input voltage	Eq. 102	$P_{condMaxAC}$	[W]	0.2293
Result	Total MOSFET loss at maximum AC input voltage	Eq. 103	$P_{MOSMaxAC}$	[W]	0.3052
Result	Total MOSFET loss (from minimum or maximum AC)		P_{MOS}	[W]	0.9009

Controller

Input	Controller current consumption		I_{VCC_Normal}	[mA]	2.3
Result	Controller loss	Eq. 104	P_{Ctrl}	[W]	0.0373

Efficiency after losses

Result	Total power loss	Eq. 105	P_{Losses}	[W]	4.44
Result	Post calculated efficiency	Eq. 106	η_{Post}	%	83.22%

CoolSET™/MOSFET temperature

CoolSET™/MOSFET temperature

Input	Enter thermal resistance junction-ambient (include copper pour)		$R_{thJA,As}$	[°K/W]	80.0
Result	Temperature rise	Eq. 107	ΔT	[°K]	72.1
Result	Junction temperature at T_{amax}	Eq. 108	T_{jmax}	[°C]	122.1

Line OVP

Line OVP

Input	Select AC input LOVP		V_{OVP_AC}	[V AC]	300
Input	High-side DC input voltage divider resistor (R3A, R3B, R3C)		R_{I1}	[mΩ]	10
Input	Controller LOVP threshold		V_{VIN_LOVP}	[V]	2.85

22 W auxiliary power supply for indoor air-conditioner using ICE5AR2280CZ

Appendix A: Transformer design and spreadsheet [3]

Result	Low-side DC input voltage divider resistor	Eq. 109	R_{I2Cal}	[k Ω]	68.824
Input	Select low-side DC input voltage divider resistor (R7)		R_{I2}	[k Ω]	68.1
Result	Post calculated LOVP	Eq. 110	V_{OVP_ACPost}	[V AC]	303

Output regulation (isolated using TL431 and optocoupler)

Isolated feedback circuit

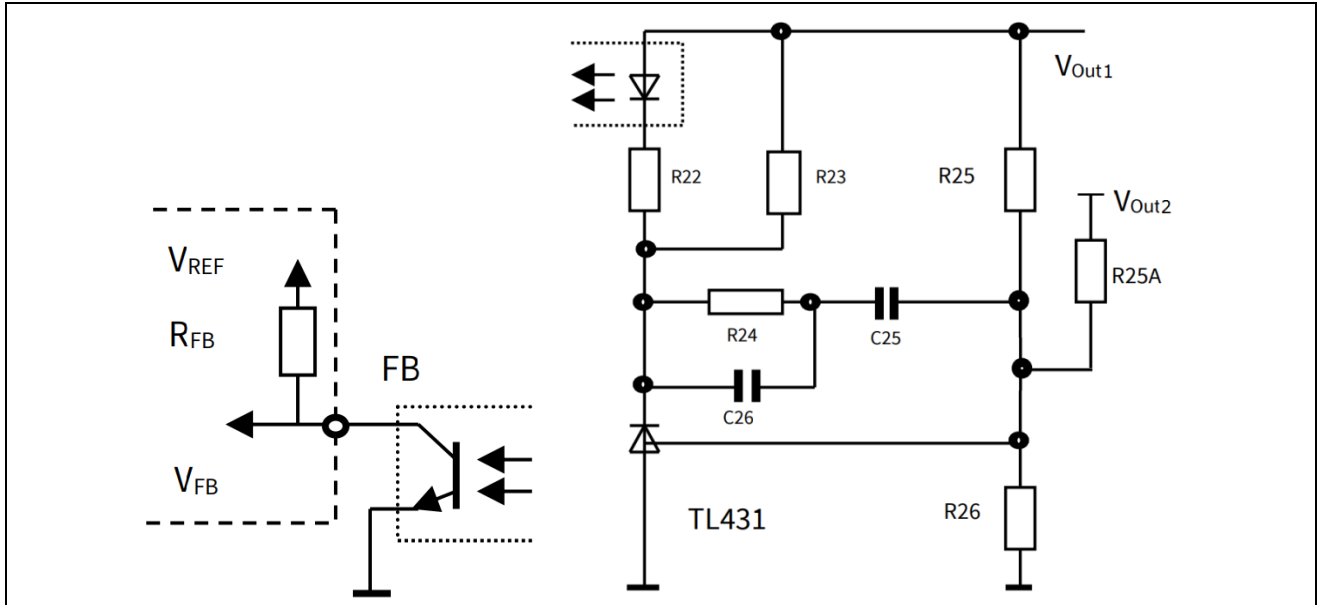

Output regulation

Input	TL431 reference voltage		V_{REF_TL}	[V]	2.5
Input	Weighted regulation factor of V_{Out1}		W_1		1
Input	Current for voltage divider resistor R26		I_{R26}	[mA]	0.25
Result	Calculated voltage divider resistor	Eq. 111	R_{26Cal}	[k Ω]	10
Input	Select voltage divider resistor value		R26	[k Ω]	10
Result	Calculated voltage divider resistor	Eq. 112	R_{25Cal}	[k Ω]	38.00
Input	Select voltage divider resistor value		R25	[k Ω]	38.0

Optocoupler and TL431 bias

Input	Current transfer ratio (CTR)		G_C	[%]	200%
Input	Optocoupler diode forward voltage		V_{FOpto}	[V]	1.25
Input	Maximum current for optocoupler diode		I_{Fmax}	[mA]	50
Input	Minimum current for TL431		I_{KAmin}	[mA]	1
Result	Calculated minimum optocoupler bias resistance	Eq. 114	R_{22Cal}	[k Ω]	0.1650
Input	Select optocoupler bias resistor		R22	[k Ω]	1
Input	FB pull-up reference voltage V_{REF} from datasheet		V_{REF}	[V]	3.3
Input	V_{FB_OLP} from datasheet		V_{FB_OLP}	[V]	2.75
Input	R_{FB} from datasheet		R_{FB}	[k Ω]	15
Result	Calculated maximum TL431 bias resistance	Eq. 115	R_{23Cal}	[k Ω]	1.27
Input	Selected TL431 bias resistor		R23	[k Ω]	1

Regulation loop

Result	Feedback transfer characteristic	Eq. 116	K_{FB}		30.00
Result	Gain of feedback transfer characteristic	Eq. 117	G_{FB}	[dB]	29.54
Result	Voltage divider transfer characteristic	Eq. 118	K_{VD}		0.208333
Result	Gain of voltage divider transfer characteristic	Eq. 119	G_{VD}	[dB]	-13.62
Result	Resistance at maximum load pole	Eq. 120	R_{LH}	[Ω]	6.55
Result	Resistance at minimum load pole	Eq. 121	R_{LL}	[Ω]	144.00
Result	Poles of power stage at maximum load pole	Eq. 122	f_{OH}	[Hz]	86.84

22 W auxiliary power supply for indoor air-conditioner using ICE5AR2280CZ



Appendix A: Transformer design and spreadsheet [3]

Result	Poles of power stage at minimum load pole	Eq. 123	f_{OL}	[Hz]	3.95
Result	Zero frequency of the compensation network	Eq. 124	f_{OM}	[Hz]	18.51
Input	Zero dB crossover frequency		f_g	[kHz]	8
Input	PWM-OP gain from datasheet		A_V		2.03
Result	Transient impedance	Eq. 117	Z_{PWM}	[V/A]	1.8
Result	Power stage at crossover frequency	Eq. 118	$ F_{PWR}(f_g) $		0.064
Result	Gain of power stage at crossover frequency	Eq. 119	$G_{PWR}(f_g)$	[dB]	-23.85
Result	Gain of the regulation loop at f_g	Eq. 120	$G_S(\omega)$	[dB]	-7.937
Result	Separated components of the regulator	Eq. 121	$G_r(\omega)$	[dB]	7.937
Result	Calculated resistance value of compensation network	Eq. 122	$R_{24_{cal}}$	[k Ω]	19.74
Input	Select resistor value of compensation network		R_{24}	[k Ω]	22
Result	Calculated capacitance value of compensation network	Eq. 123	$C_{26_{cal}}$	[nF]	0.904
Input	Select capacitor value of compensation network		C_{26}	[nF]	0.68
Result	Calculated capacitance value of compensation network	Eq. 124	$C_{25_{cal}}$	[nF]	390.06
Input	Select capacitor value of compensation network		C_{25}	[nF]	220

Final design

Electrical

Minimum AC voltage		[V]	85
Maximum AC voltage		[V]	264
Maximum input current		[A]	0.31
Minimum DC voltage		[V]	96
Maximum DC voltage		[V]	373
Maximum output power		[W]	22.0
Output voltage 1		[V]	12.0
Output ripple voltage 1		[mV]	0.5
Output voltage 2		[V]	8.0
Transformer peak current		[A]	1.13
Maximum duty cycle			0.49
Reflected voltage		[V]	92
Copper losses		[W]	0.13
MOSFET losses		[W]	0.90
Sum losses		[W]	4.44
Efficiency		[%]	83.22%

Transformer

Core type			E25/13/7
Core material			TP4A(TDG)
Effective core area		[mm ²]	52
Maximum flux density		[mT]	206
Inductance		[μ H]	418
Margin		[mm]	0
Primary turns		Turns	44
Primary copper wire size		AWG	26
Number of primary copper wire in parallel			1
Primary layers		Layer	2
Secondary 1 turns (N_{S1})		Turns	6
Secondary 1 copper wire size		AWG	23
Number of secondary 1 copper wire in parallel			2
Secondary 1 layers		Layer	1
Secondary 2 turns (N_{S2})		Turns	4
Secondary 2 copper wire size		AWG	24
Number of secondary 2 copper wire in parallel			1
Secondary 2 layers		Layer	1
Auxiliary turns		Turns	8
Leakage inductance		[μ H]	4.2

Components

Input capacitor (C1)		[μ F]	68.0
Secondary 1 output capacitor (C152)		[μ F]	560.0

22 W auxiliary power supply for indoor air-conditioner using ICE5AR2280CZ



Appendix A: Transformer design and spreadsheet [3]

Secondary 1 output capacitor in parallel				1.0
Secondary 1 LC filter inductor (L151)			[μ H]	4.7
Secondary 1 LC filter capacitor (C153)			[μ F]	220.0
V _{CC} capacitor (C3)			[μ F]	22.0
Sense resistor (R8A, R8B)			[Ω]	0.71
Clamping resistor (R4)			[k Ω]	240.0
Clamping capacitor (C2)			[nF]	1
High-side DC input voltage divider resistor (R3A, R3B, R3C)			[m Ω]	10
Low-side DC input voltage divider resistor (R7)			[k Ω]	68.1

Regulation components (isolated using TL431 and optocoupler)

Voltage divider		R26	[k Ω]	10.0
Voltage divider (V _{O1} sense)		R25	[k Ω]	38.0
Voltage divider (V _{O2} sense)		R25A	[k Ω]	0.0
Optocoupler bias resistor		R22	[k Ω]	1.00
TL431 bias resistor		R23	[k Ω]	1.0
Compensation network resistor		R24	[k Ω]	22.0
Compensation network capacitor		C26	[nF]	0.68
Compensation network capacitor		C25	[nF]	220.0

22 W auxiliary power supply for indoor air-conditioner using ICE5AR2280CZ



Appendix B: WE transformer specification

12 Appendix B: WE transformer specification

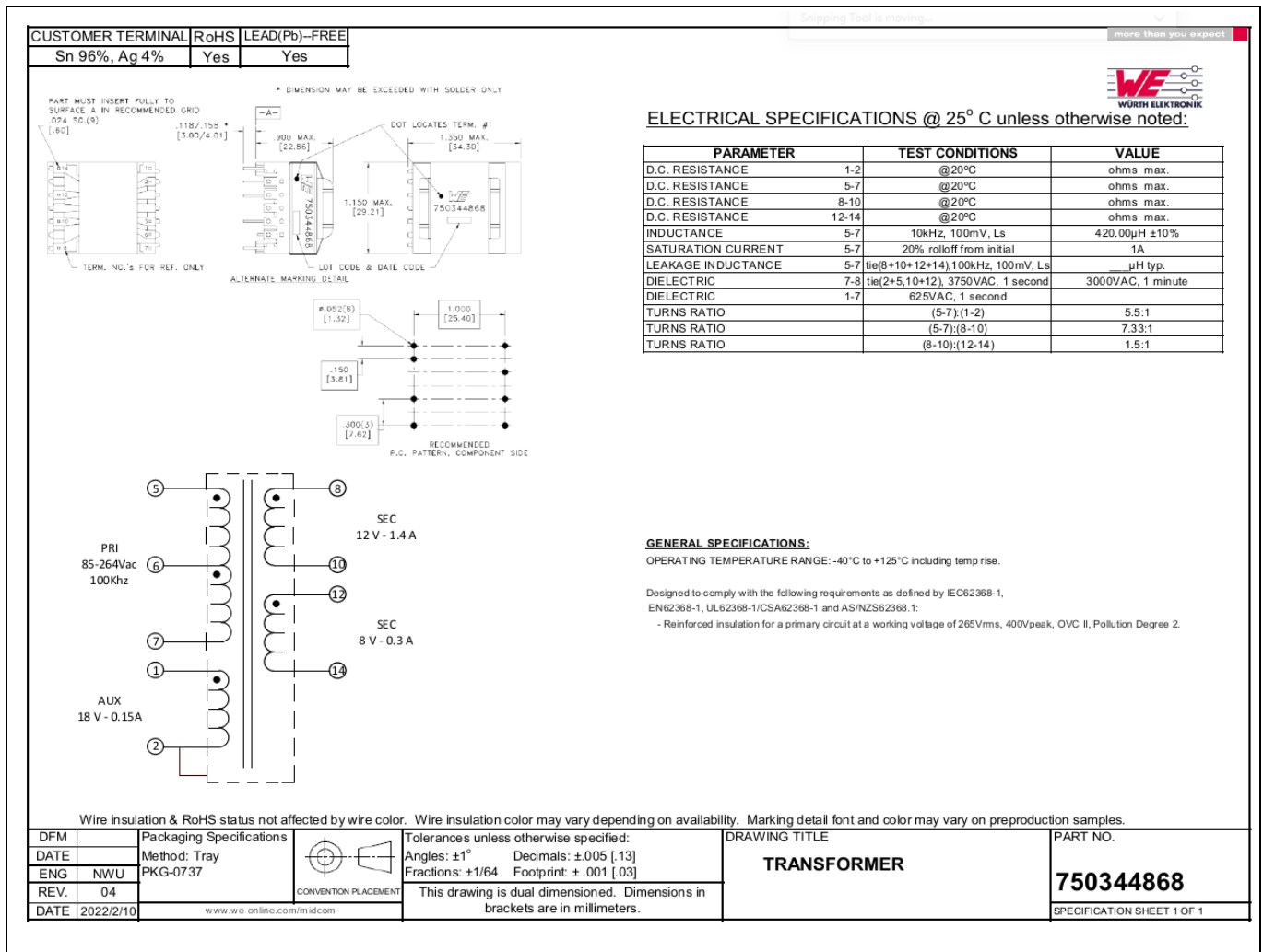

Figure 32 WE transformer specification

References

13 References

- [1] Infineon Technologies AG: Fixed-frequency 800 V / 950 V CoolSET™, ICE5xRxxxxxZ Datasheet (V 1.0); 2022-02-22; [ICE5xRxxxxxZ Datasheet](#)
- [2] Infineon Technologies AG: Fifth-generation fixed-frequency design guide (V 1.1); 2019-07-24; [Fifth-generation fixed-frequency design guide](#)
- [3] Infineon Technologies AG: Calculation tool for fixed-frequency flyback converter using fifth-generation CoolSET™ (V 1.0); 2018-02-26; [Calculation tool fixed-frequency CoolSET™ 5th generation – ICE5xRxxxxxZ](#)

Revision history

Revision history

Document version	Date of release	Description of changes
V 1.0	2022-06-15	First release

Trademarks

All referenced product or service names and trademarks are the property of their respective owners.

Edition 2022-06-15

Published by

Infineon Technologies AG

81726 Munich, Germany

© 2022 Infineon Technologies AG.

All Rights Reserved.

Do you have a question about this document?

Email: erratum@infineon.com

Document reference

AN_2101_PL21_2105_102108

IMPORTANT NOTICE

The information contained in this application note is given as a hint for the implementation of the product only and shall in no event be regarded as a description or warranty of a certain functionality, condition or quality of the product. Before implementation of the product, the recipient of this application note must verify any function and other technical information given herein in the real application. Infineon Technologies hereby disclaims any and all warranties and liabilities of any kind (including without limitation warranties of non-infringement of intellectual property rights of any third party) with respect to any and all information given in this application note.

The data contained in this document is exclusively intended for technically trained staff. It is the responsibility of customer's technical departments to evaluate the suitability of the product for the intended application and the completeness of the product information given in this document with respect to such application.

For further information on the product, technology, delivery terms and conditions and prices please contact your nearest Infineon Technologies office (www.infineon.com).

WARNINGS

Due to technical requirements products may contain dangerous substances. For information on the types in question please contact your nearest Infineon Technologies office.

Except as otherwise explicitly approved by Infineon Technologies in a written document signed by authorized representatives of Infineon Technologies, Infineon Technologies' products may not be used in any applications where a failure of the product or any consequences of the use thereof can reasonably be expected to result in personal injury.