

TE CONNECTIVITY (TE) RESERVES THE RIGHT TO CHANGE THIS DRAWING AT ANYTIME. USERS SHOULD EVALUATE THE SUITABILITY OF THE PRODUCT FOR THEIR APPLICATION.

REVISIONS			
LTR	DESCRIPTION	DATE	APPROVED
D	REVISED PER ECO-12-021589	12/11/2012	G.WELLS
E	REVISED PER ECO-15-018009	12/11/2015	I.MYONG

SCOPE:

THIS SPECIFICATION PROVIDES A DESCRIPTION OF HEAT-TO-RECOVER METAL RINGS FOR TERMINATING BRAIDED SHIELD ONTO ADAPTORS DESIGNED FOR THAT PURPOSE.

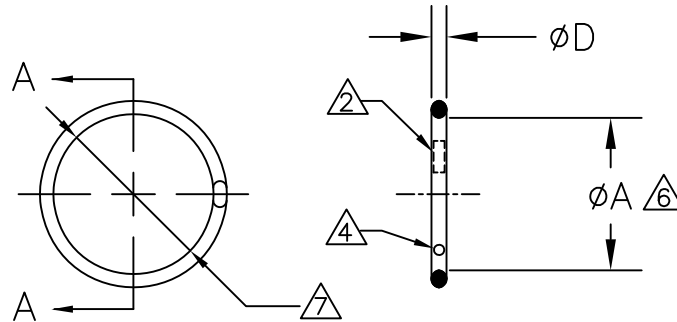

PART DESCRIPTION:

TR	XX	X	I	
			INSULATING LINING	
			BRAID DESIGNATOR	
			A-36 AWG BRAID, 1 LAYER	
			B-36 AWG BRAID, 2 LAYERS	
			B-30 AWG BRAID, 1 LAYER	
			C-32 AWG BRAID, 2 LAYERS	
			REFER TO MSG-101 FOR RING AND BRAID SELECTION	
			RING SIZE (MATCHES TXR ADAPTER ENTRY SIZE)	
			PRODUCT DESIGNATOR	

NOTES: UNLESS OTHERWISE SPECIFIED.

1. MATERIAL: NICKEL/TITANIUM HEAT-TO-RECOVER SHAP MEMORY ALLOY.
2. THE OUTSIDE SURFACE OF THE RING IS MARKED WITH TWO STRIPES OF THERMOCHROMIC PAINT WHICH CHANGE COLOR WHEN THE APPROPRIATE INSTALLATION TEMPERATURE IS REACHED.
3. "AI" RINGS ARE IDENTIFIED BY THE ABSENCE OF A RED OR BLUE DOT. REFER TO NOTE 4 BELOW.
4. "BI" RINGS ARE MARKED WITH A RED DOT. "CI" RINGS ARE MARKED WITH A BLUE DOT.
5. REFER TO MIP-101 FOR INSTALLATION PROCEDURE AND PERFORMANCE REQUIREMENT.
6. AVERAGE OF MEASUREMENTS TAKEN AT 3 POINTS, EQUALLY SPACED ON WELD AND OFF WELD.
7. SHAPE OF THE RING TO BE MOSTLY CIRCULAR. CERTAIN SIZES (LARGER) MAY HAVE MULTIPLE SIDES.

© 2015 TE CONNECTIVITY LTD. FAMILY OF COMPANIES. ALL RIGHTS RESERVED
 TE CONNECTIVITY AND TE CONNECTIVITY (LOGO) ARE TRADEMARKS.
 OTHER LOGOS PRODUCT AND/OR COMPANY NAMES MAY BE TRADEMARKS OF THEIR RESPECTIVE OWNERS.

Raychem Adapters
 CUSTOMER DRAWING

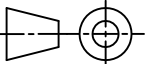
UNLESS OTHERWISE SPECIFIED DIMENSIONS ARE NOT APPLIED.	DRAWN E. GOLDY	DATE 05-17-93	 TE Connectivity			
	REDRAWN T. NGUYEN	DATE 05-17-93				
DECIMAL TOLERANCES .XXX ± -- [mm] .XX ± -- [mm] .X ± -- [mm] ANGLE TOLERANCE .X ± --	APPROVED I. MYONG	DATE 12-08-15	TITLE TINEL-LOCK RING			
	CAD FILE: TR.dwg					
THIRD ANGLE PROJECTION 			SIZE A	CAGE CODE: 06090	DWG. NO. TR	REV: E
			SCALE: NONE		SHEET 1 OF 2	

PART DESCRIPTION	ϕA		ϕD
	MIN AS SUPPLIED	MAX FREE RECOVERED	
TR04AI	.397 [10.08]	.379 [9.63]	.073±.005 [1.85±.13]
TR04BI	.416 [10.57]	.398 [10.11]	.073±.005 [1.85±.13]
TR05AI	.460 [11.68]	.440 [11.18]	.073±.005 [1.85±.13]
TR05BI	.479 [12.17]	.458 [11.63]	.073±.005 [1.85±.13]
TR06AI	.523 [13.28]	.499 [12.68]	.073±.005 [1.85±.13]
TR06BI	.548 [13.92]	.523 [13.28]	.073±.005 [1.85±.13]
TR07AI	.586 [14.88]	.559 [14.20]	.073±.005 [1.85±.13]
TR07BI	.606 [15.39]	.578 [14.68]	.073±.005 [1.85±.13]
TR08AI	.650 [16.51]	.620 [15.75]	.073±.005 [1.85±.13]
TR08BI	.670 [17.02]	.639 [16.23]	.073±.005 [1.85±.13]
TR10AI	.782 [19.86]	.744 [18.90]	.073±.005 [1.85±.13]
TR10BI	.802 [20.37]	.763 [19.38]	.073±.005 [1.85±.13]
TR10CI	.830 [21.08]	.791 [20.09]	.073±.005 [1.85±.13]
TR12AI	.912 [23.17]	.867 [22.02]	.073±.005 [1.85±.13]
TR12BI	.931 [23.65]	.886 [22.50]	.073±.005 [1.85±.13]
TR12CI	.960 [24.38]	.912 [23.17]	.073±.005 [1.85±.13]
TR14AI	1.040 [26.42]	.988 [25.10]	.073±.005 [1.85±.13]
TR14BI	1.060 [26.92]	1.007 [25.58]	.073±.005 [1.85±.13]
TR14CI	1.089 [27.66]	1.033 [26.24]	.073±.005 [1.85±.13]
TR16AI	1.171 [29.74]	1.111 [28.22]	.073±.005 [1.85±.13]
TR16BI	1.191 [30.25]	1.129 [28.68]	.073±.005 [1.85±.13]
TR16CI	1.216 [30.89]	1.154 [29.31]	.073±.005 [1.85±.13]
TR18AI	1.301 [33.05]	1.234 [31.34]	.073±.005 [1.85±.13]
TR18BI	1.320 [33.53]	1.252 [31.80]	.073±.005 [1.85±.13]
TR20AI	1.430 [36.32]	1.357 [34.47]	.073±.005 [1.85±.13]
TR20BI	1.450 [36.83]	1.376 [34.95]	.073±.005 [1.85±.13]
TR22AI	1.543 [39.19]	1.463 [37.16]	.084±.005 [2.13±.13]
TR22BI	1.561 [39.65]	1.481 [37.62]	.084±.005 [2.13±.13]
TR24AI	1.673 [42.49]	1.587 [40.31]	.084±.005 [2.13±.13]
TR24BI	1.691 [42.95]	1.605 [40.77]	.084±.005 [2.13±.18]
TR28AI	1.932 [49.07]	1.838 [46.68]	.084±.005 [2.13±.13]
TR28BI	1.950 [49.53]	1.858 [47.19]	.084±.005 [2.13±.13]

© 2015 TE CONNECTIVITY LTD. FAMILY OF COMPANIES. ALL RIGHTS RESERVED
 TE CONNECTIVITY AND TE CONNECTIVITY (LOGO) ARE TRADEMARKS.
 OTHER LOGOS PRODUCT AND/OR COMPANY NAMES MAY BE TRADEMARKS OF THEIR RESPECTIVE OWNERS.

Raychem Adapters
 CUSTOMER DRAWING

REDRAWN T. NGUYEN	DATE 12-07-2015	SIZE A	CAGE CODE: 06090	DWG. NO. TR	REV: E
CAD FILE: TR-CD		SCALE: NONE			SHEET 2 OF 2