

REQUEST A QUOTE

UPTIME

TRANSCEIVERS

SMART CODER

TECHNICAL SUPPORT

ABOUT

PARTNERS

DATASHEET DOWNLOAD

CHAT WITH AN EXPERT

HIDE

Integra Part #: 346B-10

Product Description

QSFP+, 1310nm, LR4 SMF 10km, 40G DDM, MSA Compatible

Integra manufactures the highest quality **QSFP** transceivers in the industry, designed to be 100% interoperable with all OEM platforms. We're the first optics manufacturer in the Western Hemisphere to invest in high-speed robots, allowing us to scale our operations to handle virtually any order, large or small, and ensure every transceiver is correctly coded and tested 100% of the time.

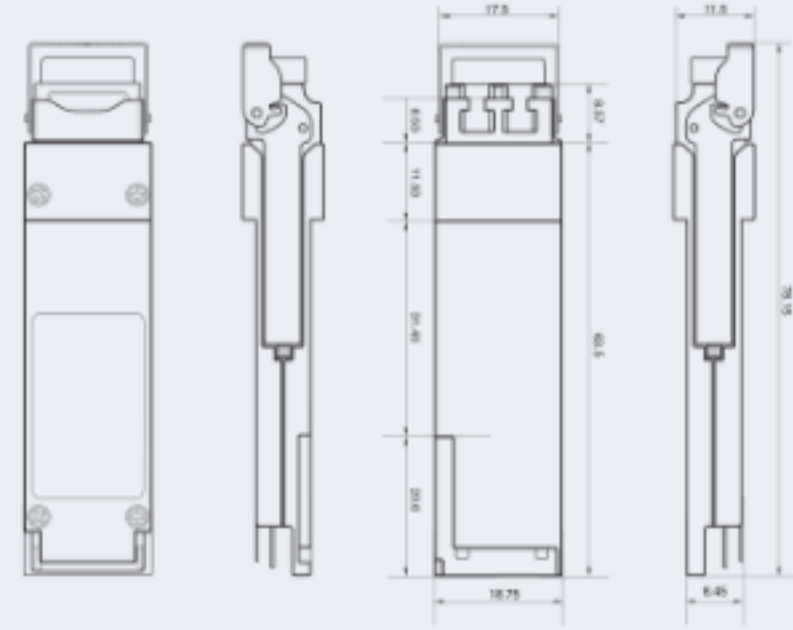

 **DOWNLOAD DATASHEET**

 **REQUEST A QUOTE**

Related Products

If you're interested in this component, you might also want to search for these related products, accessories, or our Smart Coder and Smart Coder Package

Products

- 3C21-IO
- 3C24-IO
- 43F2-IO
- 43F2.100G-IO
- 43F4-IO
- 4BC4-IO

 [View more](#)

Top Accessories

- IFC-CCR125
- OTE-OPM-MCH
- OTE-CPM-18
- OTE-DPM-48-100

Smart Coder



Giving network engineers and field techs the power to quickly and easily reconfigure transceivers in the field for any network hardware.

