

# Motor and Pump Protection Relays

## MPU-32 Series

### Motor Protection Unit



## Description

The MPU-32 series Motor Protection Unit is used to provide current and temperature-based protection, metering, and data-logging for three-phase, low-voltage, medium-horsepower induction motors. This relay is ideal for retrofitting and upgrading obsolete or aging motor protection using existing CTs. The MPU-32 can be programmed using the front-panel operator interface, the TIA-232 port, or an optional communications network. See the PMA Family of Panel Mount Adapter Kits to replace common obsolete relays.

### 1 Motor Protection Unit

- Three ac-current inputs
- Earth-leakage-CT input
- Programmable digital input
- 24 V dc source for digital input
- Programmable 4–20-mA analog output
- Onboard temperature-sensor input
- 100-Ω-Platinum RTD or PTC
- Three programmable output relays

- Local RS-232 communications, optional network communications
- PC-interface software (SE-Comm-RIS)
- 4 line x 20 character backlit LCD display
- Keypad for programming and display selection
- 4 LEDs; 1 user programmable

### 2 Current Input Module (MPU-CIM)

The MPU-CIM Current Input Module is the interface between the MPU-32 relay and the 5-A-secondary, 1-A-secondary, and sensitive current transformers. The MPU-CIM is ordered separately from the MPU-32 and can be surface- or DIN-rail mounted. Wire-clamping terminals are standard, but the MPUCTI is available for those requiring ring-tongue terminals.

## Features & Benefits

FEATURES	IEEE #	BENEFITS
<b>Overload</b>	49, 51	Extends motor life and prevents insulation failures and fires
<b>Dynamic thermal model</b>		Provides protection through starting, running, and cooling cycles
<b>Communications</b>		Remotely view measured values and event records, reset trips, and access setpoints
<b>Ground fault</b>	50G/N, 51G/N	Prevents catastrophic failures and fires
<b>Current unbalance/Phase loss/Phase reverse (current)</b>	46	Prevents overheating due to unbalanced phases
<b>RTD temperature</b>	38, 49	RTD temperature protection (MPS-RTD module) for high-ambient or loss-of-ventilation protection
<b>Phase loss/Phase reverse (current)</b>	46	Detects unhealthy supply conditions
<b>Overcurrent</b>	50, 51	Prevents catastrophic failures and fires and extends motor life
<b>Jam</b>		Prevents motor damage by detecting mechanical jams or excessive loading
<b>Undercurrent</b>	37	Detects low level or no-load conditions
<b>PTC overtemperature</b>	49	Overtemperature (PTC) protection for high-ambient or loss-of-ventilation detection
<b>Starts per hour</b>	66	Limits the motor starts per hour to prevent overheating
<b>Differential</b>	87	Optional MPS-DIF module for sensitive winding-fault protection

# Motor and Pump Protection Relays

## MPU-32 Series

### Applications

- Low and medium voltage motors

### Specifications

#### Protective Functions

##### (IEEE Device Numbers)

Overload (49, 51), Phase reverse (current) (46), Overcurrent (50, 51), Jam, Ground fault (50G/N, 51G/N), PTC overtemperature (49), RTD temperature (38, 49), Unbalance (current) (46), Starts per hour (66), Differential (87), Phase loss (current) (46), Undercurrent (37)

#### Input Voltage

65-265 V ac, 25 VA; 80-275 V dc, 25 W

#### Power-Up Time

800 ms at 120 V ac

#### Ride-Through Time

100 ms minimum

#### 24-Vdc Source

100 mA maximum

#### AC Measurements

True RMS and DFT, Peak, 16 samples/cycle, and positive and negative sequence of fundamental

#### Frequency

50, 60 Hz or ASD

#### Output Contacts

Three Form C programmables

#### Communications

TIA-232 (standard); TIA-485, DeviceNet™, Ethernet (optional)

#### Analog Output

4-20 mA, programmable

#### Conformally Coated

Standard feature

#### Warranty

10 years

#### Control Unit Mounting

Panel (standard), Surface (with MPU-32-SMK converter kit)

#### Current Input Module Mounting

DIN, Surface

### Certification & Compliance

<b>CSA</b>	CSA, Canada and USA (CSA C22.2 No. 14, CSA C22.2 No. 213-M1987 (RTD module only), CSA E60079-15:02 (RTD module only))
<b>CE</b>	EN 60255-26, IEC 61010-1
<b>UL</b>	UL Recognized (UL 508, UL 1053, UL 60079-15 (RTD module only))
<b>RCM</b>	RCM

### Accessories

#### A Phase Current Transformers

Phase CTs are required to detect phase currents. For upgrade applications, existing CTs can be used.

#### B Earth-Fault Current Transformer

Optional zero-sequence current transformer detects ground-fault current. Available with 5-A and 30-A primary ratings for low-level pickup.

#### C MPS-RTD Temperature Input Module

Optional module provides 8 inputs to connect Pt100, Ni100, Ni120, and Cu10 RTDs.

# Motor and Pump Protection Relays

## MPU-32 Series

### Ordering Information

ORDERING NUMBER	COMMUNICATION	PHASE CURRENT TRANSFORMER INPUTS
MPU-32-00-00	TIA-232	Using MPU-CIM-00-00, purchased separately
MPU-32-01-00	TIA-232 & TIA-485	
MPU-32-02-00	TIA-232 & DeviceNet™	
MPU-32-04-00	TIA-232 & EtherNet/IP™ & Modbus® TCP	
MPU-32-00-01	TIA-232	Onboard inputs for 1-A phase CTs
MPU-32-01-01	TIA-232 & TIA-485	
MPU-32-02-01	TIA-232 & DeviceNet™	
MPU-32-04-01	TIA-232 & EtherNet/IP™ & Modbus® TCP	

ACCESSORIES	REQUIREMENT
Phase CTs	Required
Earth-Fault CTs	Optional
MPS-RTD-01-00	
MPU-32-SMK	
CA-945	
MPU-16A-Y92A-96N	

### Simplified Wiring Diagram

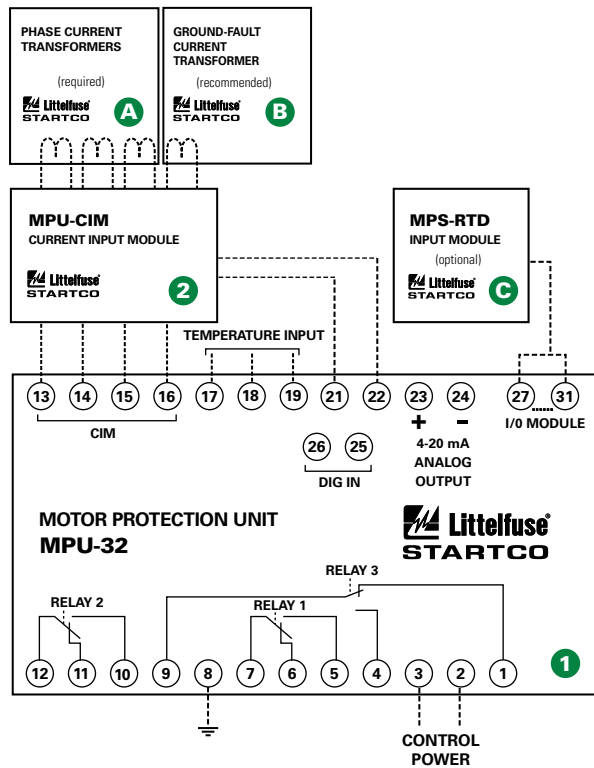

Note: Unit shown with MPU-CIM-00-00 for phase current transformer inputs

### Simplified Circuit Diagram

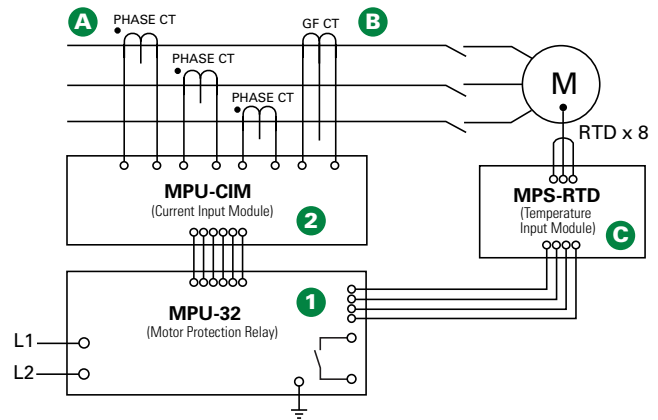

**Disclaimer Notice** – Information furnished is believed to be accurate and reliable. However, users should independently evaluate the suitability of and test each product selected for their own applications. Littelfuse products are not designed for, and may not be used in, all applications. Read complete Disclaimer Notice at [www.littelfuse.com/product-disclaimer](http://www.littelfuse.com/product-disclaimer).