

THIS DRAWING IS UNPUBLISHED. RELEASED FOR PUBLICATION  
 © COPYRIGHT 20 BY TE Connectivity ALL RIGHTS RESERVED.

REVISIONS				
P	LTR	DESCRIPTION	DATE	APVD
19		ADD SHORT LATCH TYPE	05AUG2022	SS
A		RELEASE TO PRODUCTION	23AUG2022	SS
A1		ADD NEW PNs	26AUG2022	SS
A2		NEW PART INTRODUCED	17MAY2023	AD HL

D

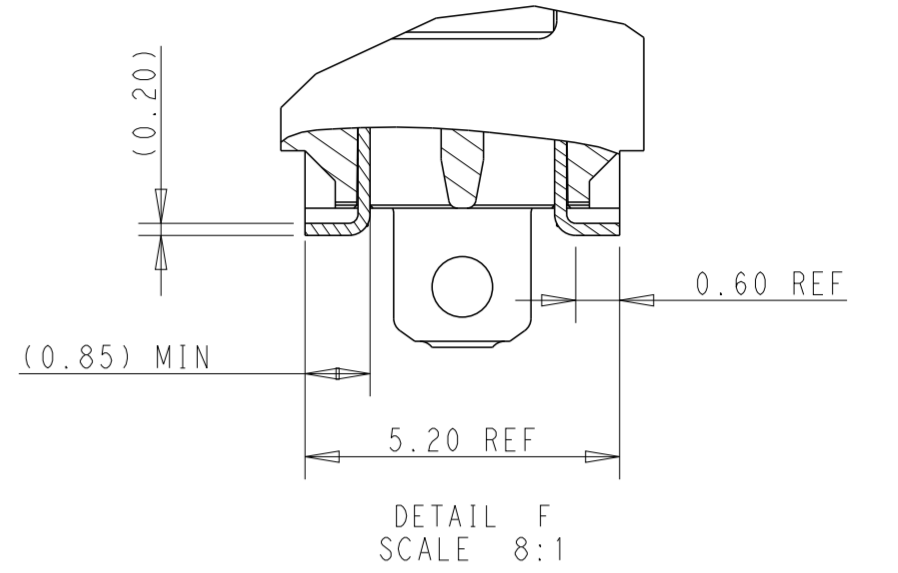
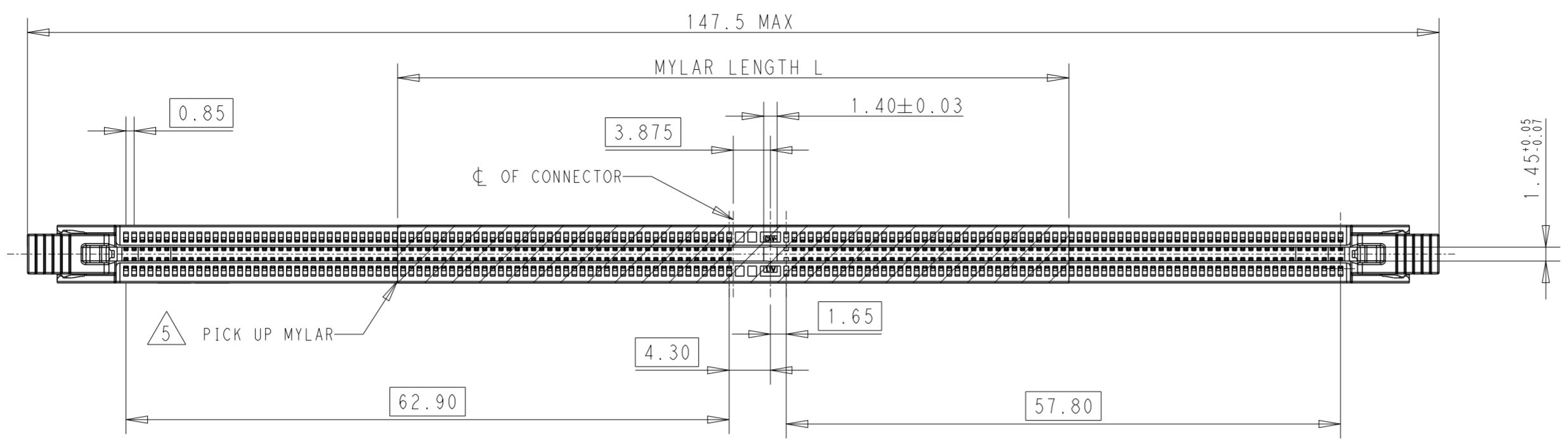

C

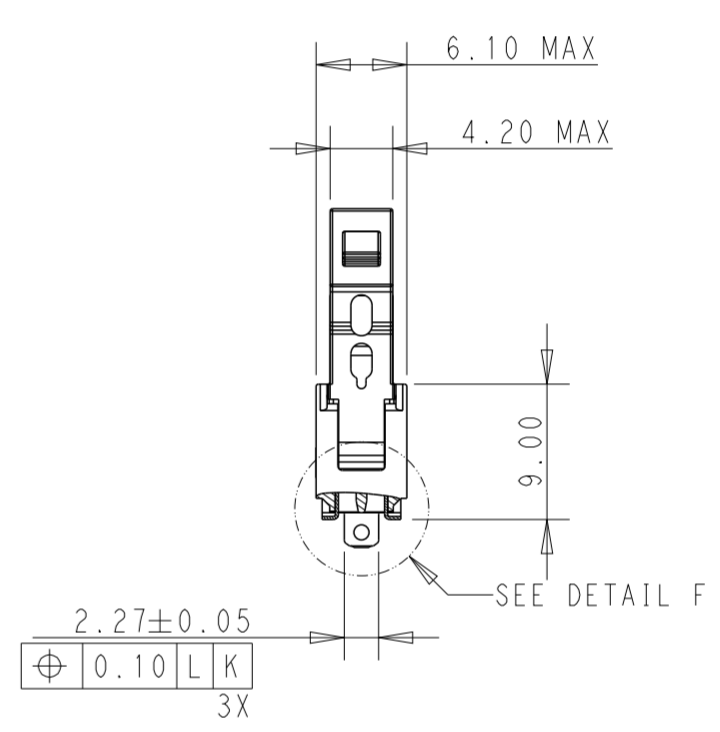
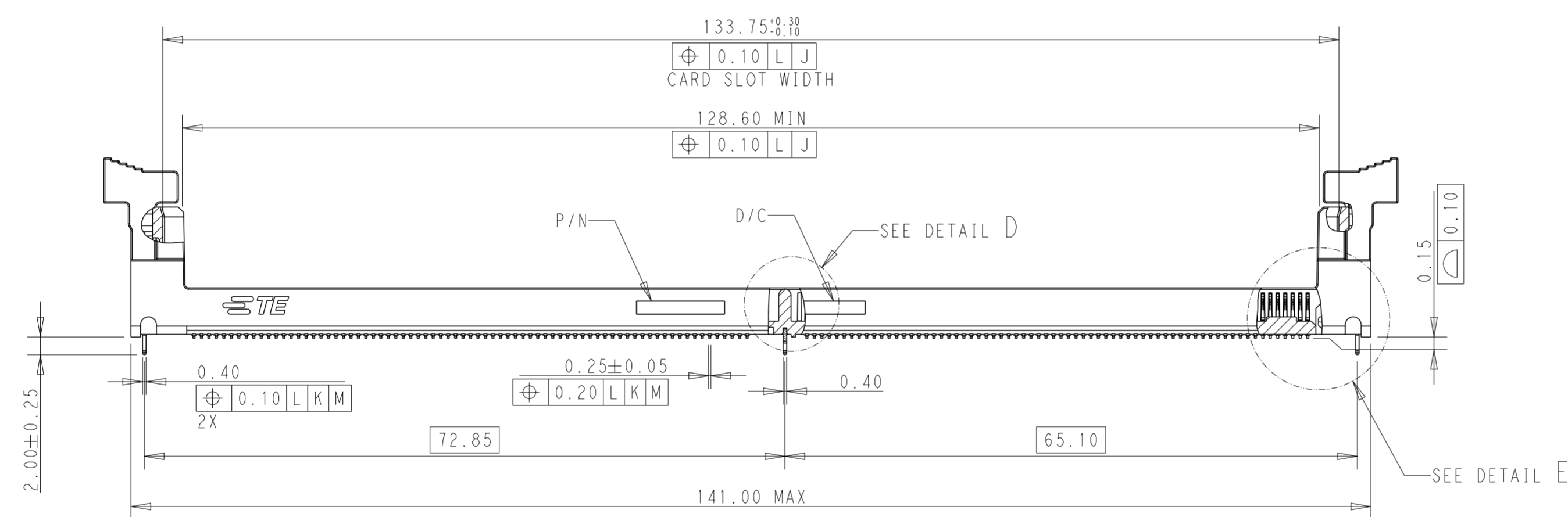

B

- MATERIALS:  
 HOUSING: HIGH TEMPERATURE NYLON, UL 94-V0;  
 LATCHES: HIGH TEMPERATURE NYLON, UL 94-V0;  
 CONTACTS: COPPER ALLOY;  
 HOLD DOWN: STAINLESS STEEL.
- INTERFACE FINISH:  
 (1) 0.00076 (30u") MIN THICK GOLD OVER 0.00127 (50u") MIN THICK NICKEL.  
 (2) 0.00038 (15u") MIN THICK GOLD OVER 0.00127 (50u") MIN THICK NICKEL.
- SOLDERTAIL FINISH:  
 0.00300 (120u") MIN. THICK MATTE TIN OVER 0.00225 (90u") MIN THICK NICKEL.
- HOLD DOWN FINISH:  
 TAB: 0.00300 (120u") MIN MATTE TIN OVER 0.00225 (90u") MIN THICK NICKEL.
- KEEP OUT AREA RESERVED FOR SOCKET LATCHES AT BOTH ENDS.
- MYLAR WITH SIZE L X 6 IS LOCATED IN THE CENTER OF CONNECTOR.

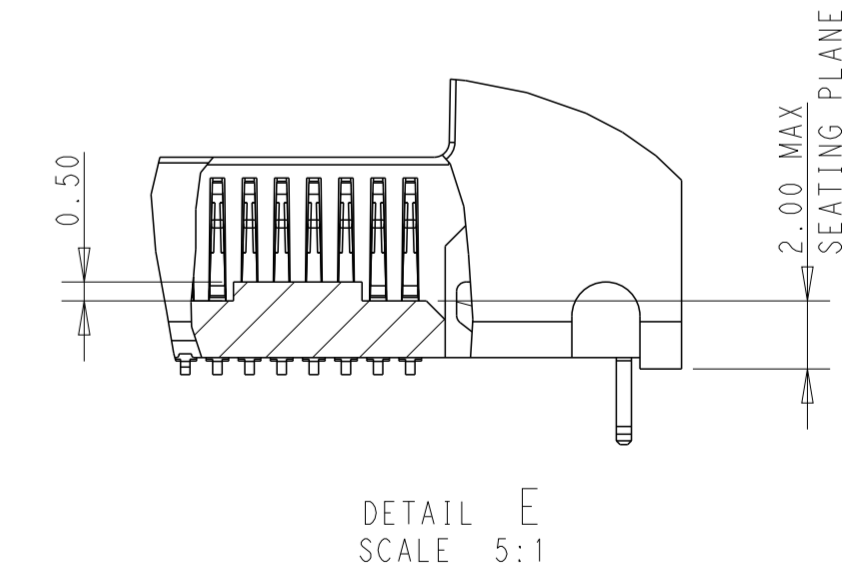
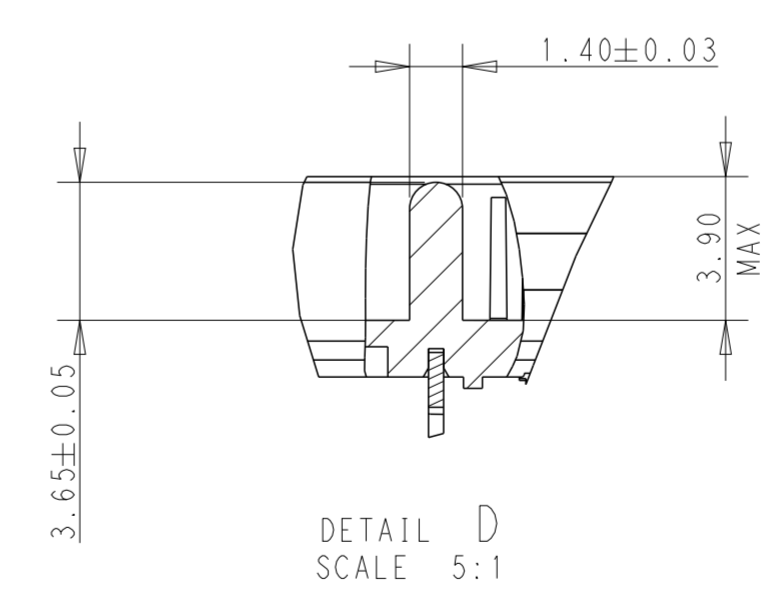

A

THIS DRAWING IS A CONTROLLED DOCUMENT.		DWN 22APR2019 DAVID ZHAO	TE Connectivity	
DIMENSIONS: mm		CHK -		
TOLERANCES UNLESS OTHERWISE SPECIFIED:		PRODUCT SPEC 108-115141		NAME SOCKET ASSEMBLY DDR5 DIMM, SMT NARROW TYPE 0.85MM PITCH, 288 POSITON
0 PLC ± 1 PLC ±0.25 2 PLC ±0.15 3 PLC ±0.10 4 PLC ± ANGLES ±2° FINISH		APPLICATION SPEC 114-115044		
MATERIAL		WEIGHT		SIZE A2 CAGE CODE 00779 DRAWING NO C-2317336
		CUSTOMER DRAWING		RESTRICTED TO
		SCALE 2:1		SHEET 1 OF 6
				REV A2

4

3

2

1

THIS DRAWING IS UNPUBLISHED. RELEASED FOR PUBLICATION  
 © COPYRIGHT 20 BY TE Connectivity ALL RIGHTS RESERVED.

REVISIONS				
P	LTR	DESCRIPTION	DATE	APVD
		SEE SHEET 1		

△ BOARDLOCK AND TAB ARE OPTIONAL FOR DIFFERENT APPLICATION.  
 △ MYLAR AND CAP ARE OPTIONAL FOR DIFFERENT APPLICATION.

THIS DRAWING IS A CONTROLLED DOCUMENT.		DWN DAVID ZHAO 22APR2019	TE Connectivity	
DIMENSIONS: mm		CHK -		
TOLERANCES UNLESS OTHERWISE SPECIFIED:		APVD -	NAME SOCKET ASSEMBLY	
0 PLC	±0.25	PRODUCT SPEC	DDR5 DIMM, SMT NARROW TYPE	
1 PLC	±0.15	APPLICATION SPEC	0.85MM PITCH, 288 POSITON	
2 PLC	±0.10	108-115141	SIZE	CAGE CODE
3 PLC	±0.10	114-115044	A2	00779
4 PLC	±0.10	WEIGHT -	DRAWING NO	RESTRICTED TO
ANGLES	±2°	CUSTOMER DRAWING	G-2317336	-
FINISH	-	SCALE 1:1	SHEET 2 OF 6	REV A2

1471-9 (3/13)

Downloaded from Arrow.com

THIS DRAWING IS UNPUBLISHED. RELEASED FOR PUBLICATION  
 © COPYRIGHT 20 BY TE Connectivity ALL RIGHTS RESERVED.

REVISIONS				
P	LTR	DESCRIPTION	DATE	APVD
		SEE SHEET 1		

# DDR5 DIMM NAMING RULE\_NARROW TYPE

# DDR5 DIMM SPEC CHARACTERISTICS (MORE SPEC,CHECK TE 108-115141)

X - XXXXXXXX - X

HOUSING&LATCH COLOR

VOID: BLACK&BLACK

1: BLACK&NATURAL

2: BLACK&BLUE

3: BLACK&GREEN

4: NATURAL&BLACK

5: NATURAL&NATURAL

6: BLUE&BLUE

7: BLUE&NATURAL

8: BLUE&BLACK

9: YELLOW&NATURAL

BASE NUMBER FOR NARROW TYPE

2317336: LONG LATCH WITH MYLAR

2379513: LONG LATCH WITH CAP

2379514: LONG LATCH W/O CAP&MYLAR

2416055: SHORT LATCH WITH MYLAR

2428508: SHORT LATCH W/O CAP&MYLAR

2461648: SHORT LATCH WITH CAP

GOLD PLATING&HOLDDOWN TYPE

1: 30u"&3 TAB

2: 30u"&3 BOARDLOCK

3: 30u"&2 SIDETAB+1 BOARDLOCK

4: 15u"&3 TAB

5: 15u"& 3 BOARDLOCK

6: 15u"&2 SIDETAB+1 BOARDLOCK

NOTE: MYLAR LENGTH: L=70.0 ±1.0

## 1. MECHANICAL CHARACTERISTICS

- 1.1 INSERTION FORCE OF MODULE TO CONNENTOR: 106.8N MAX.
- 1.2 UNMATING FORCE: 19.77N MIN.
- 1.3 DURABILITY: PERFORM 25 CYCLES MATING AND UNMATING.
- 1.4 INSERTION FORCE OF CONNECTOR TO PCB: 35N MAX.

## 2. ELECTRICAL CHARACTERISTICS

- 1.1 WITHSTANDING VOLTAGE: 500VAC PER EIA-364-20,CONDITION 1.
- 1.2 INSULATION RESISTANCE: 1M OHMS MIN PER EIA-364-21,500VDC.
- 1.3 CURRENT CARRYING CAPABILITY AT 30°C TEMPERATURE: 1A MAX.
- 1.4 CONTACT RESISTANCE(LLCR):  
INITIAL: 20 MILLIOHMS MAX,  
FINAL: THE CHANGE IN LLCR BETWEEN THE READING AFTER STRESS AND THE INITIAL READING SHALL NOT EXCEED 20 MILLIOHMS.

## 3. ENVIRONMENTAL CHARACTERISTICS

- 1.1 TEMPERATURE LIFE: 105°C,120H PER EIA-364-17,METHOD A.
- 1.2 MECHANICAL SHOCK: 50G,11MILLISECONDS,3 DROPS IN EACH OF 6 DIRECTIONS PER EIA-364-27.
- 1.3 VIBRATION: 10 MINUTES PER DIRECTION FOR ALL 3 DIRECTIONS PER EIA-364-28, PROFILE SEE TE 108-115141.
- 1.4 THERMAL SHOCK: -55°C TO 85°C,5 CYCLES IN MATED CONDITION PER EIA-364-32,METHOD A,CONDITIOIN 1.
- 1.5 CYCLIC TEMPERATUREHUMILITY: 24 CYCLES BETWEEN 25°C AT 80% RH AND 65°C AT 50% RH PER EIA-364-31,METHOD III.
- 1.6 THERMAL CYCLING: 500 CYCLES IN MATED CONDITION BETWEEN 15°C AND 85°C.
- 1.7 MIXED FLOWING GAS:  
FOR 15U"AU TYPE, 168H MIN TESTING PER EIA-364-65,CLASS IIA.  
FOR 30U"AU TYPE, 240H MIN TESTING PER EIA-364-65,CLASS IIA.

## 4. REFLOW PROCESS CHARACTERISTICS

MOISTURE SENSITIVITY LEVEL OF PLASTIC MATERIALL IS LEVEL 1, COULD WITHSTAND 260°C,10S LEAD FREE PROCESS ABILITY. RECOMMENDED REFLOW PROFILE IS IN TE 108-115141.

THIS DRAWING IS A CONTROLLED DOCUMENT.		DWN 22APR2019 DAVID ZHAO	<b>STE</b> TE Connectivity	
DIMENSIONS: mm		CHK -		
TOLERANCES UNLESS OTHERWISE SPECIFIED:		PRODUCT SPEC	NAME	
0 PLC ±		108-115141	SOCKET ASSEMBLY	
1 PLC ±0.25		APPLICATION SPEC	DDR5 DIMM, SMT NARROW TYPE	
2 PLC ±0.15		114-115044	SIZE	RESTRICTED TO
3 PLC ±0.10		WEIGHT	A2	-
4 PLC ±		CUSTOMER DRAWING	CAGE CODE	DRAWING NO
ANGLES ±2°		SCALE	00779	2317336
FINISH		SHEET	1:1	3 OF 6
		REV	A2	

THIS DRAWING IS UNPUBLISHED. RELEASED FOR PUBLICATION  
 © COPYRIGHT 20 BY TE Connectivity ALL RIGHTS RESERVED.

REVISIONS				
P	LTR	DESCRIPTION	DATE	APVD
		SEE SHEET 1		

1 DATUM Z IS THE TOP SIZE OF PCB.  
 2 HOLD DOWN HOLE SHOULD BE PLATED THROUGH HOLE.

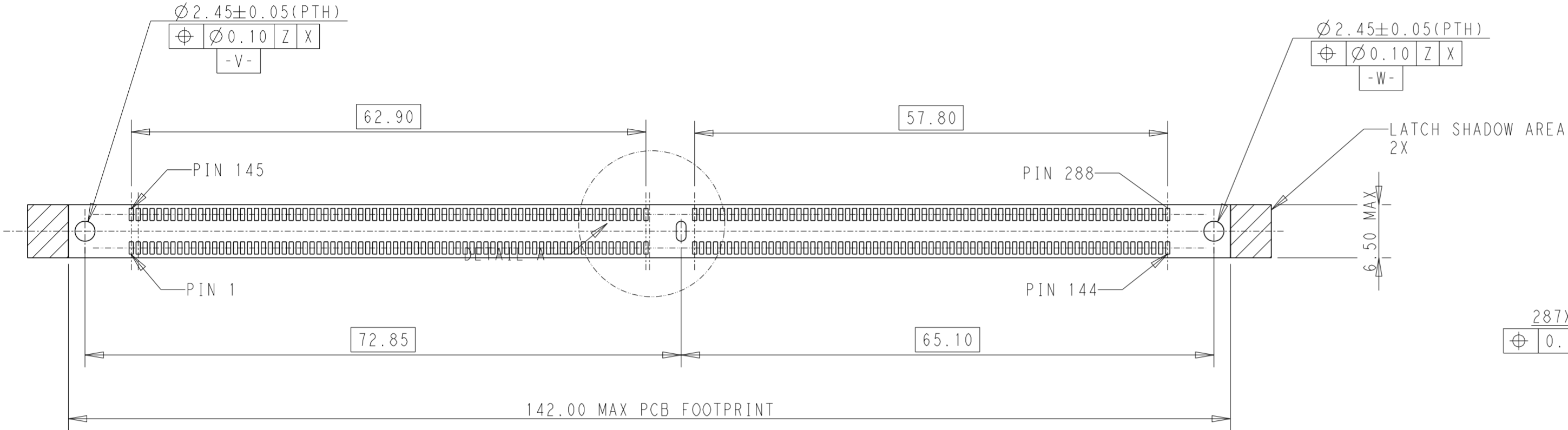

OPTION 1

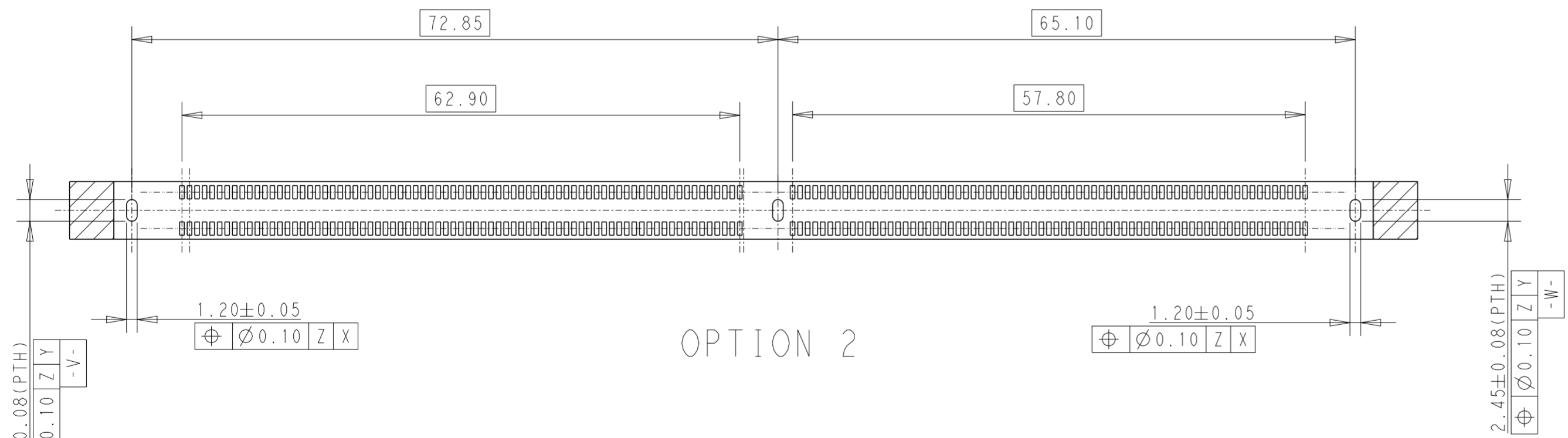

OPTION 2

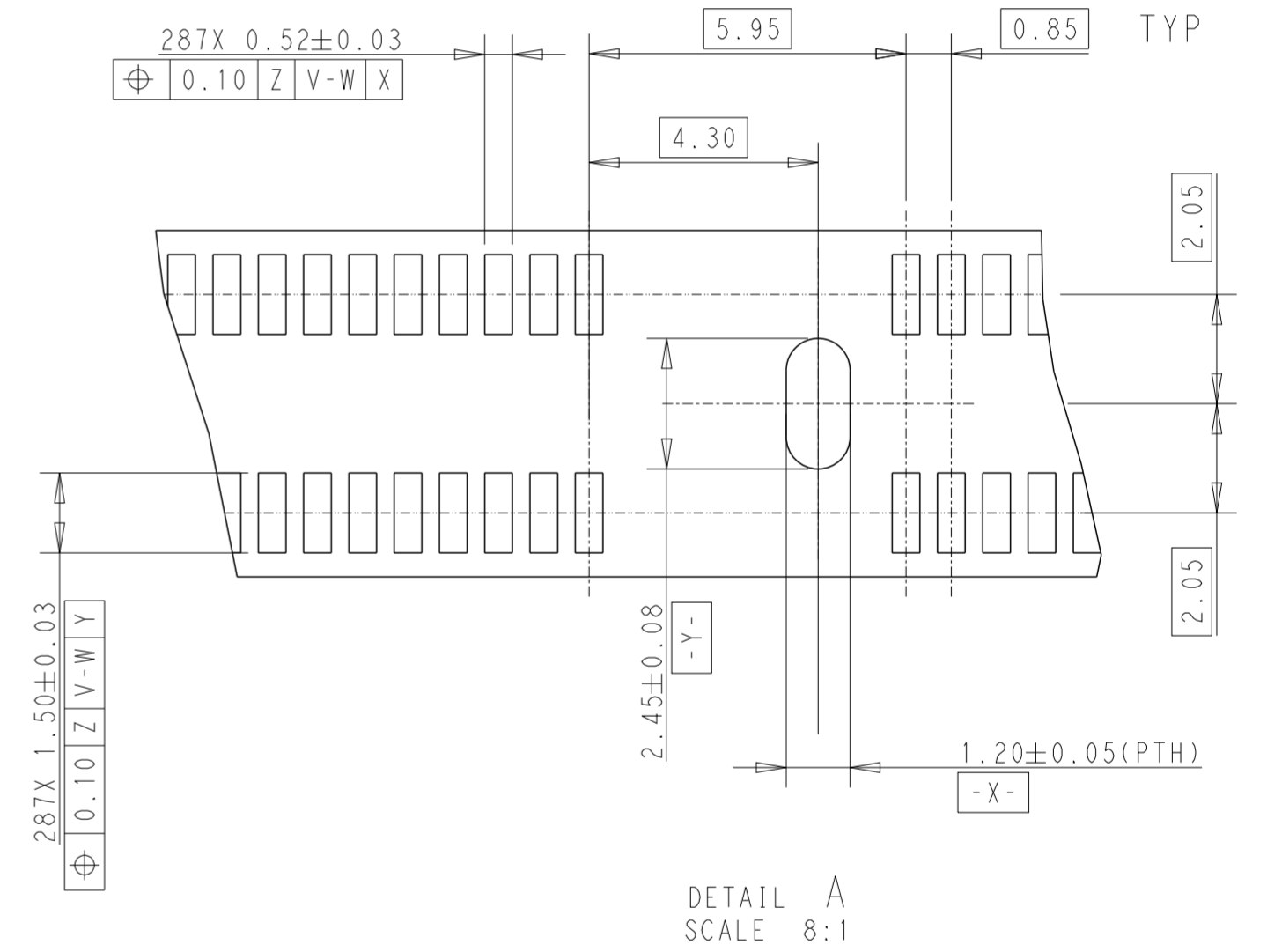

DETAIL A  
SCALE 8:1

RECOMMENDED PCB LAYOUT  
 VIEWED FROM CONNECTOR SIDE

THIS DRAWING IS A CONTROLLED DOCUMENT.		DWN 22APR2019 DAVID ZHAO	TE Connectivity	
DIMENSIONS: mm		CHK -		
TOLERANCES UNLESS OTHERWISE SPECIFIED:		PRODUCT SPEC 108-115141		NAME SOCKET ASSEMBLY
0 PLC ±		APPLICATION SPEC 114-115044		DDR5 DIMM, SMT NARROW TYPE
1 PLC ±0.25		WEIGHT -		0.85MM PITCH, 288 POSITIOIN
2 PLC ±0.15		CUSTOMER DRAWING		RESTRICTED TO -
3 PLC ±0.10		SCALE 1:1		SHEET 4 OF 6
4 PLC ±		SHEET 4 OF 6		REV A2
ANGLES ±2°		FINISH -		

THIS DRAWING IS UNPUBLISHED. RELEASED FOR PUBLICATION  
 © COPYRIGHT 20 BY TE Connectivity ALL RIGHTS RESERVED.

REVISIONS				
P	LTR	DESCRIPTION	DATE	APVD
		SEE SHEET 1		

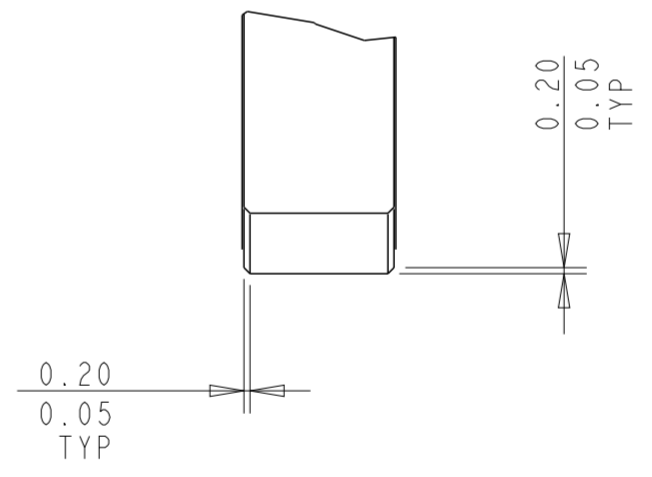
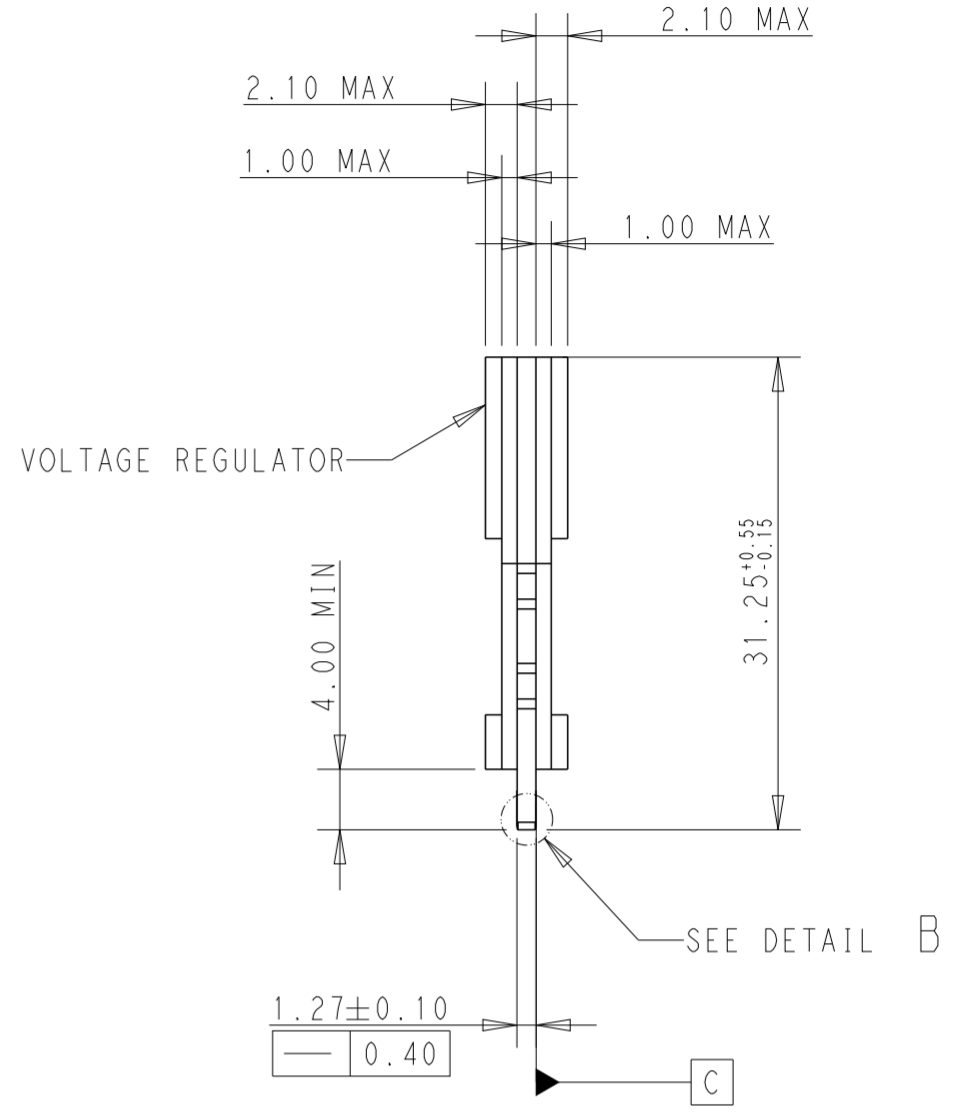
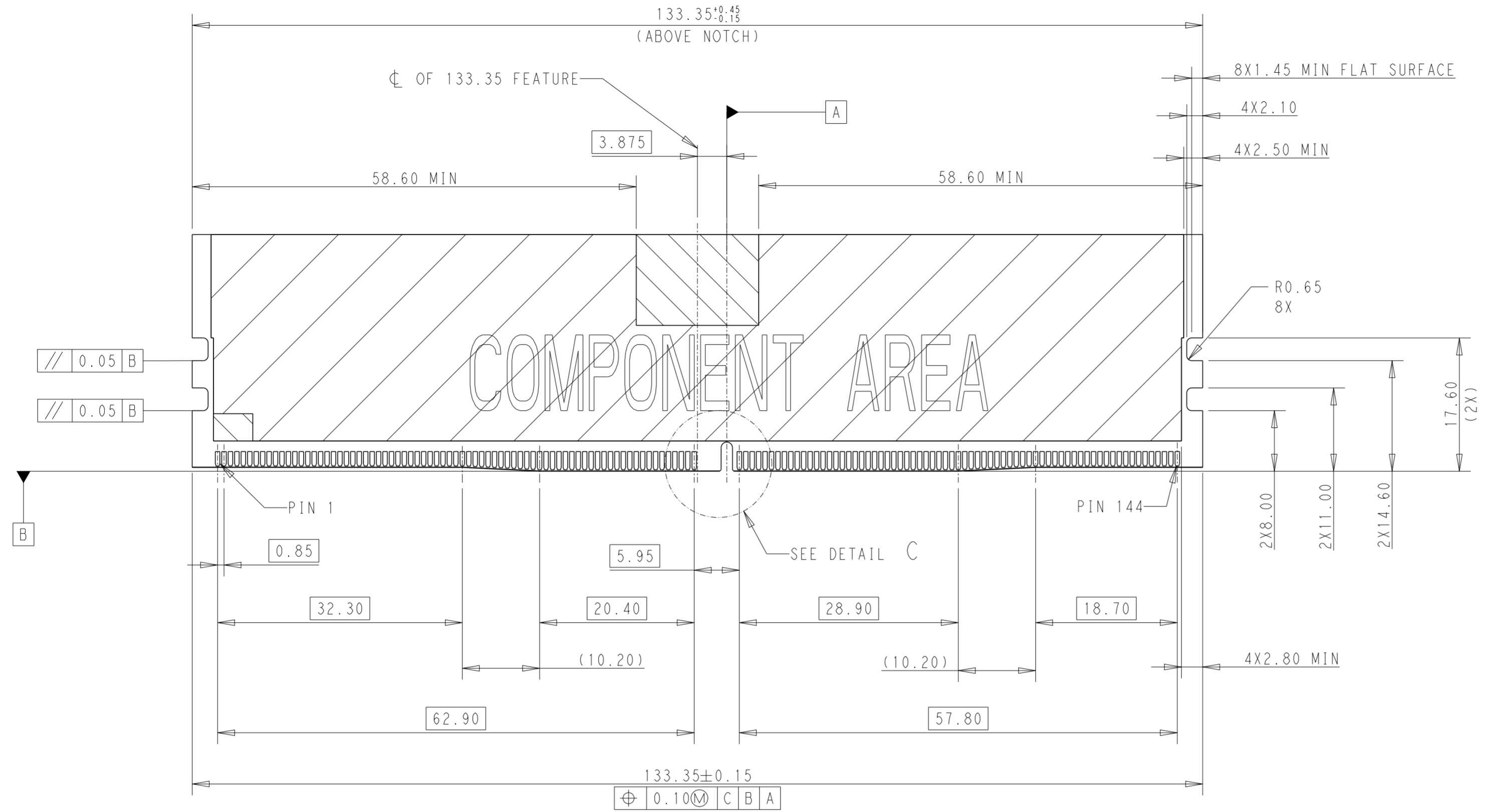

DETAIL B  
SCALE 16:1

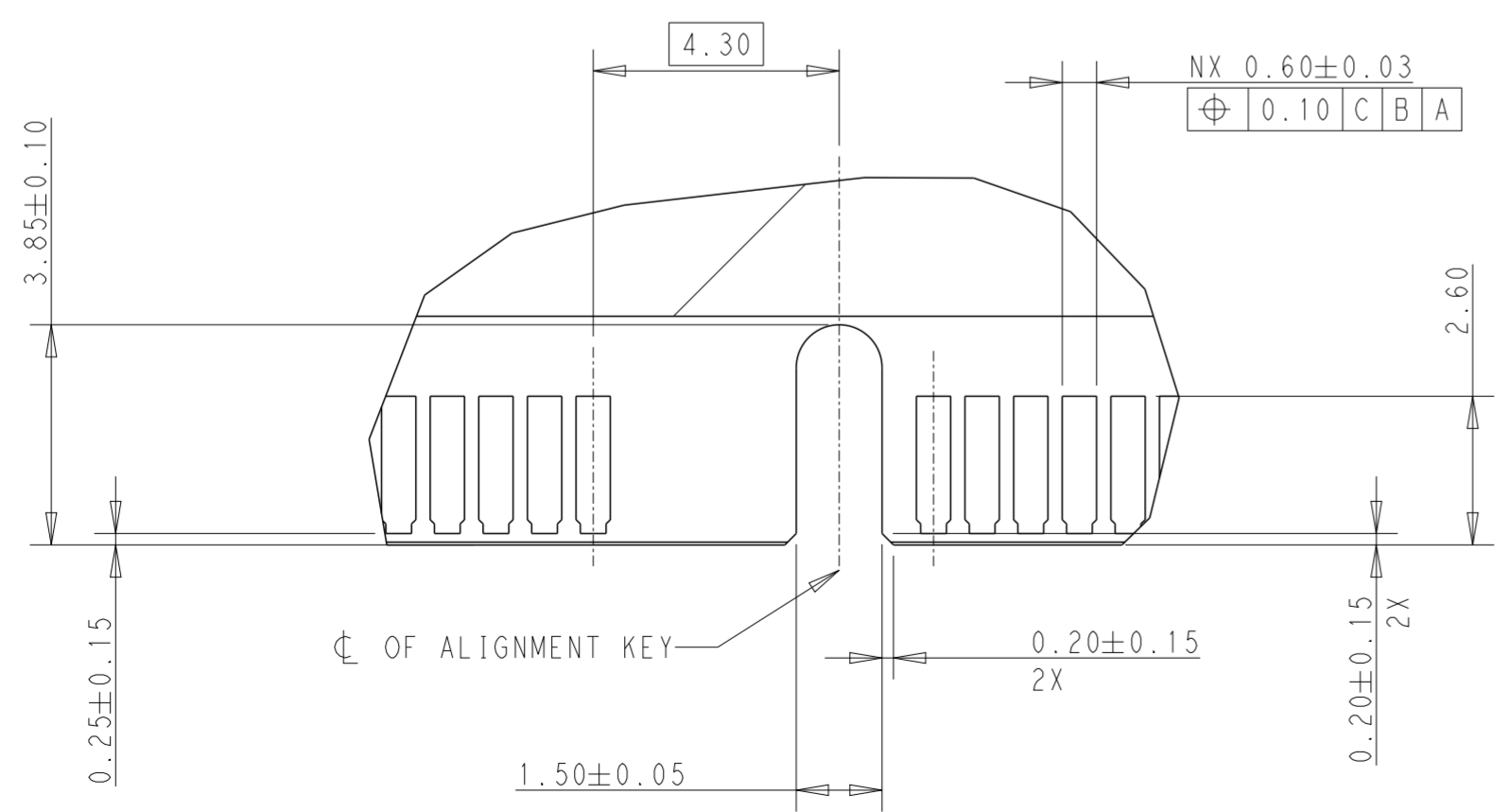

DETAIL C  
SCALE 8:1

THIS DRAWING IS A CONTROLLED DOCUMENT.		DWN DAVID ZHAO 22APR2019	TE Connectivity	
DIMENSIONS: mm		CHK -		
TOLERANCES UNLESS OTHERWISE SPECIFIED:		APVD -	NAME SOCKET ASSEMBLY	
0 PLC ±	1 PLC ±0.25	PRODUCT SPEC 108-115141	DDR5 DIMM, SMT NARROW TYPE	
2 PLC ±0.15	3 PLC ±0.10	APPLICATION SPEC 114-115044	0.85MM PITCH, 288 POSITIOIN	
4 PLC ±	ANGLES ±2°	WEIGHT -	SIZE A2	CAGE CODE 00779
MATERIAL -	FINISH -	CUSTOMER DRAWING	DRAWING NO C-2317336	RESTRICTED TO -
SCALE 1:1			SHEET 5 OF 6	REV A2

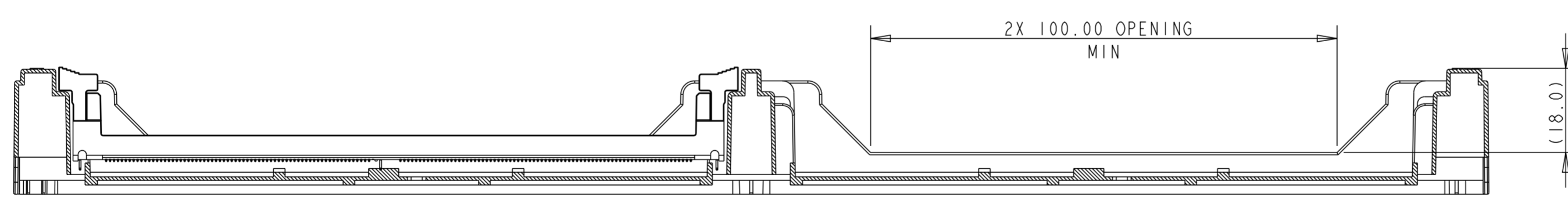
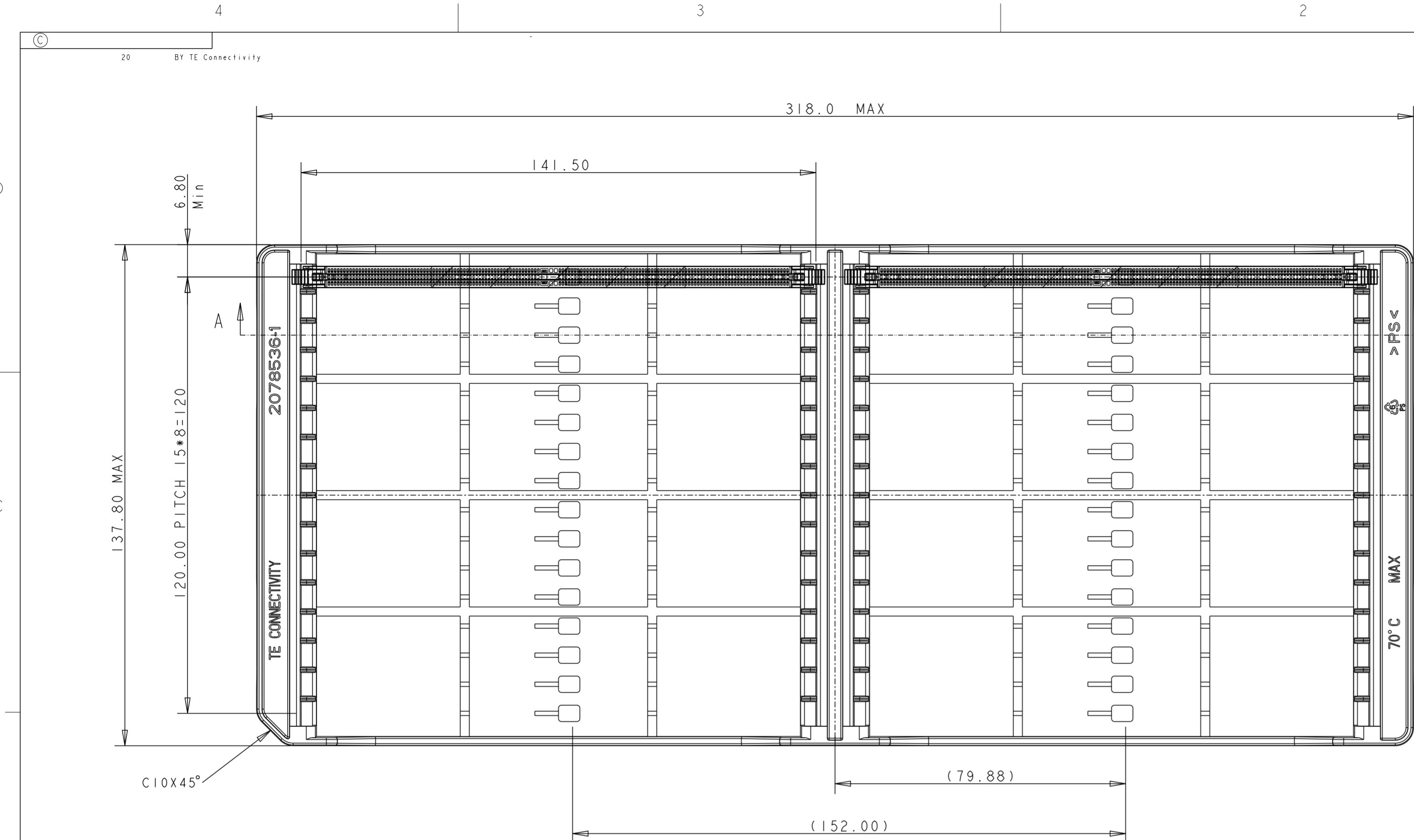

SECTION A-A

REVISIONS					
P	LTR	DESCRIPTION	DATE	DWN	APVD
		SEE SHEET 1			

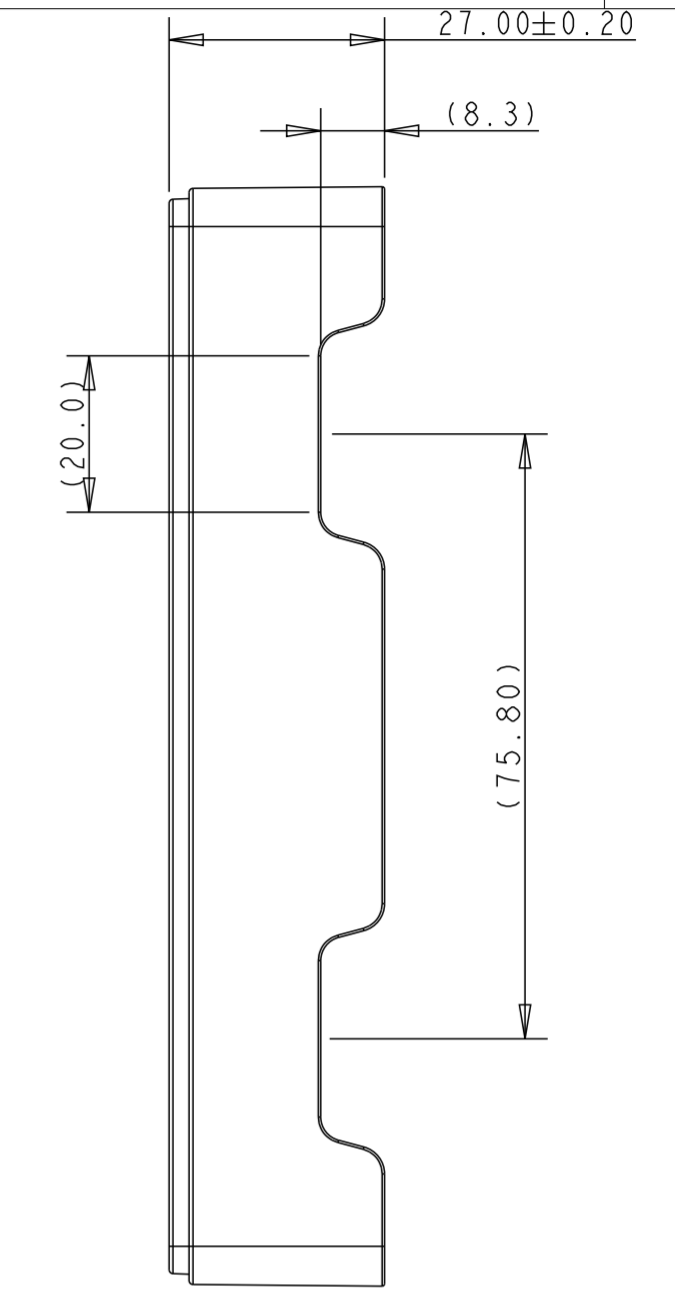

- NOTES:
- MATERIALS :  
TRAY: HIPS, COLOR: BLACK  
BOX: CORRUGATED FIBERBOARD
  - DIMENSIONS:  
BOX: L=410;W=383;H=340
  - QUANTITY:  
32 PCS/TRAY  
640 PCS/BOX
  - WEIGHT:  
GROSS WEIGHT: 7.5KG

THIS DRAWING IS A CONTROLLED DOCUMENT.		DWN DAVID ZHAO 22APR2019	TE Connectivity		
DIMENSIONS: mm		CHK -			
TOLERANCES UNLESS OTHERWISE SPECIFIED: 0 PLC ± 1 PLC ±0.25 2 PLC ±0.15 3 PLC ±0.10 4 PLC ± ANGLES ±2° FINISH -		APVD -	NAME SOCKET ASSEMBLY DDR5 DIMM, SMT NARROW TYPE 0.85MM PITCH, 288 POSITON		
MATERIAL -		PRODUCT SPEC 108-115141	SIZE A2	CAGE CODE 00779	DRAWING NO C-2317336
		APPLICATION SPEC 114-115044	RESTRICTED TO -		
		WEIGHT -	SCALE 1:1 SHEET 6 OF 6 REV A2		
		CUSTOMER DRAWING			