



Shoes/Wrist Strap Tester 747

Data Logging Software 747DLS

Daily inspection and recording of wrist strap and shoe testing is very important as a fundamental countermeasure against static on personnel. A fully functional resistance tester, the new 3M™ Shoes/Wrist Strap Tester 747 makes it possible to control both in a single unit. Use of the external data port allows automatic recording of test results, eliminating manual recording and possible errors.

Features

Checks personnel wearing wrist straps, ESD shoes and heel straps against preset resistance limits

Actual measurement results are indicated on a 3½ digit display and by LED lamps

Test results available on RS-232C Serial Port and output jack

Testing data automatically recorded when utilizing the 3M™ Data Logging Software 747DLS

ESD Shoes & Heel Strap Testing

- Electrical resistance of ESD shoes and heel straps is measured and compared to preset limits.
- Set value for the upper and lower resistance limits can be varied. Upper limit: 10M ohms, 35M ohms, or 100M ohms. Lower limit: 100k ohms (1.0M ohms).
- LCD display (3½ digit) indicates actual resistance measurement value.*
- LED's on the tester indicate Low, OK, and High test results.
- Measurement requires standing on the Shoe Testing Plate and pressing the touch panel.

*Includes body resistance

Wrist Strap Testing

- Electrical resistance of wrist straps is measured and compared to preset limits.
- Set value for an upper resistance limit can be varied. (5M ohms, 10M ohms and 35M ohms). Lower resistance limit 650K ohms preset internally.
- LCD display (3½ digit) indicates actual resistance measurement value.**
- LED's on the tester indicate (Low, OK and High) test results.
- The measurement requires inserting ground cord plugs into a test jack and pressing the touch panel.

**Includes arm to wrist band contact resistance



External Output Functions

- RS-232C Serial Data Port provides resistance value and pass/fail test result information for computer data logging. Used with 3M Data Logging Software 747DLS.
- Open collector output configuration provides High and Low signal levels for pass/fail test result indication. When used with an external relay door entries can be controlled.

3M™ Shoes/Wrist Strap Tester 747

Product Specifications

Environmental Operating Conditions	Temperature range 0° to 40°C 80% Relative Humidity
Power Supply	AA (LR6) alkaline battery (1.5 VDC x 6) or AC adapter (9 VDC, center positive)
Size	7.7"H x 4.7"W x 1.89"D (196 mm x 120 mm x 48 mm)
Weight	1.2 lb (550 g without batteries)

3M™ Data Logging Software 747DLS

Designed to work with the 3M Shoes/Wrist Strap Tester 747, the Data Logging Software 747DLS offers you a complete system of testing and recording results of your wrist straps and footwear. Our complete system performs an accurate resistance measurement of either or both your wrist straps and footwear. Once completed, the results will then be automatically saved on a PC which allows efficient data storage and faster data retrieval.

The software communicates via RS232 signal to a personal computer and can handle up to 8 stations using a single PC. Longer distances of up to 4000 ft. (1200 m) can also be accommodated.

Features	Benefits
Electronic data logging	Eliminates manual logging thus provides highly reliable record
Can accommodate up to 8 stations	Cost efficient
Identification card compatibility	Can be used with bar code, magnetic stripe or proximity card readers/identification cards
Can be used for up to 4000 ft. (1200m)	Can serve almost an entire facility
Incorporates a pilot lamp in monitoring	Identifies which testing stations are currently being used
Printable records	Hard copies can be kept for documentation

PC System Requirements

Windows™ 95, 98 2nd Edition, 2000 with Service Pack 2 and Millenium Edition. Pentium 133 MHz; 32 MB RAM; 26 MB Hard Disk Space; 800x600 True Color 32 Bit Display. Single Station Operation - Requires two communication ports available (COM1 & COM2) Multiple Station Operation - Requires one PCI available slot, two is recommended for full eight-station operation.

3M is a trademark of 3M Company
Windows is a trademark of Microsoft

Important Notice

All statements, technical information, and recommendations related to 3M's products are based on information believed to be reliable, but the accuracy or completeness is not guaranteed. Before using this product, you must evaluate it and determine if it is suitable for your intended application. You assume all risks and liability associated with such use. Any statements related to the product which are not contained in 3M's current publications, or any contrary statements contained on your purchase order shall have no force or effect unless expressly agreed upon, in writing, by an authorized officer of 3M.

Distributed by:

All-Spec Industries

www.all-spec.com
sales@all-spec.com

PH: 800-537-0351
FX: 800-379-9903

Card Reader Technical Requirements

Serial Interface Specification:

Bit Rate - 110, 300, 1200, 2400, 4800, 9600, 19200, 38400, 57600, 115200 (selectable)

Word Length:

Data Format - 4, 5, 6, 7, 8 (selectable)

Parity Bit - Even, Odd, None, Mark, Space (selectable)

Stop Bit - 1, 1.5, 2 (selectable)

Handshaking (Flow Control) - None, Xon/Xoff, RTS/CTS, RTS/XonXoff (selectable)

Magnetic Card Reader Data:

Message Indicator

Start of Text - Single ASCII character

End of Text - Single ASCII character

Track Framing Characters

Track 1 Start - Single ASCII character

Track 1 End - Single ASCII character

Track 2 Start - Single ASCII character

Track 2 End - Single ASCII character

Track 3 Start - Single ASCII character

Track 3 End - Single ASCII character

Barcode Reader Data:

Message Indicator

Start of Text - Single ASCII character

End of Text - Single ASCII character

Proximity Card Reader Data:

Start of Text - Two ASCII character

End of Text - CR, LF, CR/LF (selectable)

Warranty; Limited Remedy; Limited Liability.

This product will be free from defects in material and manufacture for a period of 1 year from the date of purchase. **3M MAKES NO OTHER WARRANTIES INCLUDING, BUT NOT LIMITED TO, ANY IMPLIED WARRANTY OF MERCHANTABILITY OR FITNESS FOR A PARTICULAR PURPOSE.** If this product is defective within the warranty period stated above, your exclusive remedy shall be, at 3M's option, to replace or repair the 3M product or refund the purchase price of the 3M product. **Except where prohibited by law, 3M will not be liable for any loss or damage arising from this 3M product, whether direct, indirect, special, incidental or consequential regardless of the legal theory asserted.**



Minimum 10%
Post-consumer fiber

Printed in USA.

© 3M 2003 98-0799-0763-4 (0535) XX-1

3M

Shoes & Wrist Strap Tester 747

Instructions

Contents

Introduction.....	i
Inspection	i
Safety Notes	ii
Notes on Use.....	iii
Chapter 1.0 Overview	1
1.1 Product Outline	1
1.2 Part Names and Functions	2
1.2.1 Front Panel	2
1.2.2 Side Panels.....	3
1.2.3 Back Side	4
Chapter 2.0 Preparation Before Testing	5
2.1 Connecting the ESD Shoe Testing Plate	5
2.2 Threshold Resistance Settings	6
2.3 Power Preparation	7
2.3.1 Installing and Replacing the Batteries	7
2.3.2 AC Adapter Connection	8
2.4 Turning Power On and Off	9
2.5 Wall Mounting	10
Chapter 3.0 Testing	11
3.1 ESD Shoe Testing	12
3.2 ESD Wrist Strap Testing	13
Chapter 4.0 External Output Function	14
4.1 Open Collector Output	14
4.2 RS-232C Communications	16
4.3 Card Read Technical Specifications.....	17
4.4 PC System Requirements	17
Chapter 5.0 Specifications	18
5.1 Measurement Section	18
5.2 General Specifications	19
Chapter 6.0 Maintenance & Service	20
6.1 Battery Replacement Indicator	20
6.2 Error Messages	20
6.3 Before Returning the Tester for Service	21
6.4 Service	21
6.5 Cleaning	21
Chapter 7.0 Operational Verification Test of 3M™ Shoes & Wrist Strap Tester 747	22

Introduction

Thank you for purchasing this 3M™ Shoes & Wrist Strap Tester 747. To get the maximum performance from the unit, please read this manual first, and refer to it as needed.

Inspection

The AC adapter provided with the 3M Shoes & Wrist Strap Tester 747 varies according to region. In North America, the tester is provided with the SA10-0910N AC adapter, while in Europe it is provided with the SA10-0910G AC adapter. Before using the tester, make sure that you have the correct AC adapter for your region.

When the unit is delivered, check and make sure that it has not been damaged in transit. In particular, check the accessories, panel switches, and connectors. If the unit is damaged, or fails to operate according to the specifications, contact your dealer or 3M representative.

Accessories

AC Adapter	1
ESD Shoe Testing Cord	1
Wall-Mounting Board	1
CD Containing Data Logging Software and Operating Instructions	1
ESD Shoe Testing Plate	1
Mounting Screw for ESD Shoe Testing Plate (w/washer)	1
LR6 Alkaline Battery	6
Null Modem Cable 1,8m	1
Quick Guide Test Card	1

Safety Information

Read, understand and follow all safety information before operating this equipment. Retain this Instruction Manual for future reference.

Intended Use

The 3M™ Static Control Shoes/Footwear & Wrist Strap Tester 747 is a single-unit instrument designed especially to measure electrical resistance for evaluating the effectiveness of ESD (electrostatic discharge) shoes and wrist straps used to protect static sensitive devices during handling.

Explanation of Safety Label Signal Words and Symbols Used on Tester

Warning: Indicates a potentially hazardous situation, which if not avoided, may result in death or serious injury.

Caution: Indicates a potentially hazardous situation, which, if not avoided, may result in minor or moderate injury and/or property damage.

 **Warning: Read Accompanying Documentation**

 **Caution: Read Accompanying Documentation**

 Indicates the ON side of the power switch.

 Indicates the OFF side of the power switch.

 Indicates DC (Direct Current).

 Power input connector polarity (center positive)

 See user instruction manual for explanation of indicator lamps



Warning

To reduce the risks associated with an explosion hazard, which, if not avoided, could result in death or serious injury:

- Do not use in an explosive environment. Tester is not designed to be intrinsically safe.

To reduce the risks associated with a medical device malfunction, which, if not avoided, could result in death or serious injury:

- Persons with heart pacemaker devices should never use this tester.



Caution

To reduce the risks associated with hazardous voltage, which, if not avoided, may result in minor or moderate injury and/or property damage:

- AC adapter must have all local required regulatory certifications.
- Do not use AC adapter and/or power cord if damaged.
- When replacing batteries, turn the power switch off and disconnect all the cables before beginning.
- Do not use in an outdoor and/or wet environment.
- Not intended to be serviced by the user. No user serviceable parts.
- Always replace battery cover before using the tester.

To reduce the risks associated with electrostatic discharge (ESD), which, if not avoided, may result in property damage to electronic components or assemblies being handled.

- Perform operational verification test to ensure proper operation of the tester as required.

To reduce the risk associated with environmental contamination, which, if not avoided, may result in-contamination of land, water or air:

- Dispose of tester and/or batteries in accordance with governmental regulations at the end of product-life.

1.0 Overview

1.1 Product Outline



Warning

To reduce the risks associated with an explosion hazard, which, if not avoided, could result in death or serious injury:

- Do not use in an explosive environment. Tester is not designed to be intrinsically safe.

To reduce the risks associated with a medical device malfunction, which, if not avoided, could result in death or serious injury:

- Persons with heart pacemaker devices should never use this tester.

The 3M™ Static Control Shoes & Wrist Strap Tester 747 features:

- (1) **Evaluation of electrostatic protection provided by ESD shoes and wrist straps**
A single device measures the electrical resistance of a body while wearing ESD shoes and wrist straps.
- (2) **Quick Measurements**
Displays measured value and test results, and makes test results available for output within one second after starting measurement.
- (3) **Power Saver Function**
Conserves power by automatically turning off (or entering stand-by state during AC operation) ten seconds after completing a measurement.
- (4) **Test Result Display and Output**
Displays OK, HIGH or LOW test results on panel LEDs. Testing threshold resistance values are set by simple switch selections. Results are also available at an open-collector output terminal. Refer to Section 4.1, “Open Collector Output.”
- (5) **RS-232C Interface**
Test results are available to an external PC through a serial (RS-232C) interface. Refer to Section 4.2, “RS-232C Communications.”

1.2 Part Names and Functions

1.2.1 Front Panel

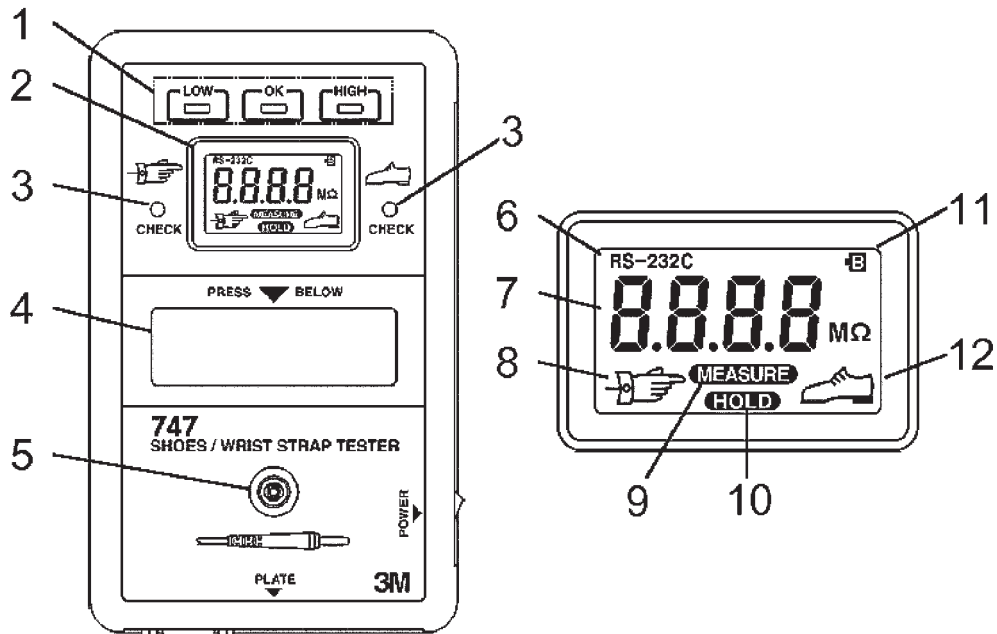

- | | |
|--------------------------|---|
| 1. Test Result LEDs | Indicates test results according to specified threshold resistance. |
| 2. LCD | Shows measurement values and test location status. |
| 3. Test Location LEDs | Indicate the test location and status. |
| 4. Touch Panel | The touch panel is the measurement terminal.
(power switch and Touching the panel initiates testing of the ESD measurement terminal) shoes or wrist strap. |
| 5. Wrist Strap Connector | Connect the wrist strap cable here for wrist strap testing. |

LCD Indicators

- | | |
|------------------------|--|
| 6. RS-232C Indicator | Indicates serial communication is enabled. |
| 7. Measurement Display | The measured value, decimal point and units are displayed. |
| 8. Wrist Strap Symbol | Indicates an ESD wrist strap is being tested. |
| 9. MEASURE Indicator | Indicates a test (measurement) is in progress. |
| 10. HOLD Indicator | Indicates a test is finished. |
| 11. Battery Symbol | Appears when the battery is depleted and needs to be replaced. |
| 12. Shoe Symbol | Indicates ESD shoes are being tested. |

1.2.2 Side Panels

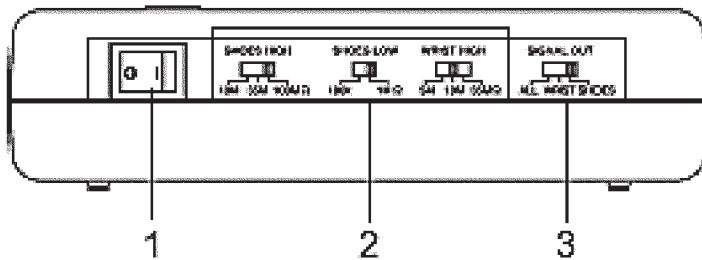

- | | |
|--|--|
| 1. Power Switch | Turns the tester on and off. |
| 2. Threshold Resistance Selection Switches | Select the threshold resistances for shoe and wrist strap tests. |
| 3. Test Result Output Selection Switch | Selects which test results are present at the OUTPUT terminal. |

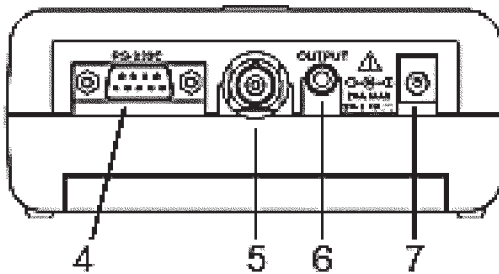

- | | |
|-------------------------------------|--|
| 4. RS-232C Connector | Connect to a PC serial port using an RS-232C cable to transfer data. |
| 5. ESD Shoe Testing Cable Connector | Connect the supplied cable for shoe testing. The other end of this cable connects to the shoe testing plate. |
| 6. Test Result OUTPUT Jack | Test results are available from this open-collector output. |
| 7. AC Adapter Input Jack | The supplied AC Adapter is connected here. Input voltage is 9 VDC, center positive. |

1.2.3 Back Side

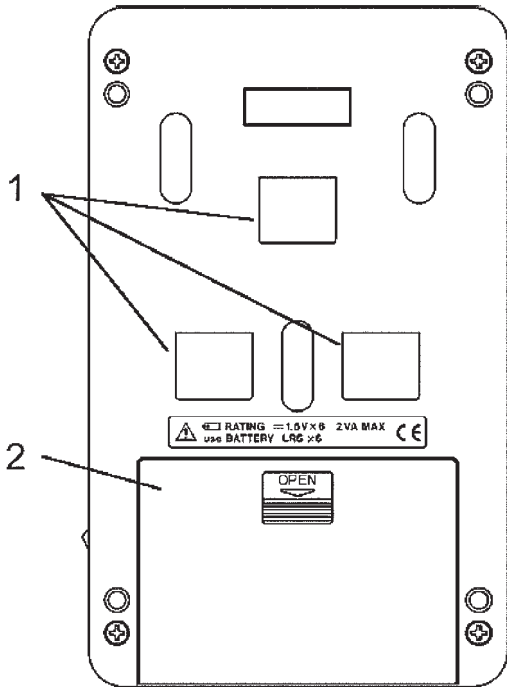

- | | |
|-------------------|---|
| 1. Mounting Holes | These holes accommodate the hooks on the supplied wall-mount board for wall mounting. |
| 2. Battery Cover | To operate from batteries, install six “penlight” alkaline (type LR6) batteries under this cover. |

Caution

To reduce the risks associated with hazardous voltage, which, if not avoided, may result in minor or moderate injury and/or property damage:

- Not intended to be serviced by the user. No user serviceable parts.

2.0 Preparation Before Testing

2.1 Connecting the ESD Shoe Testing Plate



Warning

To reduce the risks associated with an explosion hazard, which, if not avoided, could result in death or serious injury:

- Do not use in an explosive environment. Tester is not designed to be intrinsically safe.



Caution

To reduce the risks associated with hazardous voltage, which, if not avoided, may result in minor or moderate injury and/or property damage:

- Do not use in an outdoor and/or wet environment.

The supplied shoe testing plate and cable must be connected to test ESD protective shoes. The cable for ESD shoe testing connects to the tester and the shoe testing plate as follows:

- (1) Connect the BNC-plug end of the cable to the ESD shoe testing cable connector as shown below.
- (2) Connect the other end of the cable to the shoe testing plate using the supplied M4 screw and washer.

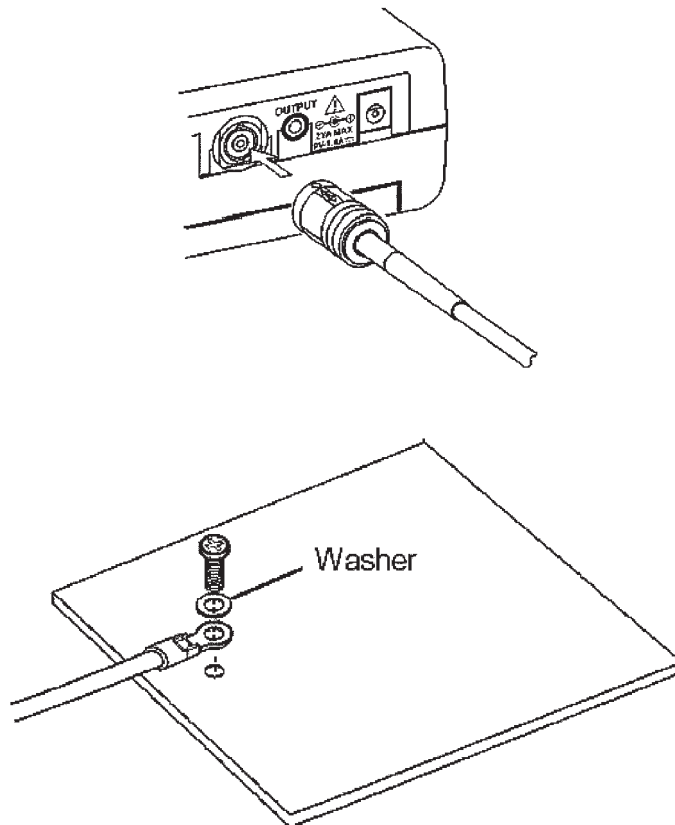

Important Note:

ESD wrist straps can be tested while the ESD shoe testing plate and cable are connected.

2.2 Threshold Resistance Settings

The test results indicated by the front panel LEDs are determined by comparison of the measured value with the threshold resistance settings (upper and lower limits).



LOW : the measured resistance is below the lower threshold
OK : the measured resistance is between the lower and upper thresholds
HIGH : the measured resistance is above the upper threshold

- (1) ESD Shoe Test Threshold Resistance Settings
The upper threshold (SHOES HIGH) and lower threshold (SHOES LOW) can be selected for shoe testing. Use tweezers to move the threshold switches.

The upper threshold (SHOES HIGH) selections are 10, 35 or 100 M Ω .
The lower threshold (SHOES LOW) selections are 100 k Ω or 1 M Ω .

- (2) ESD Wrist Strap Test Threshold Resistance Settings
The upper threshold (WRIST HIGH) can be selected for wrist strap testing. Use tweezers to move the threshold switch.

The lower threshold is fixed at 0.65 M Ω for wrist strap testing.
The upper threshold (WRIST HIGH) selections are 5, 10 or 35 M Ω .

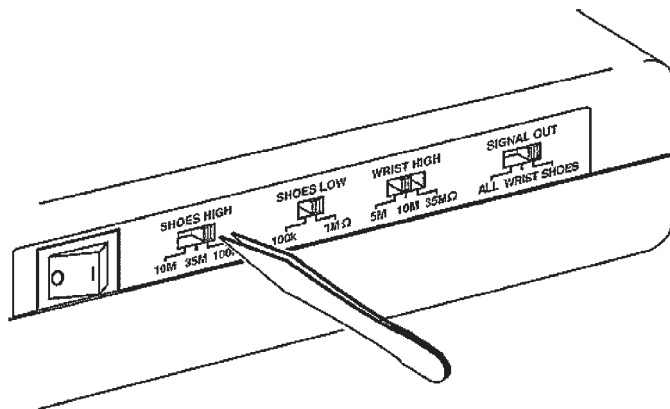

Important Notes:

- **Factory default settings are 100 M Ω for SHOES HIGH, and 10 M Ω for WRIST HIGH, and 1 M Ω for SHOES LOW.**
- **The SIGNAL OUT selection is set to SHOES. When operated as a stand-alone tester (that is, when not using the external output), this SIGNAL OUT selection should be set to either WRIST or SHOES.**

2.3 Power Preparation

2.3.1 Installing and Replacing the Batteries



Caution

To reduce the risks associated with hazardous voltage, which, if not avoided, may result in minor or moderate injury and/or property damage:

- When placing batteries, turn the power switch off and disconnect all the cables before beginning.
- Always replace battery cover before using the tester.

Important Notes:

- To avoid electric shock when replacing the batteries, turn the power switch off and disconnect the all cables before beginning. Also, after replacing the batteries, always replace the cover before using the unit.
- When replacing the batteries, do not install old batteries with new ones, and do not mix different types of batteries. Check the battery polarity carefully when inserting the batteries.
- Do not short-circuit used batteries, disassemble them, or throw them in a fire. Doing so may cause the batteries to explode.
- Keep used batteries out of the reach of children. Dispose of used batteries according to their type in the prescribed manner and in the proper location.
- Remove the batteries before storage to prevent possible corrosion caused by battery leakage if the tester will not be used for a long period of time.
- When using the AC adapter, remove the batteries from the tester to prevent corrosion due to possible electrolyte leakage.

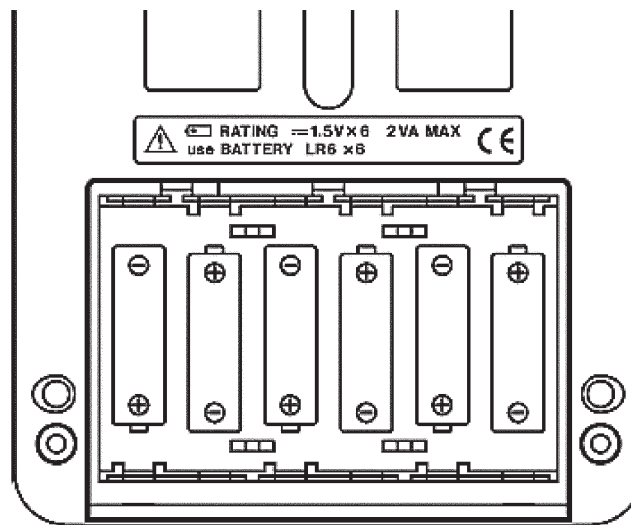

This tester can be operated from six “AA” alkaline (type LR6) batteries or the supplied AC Adapter. The AC adapter has priority, so when the batteries are installed and-the-adapter is connected, battery power is not drained.

- (1) Confirm that the power switch is turned off.
- (2) Disconnect all cables from the tester.
- (3) Remove the battery cover from the rear panel, and insert six fresh type “AA” batteries, with careful attention to the indicated polarity.
- (4) Replace the battery cover securely.

2.3.2 AC Adapter Connection



Caution

To reduce the risks associated with hazardous voltage, which, if not avoided, may result in minor or moderate injury and/or property damage:

- AC adapter must have all local required regulatory certifications.
- Do not use AC adapter and/or power cord if damaged.

This tester can be operated from six “AA” alkaline (type LR6) batteries or the supplied AC Adapter. The AC adapter has priority, so when the batteries are installed and the adapter is connected, battery power is not drained.

- (1) Confirm that the power switch is turned off.
- (2) Connect the output plug from the AC Adapter to the mating jack on the side panel.
- (3) Check to ensure that your AC mains voltage matches the voltage rating of the AC Adapter, and then plug it in.

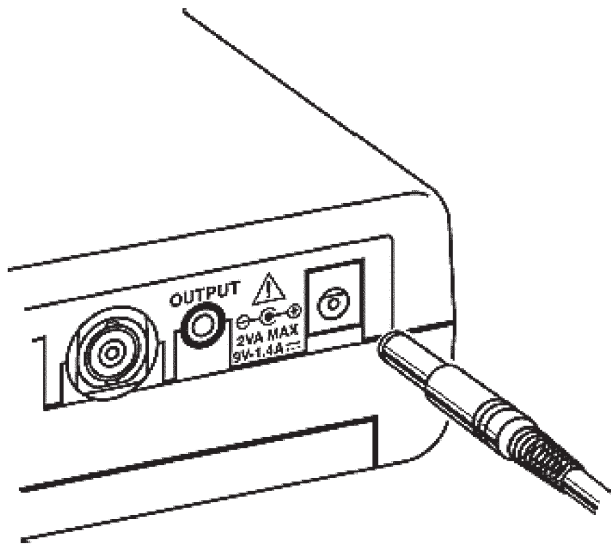

2.4 Turning Power On and Off

• Turning Power On

- (1) Set the power switch on the side panel to the on position (|).
- (2) Press a finger on the touch panel on the front of the tester to switch it on and begin a test.

• Turning Power Off

Set the power switch on the side panel to the off position (O).

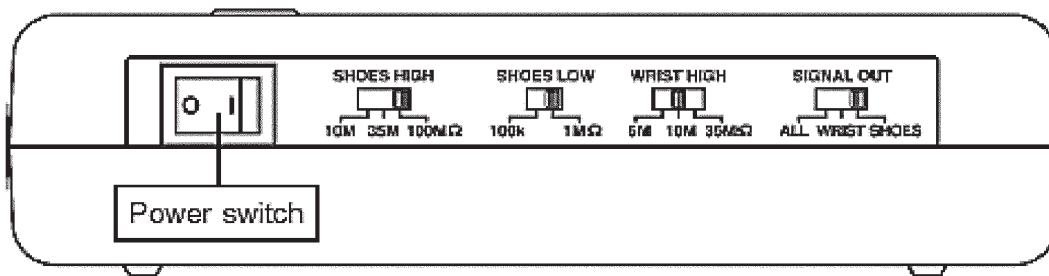

• Power Saver Function

The power saver function conserves power by automatically turning the tester off (or entering stand-by state during AC operation) ten seconds after completing a test.

This function is disabled when using RS-232C communications.

Important Note:

When operating on batteries, the power saver function minimizes battery drain, although a very small amount of current is still required by the tester. Turn the power switch off to completely disconnect the batteries.

2.5 Wall Mounting

The supplied Wall-Mount Board allows the tester to be easily mounted on the wall while still being readily removable.

As shown in the figure below, the board is affixed to the wall with three screws (either M4 machine screws or 4.1-mm-diameter wood screws). The tester is then attached to the board by aligning the back-side mounting holes over the hooks on the board.

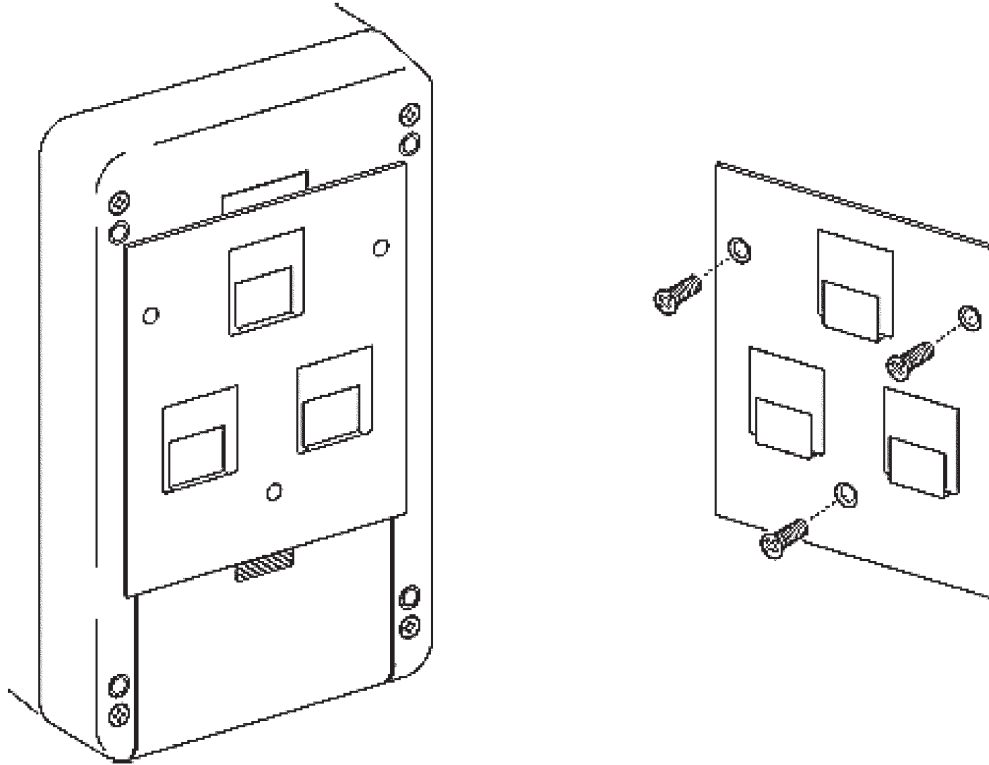

Important Note:

Screws are not included. Please use either M4 machine screws or wood screws with a nominal diameter of 4.1 mm for mounting. Either flat head or round head screws may be used.

3.0 Testing



Caution

To reduce the risks associated with electrostatic discharge (ESD), which, if not avoided, may result in property damage to electronic components or assemblies being handled.

- Perform operational verification test to ensure proper operation of the tester as required.

When used as a stand-alone tester (that is, when not using the external output), the SIGNAL OUT test result output selector switch should be set to either WRIST or SHOES.

With the SIGNAL OUT switch set to either of these positions, both ESD shoe and wrist tests can be performed.

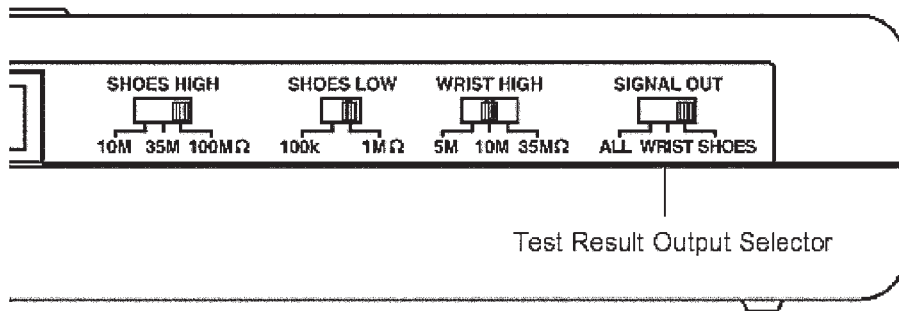

The ALL setting is described in Section 4.1, “Open Collector Output.”

Error Message	Meaning	Solution
Err.1	Finger removed from touch panel during measurement	Repeat the test
Err.2	Actual test type does not match specified test type	Check test type (location), and repeat the test
O.F.	Measured value exceeded 200.0 MΩ (Overflow)	Check test type and connections, and repeat the test

3.1 ESD Shoe Testing

This procedure tests the effectiveness of ESD protective shoes, and displays the actual measured resistance value along with the qualitative test result.

- (1) Ensure that the supplied shoe testing cable is connected between the shoe testing plate and the shoe testing connector.
Refer to Section 2.1, “Connecting the ESD Shoe Testing Plate.”
- (2) Select the required threshold resistance values.
Refer to Section 2.2, “Threshold Resistance Settings (1).”
- (3) The wrist strap must not be connected to the front panel connector during shoe testing. If it is connected, remove it.
- (4) Step on the shoe testing plate, then press the touch panel with your finger. Continue pressing the touch panel until measurement is completed (until the **MEASURE** indicator goes out).
Testing starts and the following indicators are displayed:
 - **MEASURE** and  symbol appear on the LCD.
 - The shoe LED lights yellow.

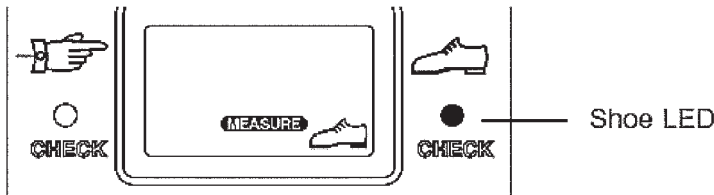

- (5) Testing finishes in about a second, and the results are displayed as follows:
 - **HOLD** and  symbol appear on the LCD.
 - The measured value appears on the LCD, and one of the result LEDs lights according to the test result --(comparison of measured value and thresholds).
 - The shoe LED lights either green or red according to the test result:
 - When the test result is OK, the LED lights green.
 - When the test result is HIGH or LOW, the LED lights red.

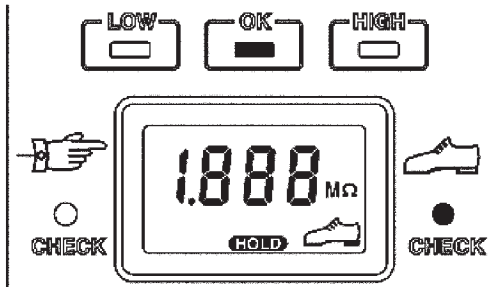

- (6) When the test is finished, the results are displayed for about ten seconds. Afterwards, if running on batteries, the power turns off. If running on the AC adapter, the power saver activates the stand-by state.

Important Notes:

- *The high end of the measurement range of the tester is 200.0 MΩ. If the measured value exceeds this limit, “O.F.” is displayed on the LCD.*
- *If the finger is removed from the touch panel during a test (while **MEASURE** appears on the LCD), or if pressure is too light on the touch panel, “Err.1” appears on the LCD. In this case, repeat the test.*
- *If a test is performed while the wrist strap cable is connected to the front panel, the wrist strap is automatically selected for measurement.*

3.2 ESD Wrist Strap Testing

Important Note: Use single-conductor wrist straps only.

This procedure tests the effectiveness of an ESD protective wrist strap, and displays the actual measured resistance value along with the qualitative test result.

- (1) Select the required threshold resistance values.
Refer to Section 2.2, “Threshold Resistance Settings (2).”
- (2) Connect the wrist strap cable to the connector on the front panel.
- (3) Press the center of the touch panel with your finger. Continue pressing the touch panel until measurement is completed (until the **MEASURE** indicator goes out).
Testing starts and the following indicators are displayed:
 - **MEASURE** and  symbol appear on the LCD.
 - The wrist strap LED lights yellow.

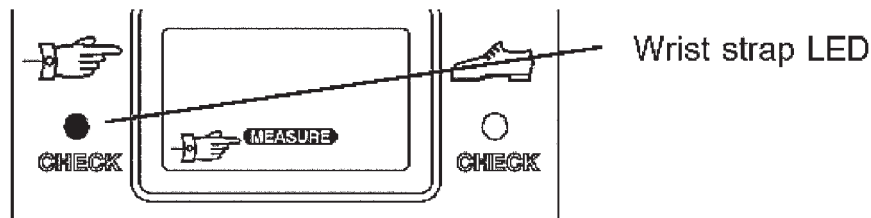

- (4) Testing finishes in about a second, and the results are displayed as follows:
 - **HOLD** and  symbol appear on the LCD.
 - The measured value appears on the LCD, and one of the result LEDs lights according to the test result --(comparison of measured value and thresholds).
 - The wrist strap LED lights either green or red according to the test result:
 - When the test result is OK, the LED lights green.
 - When the test result is HIGH or LOW, the LED lights red.

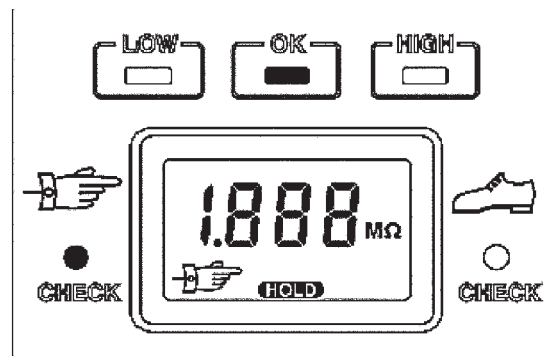

- (5) When the test is finished, the results are displayed for about ten seconds. Afterwards, if running on batteries, the power turns off. If running on the AC adapter, the power saver activates the stand-by state.

Important Notes:

- **The high end of the measurement range of the tester is 200.0 MΩ. If the measured value exceeds this limit, “O.F.” is displayed on the LCD.**
- **If the finger is removed from the touch panel during a test (while **MEASURE** appears on the LCD), or if pressure is too light on the touch panel, “Err.1” appears on the LCD. In this case, repeat the test.**
- **Wrist strap testing can be done even when the shoe testing cable and plate are connected.**

4.0 External Output Function

4.1 Open Collector Output

Important Note: Always turn the power switch off when making connections. To avoid damage to the tester, do not apply more than the rated voltage and current to the OUTPUT connector.

Test results are available at the OUTPUT connector. By providing external power, a relay or sequencer can be controlled, for example, to open and close an automatic door.

After a measurement, if the test result is OK, the transistor controlling the open-collector output will turn on for 400 ms.

The output transistor functions as a switch between the output signal and internal ground. When the test result is OK, current flows from the output terminal to the internal ground.

• Test Result Output Terminal

Mating Plug (stereo mini-phone)
Mating Plug Size
Open Collector Output Ratings

JIS C6560-1994 compatible
14 mm by 3.5 mm diameter
Absolute maximum 30 VDC, 30 mA

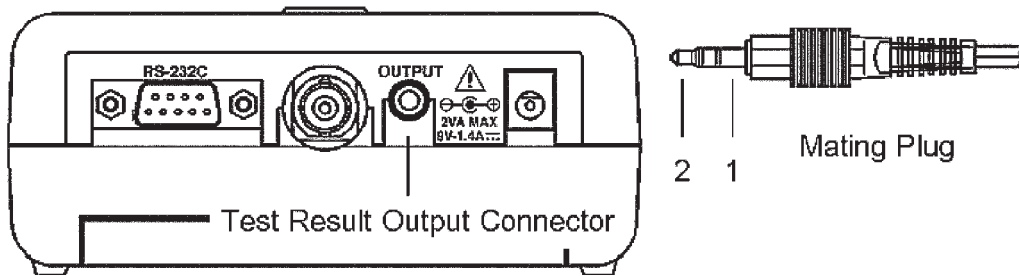

• Internal Circuit

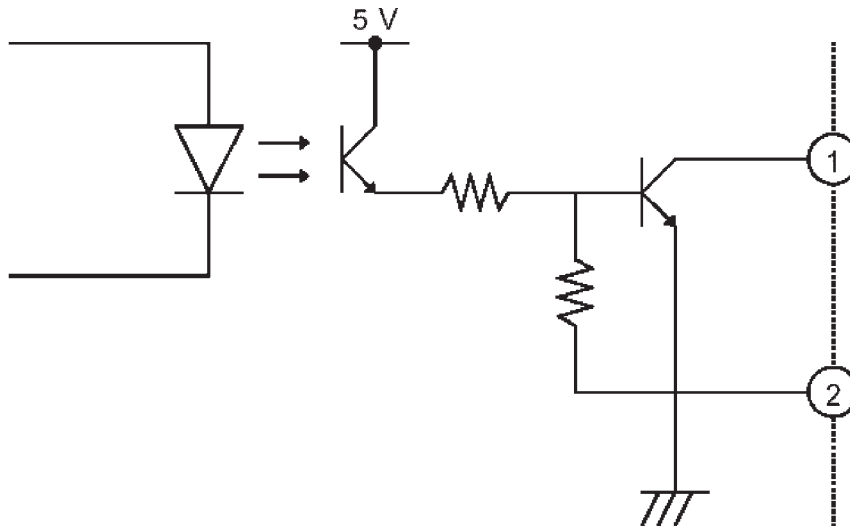

Important Note:
Mating plug not included. Please ensure that the plug used is of the type indicated above.

4.1 Open Collector Output (continued)

• Test Result Output Settings

Using tweezers, select the test result type to be provided at the OUTPUT jack using the SIGNAL OUT switch on the side of the tester.

ALL: Results of both shoe and wrist strap tests are output.

WRIST: Only wrist strap test results are output.

SHOES: Only shoe test results are output.

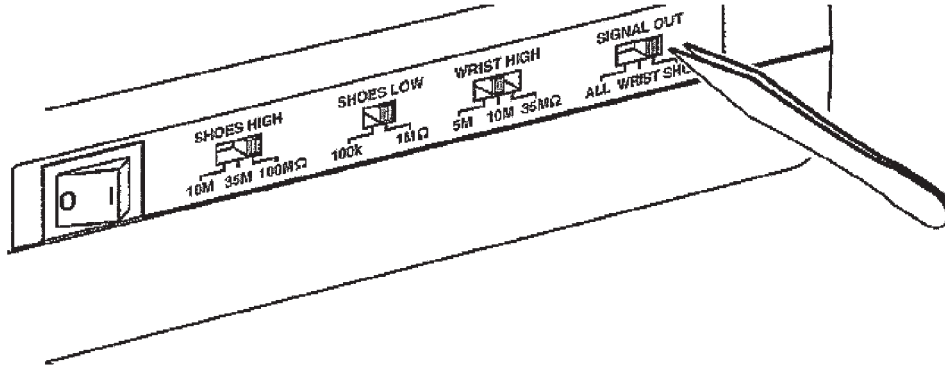

The OUTPUT terminal transistor will not turn on unless the SIGNAL OUT switch setting corresponds with the type of actual test performed, even if the result of that test is OK.

Open-Collector Output

- When the SIGNAL OUT switch is set to ALL:
The output transistor switches on when the results of the shoe and wrist strap tests are OK.
When making alternating shoe/wrist strap tests, the type of test to be conducted next is indicated by the blinking symbol on the LCD and the blinking LED.
- When the SIGNAL OUT switch is set to WRIST:
The output transistor is on when the result of a wrist strap test is OK.
- When the SIGNAL OUT switch is set to SHOES:
The output transistor is on when the result of a shoe test is OK.

Shoe and Wrist Strap (ALL) Setting

- If you attempt to test while the wrist strap LED is blinking and without having the wrist strap connected to the tester, “Err.2” appears on the LCD. In this case, connect the wrist strap cable to the front panel connector and test again.
- Conducting a wrist strap test followed immediately by a shoe test allows the shoe test to be performed while the wrist strap remains connected to the front panel when testing one shoe only.

Important Note:

Using the 3M™ software 747DLS with the 3M Tester 747 requires the following action: When testing a wrist strap and two shoes, the wrist strap ground cord must be disconnected from the 3M Tester 747 after testing the wrist strap to perform the shoes test.

- If more than ten seconds elapse between a shoe test and a wrist strap test, the automatic power-off function clears the last test results. In this case, repeat the last test.

4.2 RS-232C Communications



Caution

To reduce the risks associated with hazardous voltage, which, if not avoided, may result in minor or moderate injury and/or property damage:

- Always replace battery cover before using the tester.

Important Notes:

- Always turn the power switch off when making connections. To avoid damage to the tester, do not apply more than the rated voltage and current to the OUTPUT connector.
- To avoid damage to the unit, do not short or input voltage to the RS-232C terminal.
- When connecting the RS-232C cable, always secure with the thumb screws.
- To use the communication function, the unit must be operating with the AC adapter connected.
- In order to avoid electric shock, turn off the power to all devices before plugging in or unplugging any of the interface connectors.

Test results can be transferred to a PC by RS-232C communications. Communications can begin when the tester is operating or in stand-by state. To activate the stand-by state, place a finger on the touch panel while turning the power switch on, then wait ten seconds.

Specifications

The RS-232C settings of the tester are as follows. These settings cannot be changed, so the serial port settings on the PC must be set to match.

Transmission speed	4800 bps
Data length	8 bits
Stop bits	1 bit
Parity bit	None
Handshaking	None (no X-flow or hardware)
Delimiters	Receive: CR+LF, CR. Transmit: CR+LF
Connector	9-pin D-sub male, accepts M2.6 screws

• PC Connection

The RS-232C signal wires used are as follows (no other lines are used).



Pin	Signal	I/O	Description
2	RxD	IN	Receiving Data
3	TxD	OUT	Sending Data
5	GND	GND	Signal Ground
Other pins are not used.			

• Cable Connections

The tester connects to the PC through a crossover cable. The transmit and receive lines are crossed, and the ground lines connect together. The other lines are ignored, but hardware flow control must be disabled at the PC side.

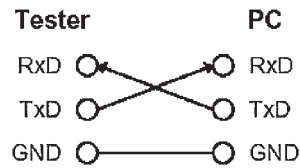

Cable wiring at tester end: cross-connected

4.3 Card Reader Technical Specifications

Serial Interface Specification:

Bit Rate - 110, 300, 1200, 2400, 4800, 9600, 19200, 38400, 57600, 115200 (selectable)

Word Length:

Data Format - 4, 5, 6, 7, 8 (selectable)

Parity Bit - Even, Odd, None, Mark, Space (selectable)

Stop Bit - 1, 1.5, 2 (selectable)

Handshaking (Flow Control) - None, Xon/Xoff, RTS/CTS, RTS/XonXoff (selectable)

Magnetic Card Reader Data:

Message Indicator

Start of Text - Single ASCII character

End of Text - Single ASCII character

Track Framing Characters

Track 1 Start - Single ASCII character

Track 1 End - Single ASCII character

Track 2 Start - Single ASCII character

Track 2 End - Single ASCII character

Track 3 Start - Single ASCII character

Track 3 End - Single ASCII character

Bar Code Reader Data:

Message Indicator

Start of Text - Single ASCII character

End of Text - Single ASCII character

Proximity Card Reader Data:

Start of Text - Two ASCII character

End of Text - CR, LF, CR/LF (selectable)

4.4 PC System Requirements

Windows™ 95, 98 2nd Edition, 2000 with Service Pack 2 and Millennium Edition, Pentium 133 MHz; 32 MB RAM; 6 MB Hard Disk Space; 800x600 True Color 32 bit Display. Single Station Operation - Requires two communication ports available (COM1 & COM2) Multiple Station Operation - Requires one PCI available slot, two is recommended for full eight-station operation.

5.0 Specifications

5.1 Measurement Section

Rated Test Terminal Voltage and Voltage Tolerance (with Test Terminals Shorted)

Shoe Test	48 VDC Voltage Tolerance: $\pm 5\%$
Wrist Strap Test	18 VDC Voltage Tolerance: $\pm 5\%$
Max. Test Current	Less than 100 μA (shoes and wrist strap)

The measurement resistance range is automatically selected from the following according to the actual measured value. The resistance range cannot be set manually.

Measurement Resistance Range (0 to 200.0 M Ω)

2-M Ω Range	Max. display value: 2.000 M Ω (0.001-M Ω resolution)
20-M Ω Range	Max. display value: 20.00 M Ω (0.01-M Ω resolution)
200-M Ω Range	Max. display value: 200.0 M Ω (0.1-M Ω resolution)

Measurement Accuracy (within 15° to 28°C , 80% rh or less, non-condensating)

Accuracy	$\pm 3\%$ rdg. ± 2 dgt. (including display tolerance)
Temp. Characteristic (0° to 15°C , 28° to 40°C)	Add $\pm 3\%$ rdg. ± 3 dgt. to above accuracy
Measurement Period	Within one second

Testing Thresholds

Shoe Test	Lower Threshold resistance: 100 k Ω or 1 M Ω Upper Threshold resistance: 10, 35 or 100 M Ω
Wrist Strap Test	Lower Threshold resistance: 0.65 M Ω Upper Threshold resistance: 5, 10 or 35 M Ω

rdg. (displayed or indicated value)

This signifies the value actually being measured, i.e., the value that is currently indicated or displayed by the measuring instrument.

dgt. (resolution)

Signifies the smallest display unit on a digital measuring instrument, i.e., the value displayed when the last digit on the digital display is “1”.

5.2 General Specifications

Ambient Operating Conditions	The unit should always be operated indoors in a range from 0°C to 40°C and 80% RH or less. Do not use the unit in direct sunlight, dusty conditions, or in the presence of corrosive gasses.
	Indoor, max. 6.562' (2000 m) height
Ambient Storage Conditions	Do not store or use the unit where it will be exposed to direct sunlight, high temperatures, high humidity or condensation. If exposed to such conditions, the unit may be damaged, the insulation may deteriorate, and the unit may no longer satisfy its specifications.
	The unit should always be stored indoors in a range from -10°C to 50°C and 85% RH or less.
Maximum Rated power	2 VA
Power Supply	"AA," LR6 alkaline battery x 6 (1.5 VDC) AC adapter. Input: 100–250 VAC; Output: 9 VDC @ 1.4 A rated load; Output plug dimensions: 4,8 mm O.D. x 1,7 mm I.D. x 9,5 mm Length Output plug polarization: center positive AC adapter must have all local required regulatory certifications
Dimensions	4.72" W X 7.72" H X 1.89" D (120 mm X 196 mm X 48 mm)
Mass	Approx. 20.5 oz (580 g) (including: ESD shoe testing cord)
Wrist Strap Banana Jack Diameter	4.20 mm
Interface	RS-232C and open collector output
External Jack	Three select qualitative testing thresholds, and one selects the test type results to be available at the OUTPUT jack
Selection Switches	Threshold resistance selection switch x 3 Test result output selection switch x 1
Accessories	AC adapter ESD shoe testing cord Wall-mounting board Instruction manual, CD ESD shoe testing plate Mounting screw for ESD shoe testing plate (w/washer) LR6 alkaline battery x 6 Warranty card
Standard Applying	EMC EN61326-1:1997+A1:1998 EN 6100-3-2:1995+A1:1998+A2:1998 EN 6100-3-3:1995 Safety EN61010-1:1993+A2:1995 Pollution degree 2 overvoltage category I (anticipated transient overvoltage 2500 V)
Regulatory Compliance	This equipment has been tested and found to comply with the limits for a Class A digital device, pursuant to Part 15 of the FCC Rules. These limits are designed to provide a reasonable protection against harmful interference when the equipment is operated in a commercial environment. This equipment generates, uses, and can radiate radio frequency energy and, if not installed and used in accordance with the instruction manual, may cause harmful interference to radio communications. Operation of this equipment in a residential area is likely to cause harmful interference in which case the user will be required to correct the interference at his own expense. This Class A digital apparatus meets all requirements of the Canadian Interference-Causing Equipment Regulations. Cet appareil numérique de la classe A respecte toutes les exigences du Règlement sur le matériel brouilleur du Canada.

6.0 Maintenance & Service

6.1 Battery Replacement Indicator



To reduce the risks associated with hazardous voltage, which, if not avoided, may result in minor or moderate injury and/or property damage:

- When replacing batteries, turn the power switch off and disconnect all the cables before beginning.
- Always replace battery cover before using the tester.

Important Notes:

- *Remove the batteries before storage to prevent possible corrosion caused by battery leakage if the tester will not be used for a long period of time.*
- *When using the AC adapter, remove the batteries from the tester to prevent corrosion due to possible electrolyte leakage.*
- *When replacing the batteries, do not install old batteries with new ones, and do not mix different types of batteries. Check the battery polarity carefully when inserting the batteries.*
- *Do not short-circuit used batteries, disassemble them, or throw them in a fire. Doing so may cause the batteries to explode.*
- *Keep used batteries out of the reach of children. Dispose of used batteries according to their type in the prescribed manner and in the proper location.*

When the battery symbol (🔋) appears on the LCD, replace the batteries. Refer to Section 2.3.1 “Installing and Replacing the Batteries.”

6.2 Error Messages

The LCD can display the following error messages:

Error Message	Meaning	Solution
Err.1	Finger removed from touch panel during measurement	Repeat the test
Err.2	Actual test type does not match specified test type	Check test type (location), and repeat the test
O.F.	Measured value exceeded 200.0 MΩ (Overflow)	Check test type and connections, and repeat the test

6.3 Before Returning the Tester for Service



Caution

To reduce the risks associated with hazardous voltage, which, if not avoided, may result in minor or moderate injury and/or property damage:

- Not intended to be serviced by the user. No user serviceable parts.

Problem	Items to check
Measurement does not start when pressing the touch panel	Are the batteries depleted? Is the AC adapter connected? (Sec. 2.3.2) Is the power switch on? (Sec. 2.4)
Abnormal measurement values	Is the shoe testing plate connected? (Sec. 2.1)
Abnormal test results	Are the threshold resistance switch selections correct? (Sec. 2.2)
Test results not available at OUTPUT terminal	Is the SIGNAL OUT switch selection correct? (Sec. 4.1)
RS-232C communication inoperable	Is the tester running on the AC adapter? (Sec. 2.3.2) Are the serial communications settings correct? (Sec. 4.2) Is a crossed cable being used for the connection? (Sec. 4.2)

6.4 Service

For repair or calibration service, contact 3M Electronic and Interconnect Solutions Division, Customer Service 1-800-328-1368.

6.5 Cleaning

Gently wipe dirt from the surface of the unit with a soft cloth moistened with a small amount of water or mild detergent.

7.0 Operational Verification Test



Caution

To reduce the risks associated with hazardous voltage, which, if not avoided, may result in minor or moderate injury and/or property damage:

- Not intended to be serviced by the user. No user serviceable parts.

To reduce the risks associated with electrostatic discharge (ESD), which, if not avoided, may result in property damage to electronic components or assemblies being handled:

- Perform operational verification test to ensure proper operation of the tester as required.

Testing Considerations

- This test procedure is used to verify that the 3M™ Shoes & Wrist Strap Tester 747 functions within the specifications as stated in Chapter 5 of this instruction manual. It is recommended that you become familiar with the operation of the tester outlined in this manual, before beginning testing.
- Environmental test conditions when performing this procedure are 59°F (15°C) to 82°F (28°C), 80% RH or less, non-condensating.
- It is recommended that this procedure be performed annually. However, if the unit is exposed to a harsh environment or has been abused in some manner, it may require performing this test procedure more frequently.

Equipment Required

- Resistance Substitution Box (RSB) - 630 KΩ to 103 MΩ (minimum range) ±1% or discrete resistors ±1%, using resistor values as indicated in the tables below.
- Lead wires - As required to connect between RSB and the 3M Shoes & Wrist Strap Tester 747.
- 3M™ 1181 Copper Foil Tape w/conductive adhesive or equivalent (4" L x 1" W recommended).
- 3M™ PA -1 Tape Wipe tool, Blue color (75-3454-4264-6) or Gold color (74-1901-9168-9) or equivalent.

Test Set-Up

Apply a strip of copper foil tape to the unit's "Touch Panel" as shown in Fig. 1, leaving a short tab for the purpose of attachment of a test lead. To prevent the copper foil tape from curling during removal of the release liner, peel the release liner from the copper foil tape. To improve electrical contact between the copper foil tape and the "Touch Panel," wipe the copper foil tape lengthwise using the "Tape Wipe" tool while applying slight pressure.

Testing Wrist Strap Ranges

Connect the reference resistor to the “Wrist Strap Connector” and the tab of the copper foil tape on the 3M™ Shoes & Wrist Strap Tester 747 as shown in Fig. 1.

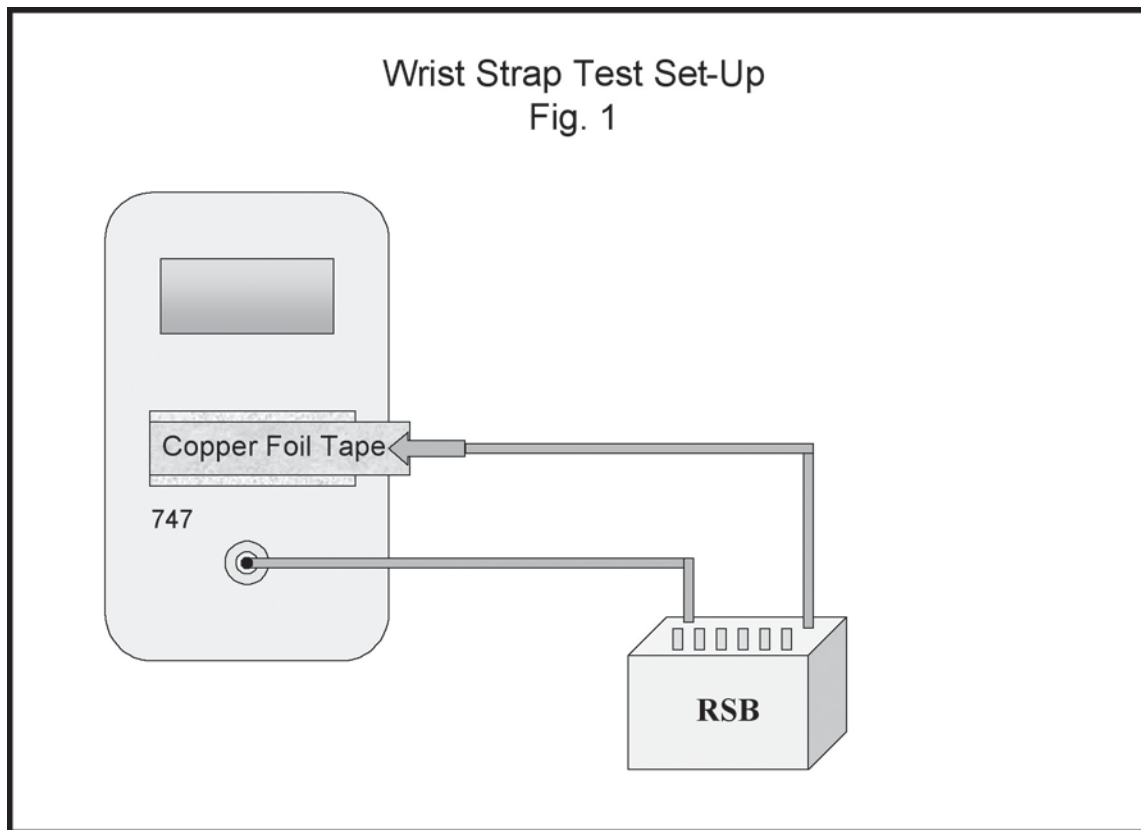

Testing Wrist Low Limit - Refer to Wrist Test Table

1. Switch on the 3M Tester 747.
2. Select 5 M Ω position on the “Wrist High” switch.
3. Select Wrist position on the “Signal Out” switch.
4. Set reference resistor to 630 K Ω .
5. Press down on the “Touch Panel” and observe LED indicators and value displayed on LCD comparing to Wrist Test Table below.
6. Set reference resistor to 670 K Ω .
7. Press down on the “Touch Panel” and observe LED indicators and value displayed on LCD comparing to Wrist Test Table below.

Testing Wrist High Limits - Refer to Wrist Test Table

8. Repeat test sequence using specified reference resistors as indicated in Wrist Test Table below for “Wrist High” 5 M Ω , 10 M Ω , & 35 M Ω positions.

Wrist Test Table

Reference Resistor	Wrist High Range Switch Setting	Wrist Strap Check LED Indicator	Test Result LED Indicator	LCD Display
<u>Low Limit*</u> $\leq 630 \text{ K}\Omega$ $\geq 670 \text{ K}\Omega$	5 M Ω	Red Green	Low OK	$\pm 3\%$, ± 2 dgt.**
<u>High Limit</u> $\leq 4.8 \text{ M}\Omega$ $\geq 5.2 \text{ M}\Omega$	5 M Ω	Green Red	OK High	$\pm 3\%$, ± 2 dgt.**
<u>High Limit</u> $\leq 9.7 \text{ M}\Omega$ $\geq 10.3 \text{ M}\Omega$	10 M Ω	Green Red	OK High	$\pm 3\%$, ± 2 dgt.**
<u>High Limit</u> $\leq 33.9 \text{ M}\Omega$ $\geq 36.1 \text{ M}\Omega$	35 M Ω	Green Red	OK High	$\pm 3\%$, ± 2 dgt.**

*Low limit value (650 K Ω) for wrist straps is set internally and cannot be adjusted.

**dgt. (resolution) - Signifies the smallest display unit on a digital measuring instrument, ie., the value displayed when the last digit on the digital display is "1".

Testing Shoe Ranges

Connect the reference resistor to the “Shoe Plate Cable” and the tab of the copper foil tape on the 3M™ Shoes & Wrist Strap Tester 747 as shown in the Fig. 2.

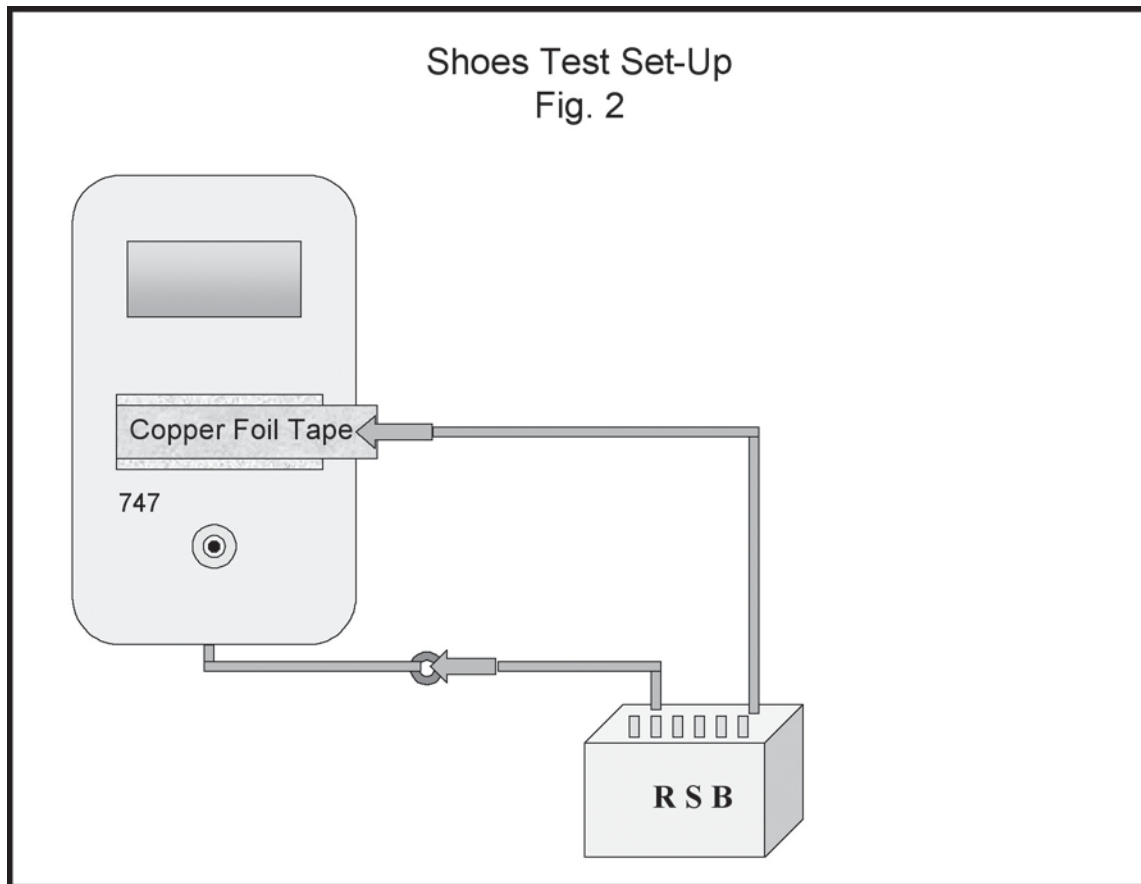

Testing Shoes Low Limits - Refer to Shoes Test Table

1. Select 10 M Ω position on the “Shoes High” switch.
2. Select 100 K Ω position on the “Shoes Low” switch.
3. Select Shoes position on the “Signal Out” switch.
4. Set reference resistor to 97 K Ω .
5. Press down on the “Touch Panel” and observe LED indicators and value displayed on LCD comparing to Shoes Test Table below.
6. Set reference resistor to 103 K Ω .
7. Press down on the “Touch Panel” and observe LED indicators and value displayed on LCD comparing to Shoes Test Table below.
8. Select 1 M Ω position on the “Shoes Low” switch.
9. Set reference resistor to 970 K Ω .
10. Press down on the “Touch Panel” and observe LED indicators and value displayed on LCD comparing to Shoes Test Table below.
11. Set reference resistor to 1.03 M Ω .
12. Press down on the “Touch Panel” and observe LED indicators and value displayed on LCD comparing to Shoes Test Table on the following page.

Testing Shoes High Limits - Refer to Shoes Test Table

13. Repeat test sequence using specified reference resistors as indicated in Shoes Test Table below for 10 MΩ, 35 MΩ & 100MΩ positions.

Shoes Test Table

Reference Resistor	Shoes High Range Switch Setting	Shoes Low Range Switch Setting	Shoe Check LED Indicator	Test Result LED Indicator	LCD Display
<u>Low Limit</u> ≤97 KΩ ≥103 KΩ	10 MΩ	100 KΩ	Red Green	Low OK	±3%, ±2 dgt.*
<u>Low Limit</u> ≤970 KΩ ≥1.03 MΩ		1 MΩ	Red Green	Low OK	±3%, ±2 dgt.*
<u>High Limit</u> ≤9.7 MΩ ≥10.3 MΩ	10 MΩ	1 MΩ	Green Red	OK High	±3%, ±2 dgt.*
<u>High Limit</u> ≤33.9 MΩ ≥36.1 MΩ	35 MΩ	1 MΩ	Green Red	OK High	±3%, ±2 dgt.*
<u>High Limit</u> ≤97 MΩ ≥103 MΩ	100 MΩ	1 MΩ	Green Red	OK High	±3%, ±2 dgt.*

*dgt. (resolution) - Signifies the smallest display unit on a digital measuring instrument, ie., the value displayed when the last digit on the digital display is “1”.

3M is a trademark of 3M Company.

Windows is a trademark of Microsoft Corporation.

All other trademarks are the properties of their respective owners.

IMPORTANT NOTICE

All statements, technical information, and recommendations related to 3M's products are based on information believed to be reliable, but the accuracy or completeness is not guaranteed. Before using this product, you must evaluate it and determine if it is suitable for your intended application. You assume all risks and liability associated with such use. Any statements related to the product which are not contained in 3M's current publications, or any contrary statements contained on your purchase order shall have no force or effect unless expressly agreed upon, in writing, by an authorized officer of 3M.

Warranty; Limited Remedy; Limited Liability. This product will be free from defects in material and manufacture for a period of one (1) year from the time of purchase. **3M MAKES NO OTHER WARRANTIES INCLUDING, BUT NOT LIMITED TO, ANY IMPLIED WARRANTY OF MERCHANTABILITY OR FITNESS FOR A PARTICULAR PURPOSE.** If this product is defective within the warranty period stated above, your exclusive remedy shall be, at 3M's option, to replace or repair the 3M product or refund the purchase price of the 3M product. **Except where prohibited by law, 3M will not be liable for any indirect, special, incidental or consequential loss or damage arising from this 3M product, regardless of the legal theory asserted.**